

REVISIONS		
REV.	DATE	CO#
1	9/27/2006	25287
2	12/27/2006	25840

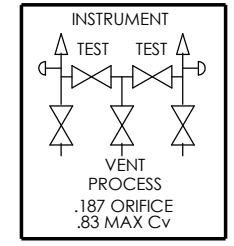
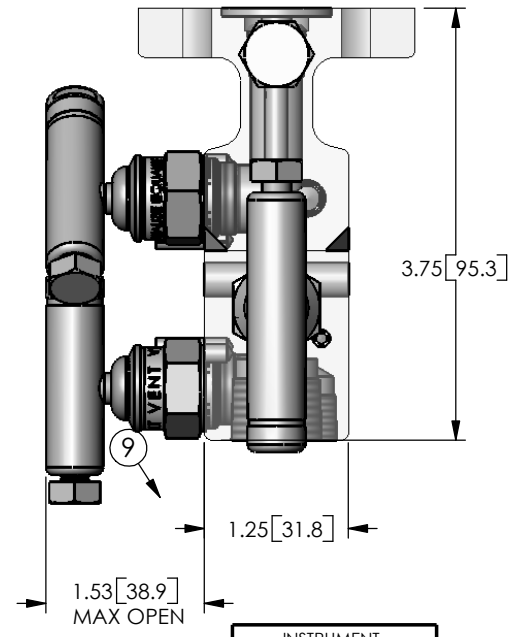
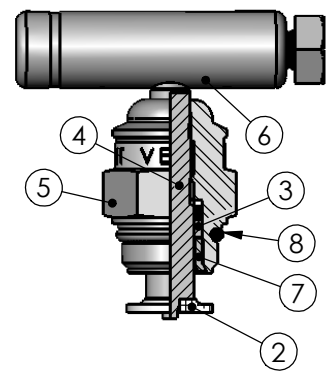
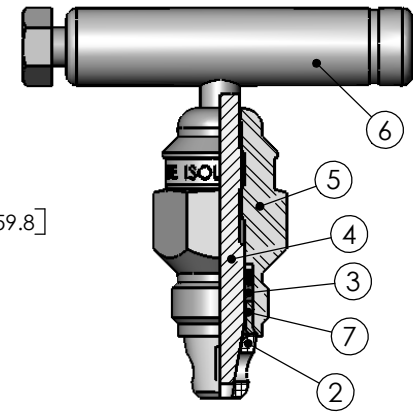
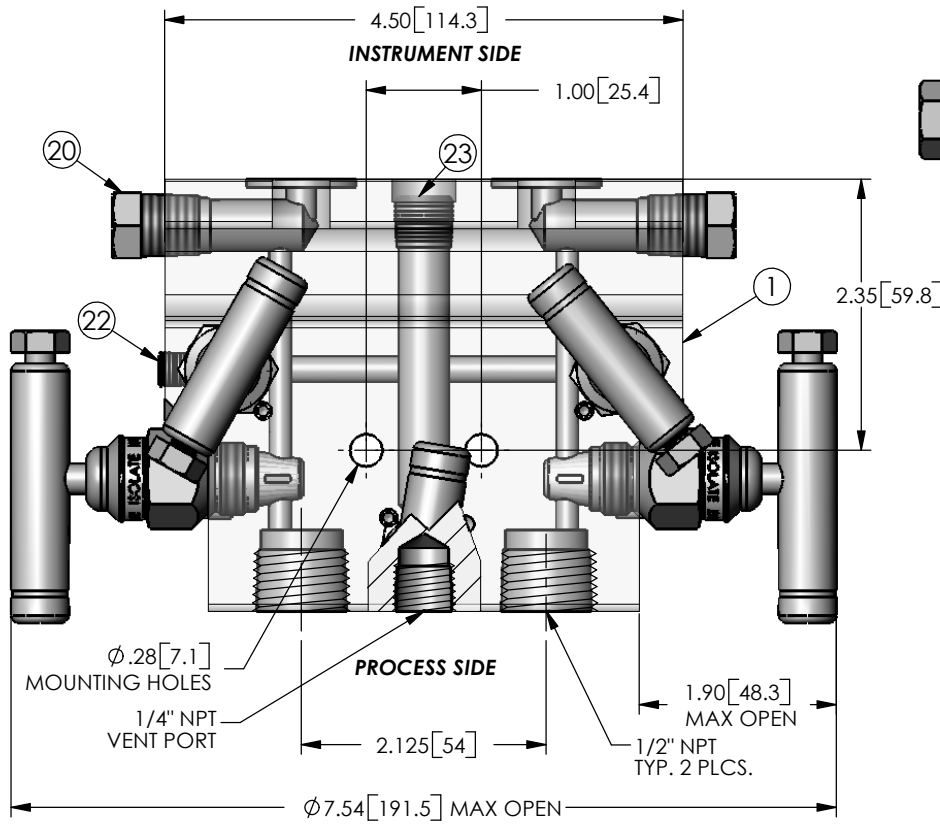

PRODUCT PART NUMBER		M-675CDT	M-675SDT		
NO.	DESCRIPTION	6,000 PSI @ 200 °F	6,000 PSI @ 200 °F	QTY.	
1	MANIFOLD BODY	(C) <AZ>ASTM A108-1215	(S) ASTM A479-316	1	
2	SOFT SEAT	(D) DELRIN	(D) DELRIN	5	
3	STEM SEAL	(T) TEFLON PRESSURE CORE	(T) TEFLON PRESSURE CORE	5	
4	STEM	ASTM A479-316	ASTM A479-316	5	
5	BONNET	<AZ> ASTM A108-1215	ASTM A479-316	5	
6	HANDLE ASSEMBLY	<AZ>ASTM A108-1215	300 SERIES S.S.	5	
7	SEAL RETAINER	ASTM A479-316	ASTM A479-316	5	
8	O-RING	VITON	VITON	3	
9	ROLL PIN	300 SERIES SS	300 SERIES S.S.	5	
10	1/4" NPT HEX HD. PLUG	<AZ>ASTM A108-1215	300 SERIES S.S.	2	
11	1/16" SOCKET HD. PLUG	<AZ>ASTM 1018-1215	300 SERIES S.S.	1	
12	1/4 NPT ALLEN HEAD P. PLUG	<AZ>ASTM A108-1215	300 SERIES S.S.	1	

NOTES

- DIMENSIONS IN [] ARE IN MILLIMETERS.
- APPROX. WEIGHT X.X lbs. (X.X kg.)
- <AZ> INDICATES ALKALINE ZINC PLATED WITH DICHROMATE DIP.
- <PO> INDICATES PHOSPHATE AND OIL.
- <P0> AISI 1018 C.S. IS USED WHEN WELDED BODY CONNECTION ARE SPECIFIED.
- 316 SS MANIFOLD/VALVE MEETS REQUIREMENTS OF NACE MR0175 (LATEST REV.) UP TO 140 °F

PGI RESERVES THE RIGHT TO CHANGE THE DESIGN, DIMENSIONS OR MATERIAL CONTENT OF OUR PRODUCTS WITHOUT PRIOR NOTIFICATION.

PGI International

16101 VALLEN DRIVE (713) 466-0056 or 1-800-231-0233
 HOUSTON, TX. 77041 FAX: (713) 744-9892

WIDE PATTERN PIPE X FLANGE 5 VALVE MANIFOLD

APP'D	DRAWING NO. & REVISION
SCALE NONE	M-675XDT r02

PGI EXTERNAL DOCUMENT
GENERAL PRODUCT DESCRIPTION