

## JBOX

## JUNCTION BOXES FOR WEIGHING SYSTEMS

Junction boxes designed to connect several load-cells in parallel to the same reading electronics with possibility of corner adjustment.

JBOX-AJBx



### Features

- o 4 or 6 inputs
- o Connexion in 4 or 6 wires
- o Cabling of load-cells and electronics by screw terminals
- o Waterproof

### Applications

- o Legal for trade or industrial weighing
- o Scales and balances

### Functions

- Easy to install
- Robust
- JBOX-4 : Low cost
- JBOX-AJB : Possibility of corner adjustment
- JBOX-AJB : Protection against electrical surge

Specifications	JBOX-4	JBOX-AJB-4	JBOX-AJB-6	
Qty of load-cells max.	4	4	6	-
Corner adjustment	No	Yes	Yes	-
IP Rating	IP66	IP67	IP67	-
Material	Polycarbonate	Stainless steel	Stainless steel	-
Service temperature range	-10...+40	-10...+40	-10...+40	C
Storage temperature range	-30...+70	-30...+70	-30...+70	C
Qty of cable gland	5	5	7	-

F.S.: full scale - Specifications subject to change without notice



# JUNCTION BOX

model JBOX-4 Polycarbonate enclosure

for 4 load cells

Protection IP66

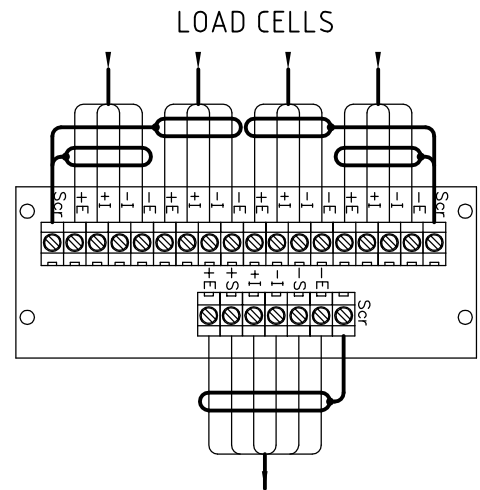
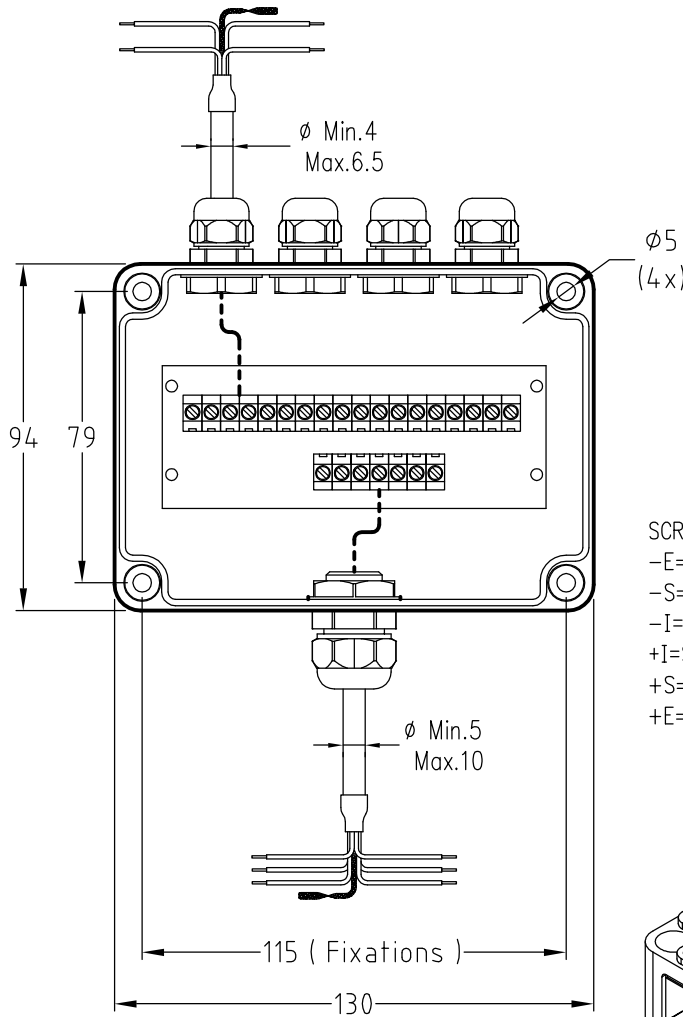
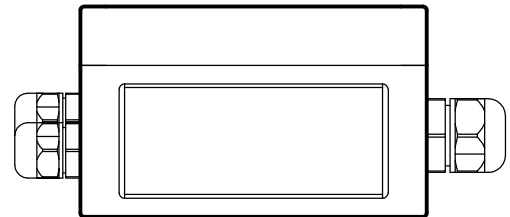
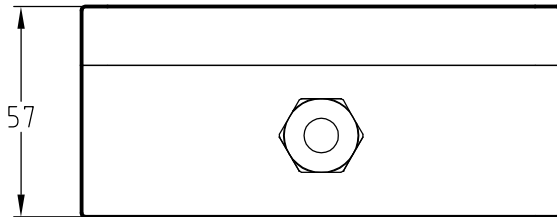

- SCR=CABLE SCREEN
- E=Exc.- (YELLOW)
- S=Sense - (GREY)
- I=Sig.- (WHITE)
- +I=Sig.+ (GREEN)
- +S=Sense + (PINK)
- +E=Exc.+ (BROWN)

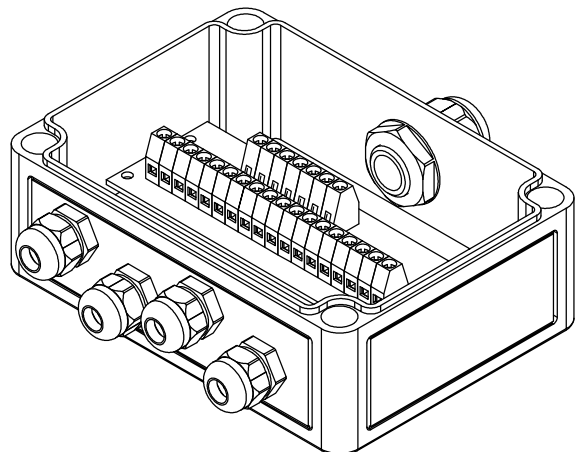



www.sensy.com

# JUNCTION BOX

**model JBOX AJB-4** for 4 Load cells

**model JBOX AJB-6** for 6 Load cells

Stainless steel junction box , IP 67

Trimming : by resistor(s) or potentiometer (0-10R)

Surge protection : 90 V clamp. Withstands up to 20 kV  
and up to 10 kA

EMI/RFI compliant to EN 45501 standard compatibility (EMC)

