

TURCK

Industrial
Automation

**BL20 –
USER MANUAL**

**MULTIPROTOCOL
GATEWAY
FOR ETHERNET
BL20-E-GW-EN**

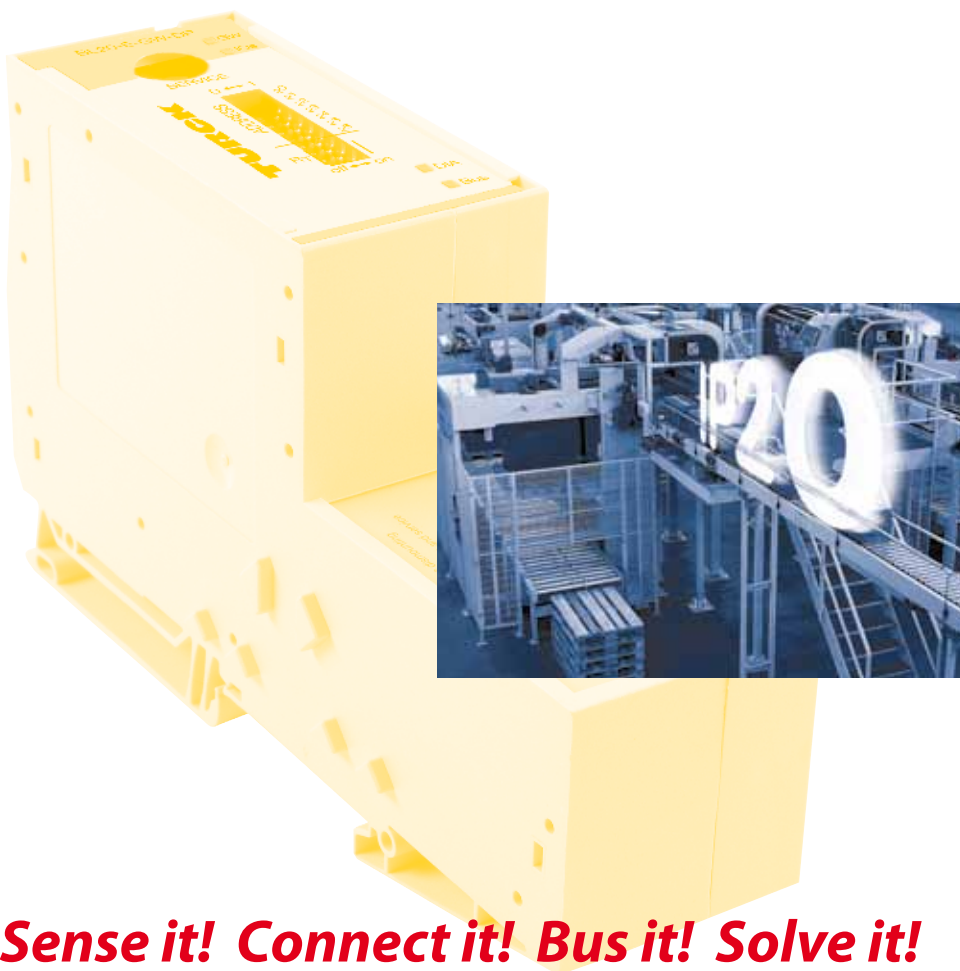

Sense it! Connect it! Bus it! Solve it!

All brand and product names are trademarks or registered trade marks of the owner concerned.

Edition 07/2013

© Hans Turck GmbH, Muelheim an der Ruhr

All rights reserved, including those of the translation.

No part of this manual may be reproduced in any form (printed, photocopy, microfilm or any other process) or processed, duplicated or distributed by means of electronic systems without written permission of Hans Turck GmbH & Co. KG, Muelheim an der Ruhr.

Subject to alterations without notice

Table of Contents

1	About this manual	
1.1	Documentation concept	1-2
1.1.1	Additional documentation	1-2
1.2	Description of symbols used	1-3
1.3	General	1-4
1.3.1	Prescribed use	1-4
1.3.2	Notes concerning planning/ installation of this product	1-4
1.4	List of revisions	1-5
2	BL20-philosophy	
2.1	The basic concept	2-2
2.1.1	Flexibility	2-2
2.1.2	Compactness	2-2
2.1.3	Easy to handle	2-2
2.2	BL20 components	2-3
2.2.1	Gateways	2-3
2.2.2	Power distribution modules	2-4
2.2.3	Electronics modules (standard product line)	2-5
2.2.4	ECO electronics modules	2-6
2.2.5	Base modules	2-7
2.2.6	End plate	2-8
2.2.7	End bracket	2-8
2.2.8	Jumpers	2-9
2.2.9	Marking material	2-9
2.2.10	Shield connection gateway	2-10
3	Properties: gateway and I/O-modules	
3.1	Function of the gateway	3-3
3.1.1	Version overview	3-3
3.2	Supported I/O-modules	3-4
3.3	Technical data	3-6
3.3.1	Top view BL20-E-GW-EN (< VN 03-00)	3-6
3.3.2	Top view BL20-E-GW-EN (≥ VN 03-00)	3-7
3.3.3	Block diagram	3-8
3.3.4	General technical data of a station	3-9
3.3.5	Technical data for the push-in tension clamp terminals	3-11
3.3.6	LED-displays	3-12
3.4	Connection options at the gateway	3-14
3.4.1	Power supply	3-14
3.4.2	Field bus connection via Ethernet-switch	3-14
3.4.3	Service interface	3-14
3.5	Address assignment	3-15
3.5.1	Default setting of the gateway	3-15
3.5.2	Function of DIP-switches	3-16

3.5.3	Resetting the IP-address, switch position "RESTORE"	3-17
3.5.4	Address setting via DIP-switches (2 ⁰ to 2 ⁷)	3-18
3.5.5	Address setting via the mode DHCP	3-19
3.5.6	Address setting via the mode BootP	3-20
3.5.7	Address setting via the mode PGM	3-21
3.5.8	Address setting via the mode PGM-DHCP (universal mode)	3-22
3.5.9	F_Reset (Reset to factory setting)	3-22
3.5.10	Addressing via I/O-ASSISTANT 3 (FDT/DTM)	3-23
3.5.11	Addressing via Web server (Version ≥ VN 03-00)	3-26
3.6	Synchronization of the station configuration	3-27
3.6.1	DIP-switch CFG	3-27
3.7	Web server - remote access/configuration (Version ≥ VN 03-00)	3-28
3.7.1	IP address	3-28
3.7.2	Access rights	3-28
3.7.3	Login / password	3-29
3.7.4	Network Configuration	3-29
3.7.5	Gateway Configuration	3-30
3.7.6	Station Diagnostics	3-30
3.7.7	Ethernet Statistics	3-30
3.7.8	Links	3-30
3.7.9	Change Admin Password	3-31
3.8	Status and Control Word of the BL20-stations	3-32
3.8.1	Status Word	3-32
3.8.2	Control Word	3-32
3.9	Parameters of the I/O-modules	3-33
3.9.1	Digital input modules	3-33
3.9.2	Analog input modules	3-33
3.9.3	Analog output modules	3-42
3.9.4	Technology modules	3-47
3.10	Diagnostic messages of the modules	3-56
3.10.1	Power distribution modules	3-56
3.10.2	Digital input modules	3-57
3.10.3	Analog input modules	3-57
3.10.4	Digital output modules	3-60
3.10.5	Analog output modules	3-62
3.10.6	Technology modules	3-63
4	Implementation of EtherNet/IP™	4-2
4.1	Diagnostic messages via the process data	4-2
4.1.1	Summarized Diagnostics	4-2
4.1.2	Scheduled Diagnostics	4-2
4.2	Classes and Instances of the EtherNet/IP™-stations	4-3
4.2.1	EtherNet/IP™ Standard Classes	4-3
4.2.2	Identity Object (0x01)	4-4
4.2.3	Assembly Object (0x04)	4-6
4.2.4	Connection Manager Object (0x06)	4-9
4.2.5	TCP/IP Interface Object (0xF5)	4-10
4.2.6	Ethernet Link Object (0xF6)	4-14

4.3	VSC-Vendor Specific Classes	4-16
4.3.1	Class Instance of the VSCs	4-16
4.3.2	Gateway Class (VSC 100, 64h)	4-17
4.3.3	Process Data Class (VSC102, 66h)	4-20
4.3.4	Miscellaneous Parameters Class (VSC 126)	4-22
5	Application example: BL20-E-GW-EN with EtherNet/IP™ (Allen Bradley)	
5.1	General	5-2
5.1.1	Used hard-/ software.....	5-2
5.2	Network configuration	5-3
5.2.1	Configuration of the network in "RS Logix 5000"	5-3
5.2.2	Downloading the I/O configuration	5-7
5.3	I/O data mapping	5-9
5.4	Process data access	5-11
5.4.1	Setting outputs	5-11
5.4.2	Example program.....	5-12
6	Implementation of Modbus TCP	
6.1	Common Modbus description	6-2
6.1.1	Protocol description	6-3
6.1.2	Data model	6-4
6.2	Implemented Modbus functions	6-6
6.3	Modbus registers	6-7
6.3.1	Structure of the packed in-/ output process data	6-12
6.3.2	Register 0x100C: Gateway status.....	6-16
6.3.3	Register 0x1130h: Modbus-Connection-Mode	6-17
6.3.4	Register 0x1131: Modbus-Connection-Timeout.....	6-17
6.3.5	Register 0x113C and 0x113D: Restore Modbus-connection parameters	6-17
6.3.6	Register 0x113E and 0x113F: „Save Modbus-Connection-Parameters“	6-18
6.3.7	Register 0x1140: Disable protocol.....	6-18
6.3.8	Register 0x1141: Active protocol.....	6-18
6.3.9	Register 0x2000 bis 0x207F: The Service-Object	6-19
6.4	Bit areas: mapping of input-discrete- and coil-areas	6-22
6.5	Error behavior of outputs (watchdog)	6-23
7	Application example: BL20-E-GW-EN for Modbus TCP (CoDeSys Win V3)	
7.1	Used hard-/ software	7-2
7.1.1	Hardware	7-2
7.1.2	Software.....	7-2
7.2	Network configuration	7-3
7.3	Programming with CoDeSys	7-4
7.3.1	Predefined feature sets	7-4
7.3.2	Creating a new project	7-5
7.3.3	Defining the communication settings.....	7-7
7.3.4	Adding the Ethernet Adapter	7-9

7.3.5	Adding the Modbus master	7-10
7.3.6	Adding a Modbus TCP slave	7-11
7.3.7	Programming (example program)	7-13
7.3.8	CoDeSys: Global variables	7-14
7.3.9	Modbus channels.....	7-15
7.3.10	Building, login and start	7-26
7.3.11	Reading out the process data	7-28
7.3.12	Diagnosis evaluation	7-29
8	Implementation of PROFINET®	
8.1	Address assignment	8-2
8.2	GSDML-file.....	8-3
8.3	Default-values	8-3
8.4	Diagnosis in PROFINET®	8-4
8.4.1	Gateway Error codes	8-4
8.4.2	Channel -specific error codes of the I/O-modules	8-5
8.5	Parameterization	8-10
8.5.1	Gateway parameters.....	8-10
8.5.2	I/O-module-parameters	8-13
8.5.3	Parameter "module parameterization"	8-13
8.6	Description of user data for acyclic services.....	8-14
8.6.1	Description of the acyclic gateway user data	8-14
8.6.2	Description of the acyclic module user data	8-15
9	Application example: BL20-E-GW-EN with PROFINET® (S7)	
9.1	Application example	9-2
9.1.1	General	9-2
9.1.2	Example network.....	9-2
9.1.3	New project in the Simatic Manager	9-3
9.1.4	Setting the PG/PC-interface.....	9-3
9.1.5	Installation of the GSDML-files.....	9-4
9.1.6	Adding PROFINET®-network nodes.....	9-8
9.1.7	Configuring the BL20-station	9-11
9.1.8	Scanning the network for PROFINET® nodes.....	9-12
9.1.9	PROFINET® neighborhood detection via LLDP	9-14
9.1.10	Online topology detection	9-17
9.2	Diagnostics with Step 7	9-18
9.2.1	Diagnostic messages in the hardware configuration	9-18
9.2.2	Diagnostic telegram with error code	9-19
10	Guidelines for station planning	
10.1	Module arrangement.....	10-2
10.1.1	Random module arrangement	10-2
10.1.2	Complete planning	10-2
10.1.3	Maximum system extension	10-3
10.2	Power supply	10-6
10.2.1	Power supply to the gateway.....	10-6

10.2.2	Module bus refreshing (BL20-BR-24VDC-D)	10-6
10.2.3	Creating potential groups.....	10-7
10.2.4	C-rail (cross connection)	10-7
10.2.5	Direct wiring of relay modules	10-9
10.3	Protecting the service interface on the gateway	10-10
10.4	Plugging and pulling electronics modules.....	10-10
10.5	Extending an existing station.....	10-10
10.6	Firmware download	10-11
11	Guidelines for Electrical Installation	
11.1	General notes.....	11-2
11.1.1	General.....	11-2
11.1.2	Cable routing	11-2
11.1.3	Lightning protection.....	11-3
11.1.4	Transmission media.....	11-3
11.2	Potential relationships.....	11-4
11.2.1	General.....	11-4
11.3	Electromagnetic compatibility(EMC	11-5
11.3.1	Ensuring electromagnetic compatibility	11-5
11.3.2	Grounding of inactive metal components.....	11-5
11.3.3	PE connection.....	11-5
11.3.4	Earth-free operation	11-5
11.3.5	Mounting rails.....	11-6
11.4	Shielding of cables	11-7
11.5	Potential compensation.....	11-8
11.5.1	Switching inductive loads	11-8
11.5.2	Protection against Electrostatic Discharge (ESD)	11-8
12	BL20-Approvals for Zone 2/ Division 2	
13	Appendix	
13.1	Data image of the technology modules	13-2
13.1.1	1RS232/ 1RS485-module	13-2
13.1.2	SSI module	13-6
13.1.3	SWIRE-module.....	13-13
13.1.4	Encoder/PWM-moduleBL20-E-2CNT-2PWM	13-15
13.1.5	RFID-moule BL20-2RFID-S/ -A.....	13-15
13.2	Changing the IP address of a PC/ network interface card	13-16
13.2.1	Changing the IP address in Windows	13-16
13.2.2	Changing the IP address via I/O-ASSISTANT V3	13-18
13.3	Deactivating/ adapting the firewall in Windows	13-19
13.4	Addressing via DHCP.....	13-22
13.5	Ident codes the BL20-modules	13-24
14	Glossary	

15 Index

1 About this manual

1.1	Documentation concept	1-2
1.1.1	Additional documentation.....	1-2
1.2	Description of symbols used	1-3
1.3	General	1-4
1.3.1	Prescribed use.....	1-4
1.3.2	Notes concerning planning/ installation of this product.....	1-4
1.4	List of revisions	1-5

1.1 Documentation concept

This manual contains all information about the gateways BL20-E-GW-EN of the product line BL20 .

- Version < VN 03-00: gateway for Modbus TCP
- Version ≥ VN 03-00: multiprotocol-gateway for Modbus TCP, EtherNet/IP™, PROFINET®

In addition to a short BL20-system description and the protocol-independent properties of the gateway and if necessary of the I/O-modules (technical properties, diagnostics, parameters, etc.), the following chapters contain two protocol-dependent chapters respectively.

The protocol-dependent chapters contain on the one hand the protocol-specific gateway-properties and on the other hand an application example for the respective Ethernet-protocol, describing the device's connection to automation devices.

- EtherNet/IP™
 - [chapter 4, Implementation of EtherNet/IP™](#)
 - [chapter 5, Application example: BL20-E-GW-EN with EtherNet/IP™ \(Allen Bradley\)](#)
- Modbus TCP
 - [chapter 6, Implementation of Modbus TCP](#)
 - [chapter 7, Application example: BL20-E-GW-EN for Modbus TCP \(CoDeSys Win V3\)](#)
- PROFINET®
 - [chapter 8, Implementation of PROFINET®](#)
 - [chapter 9, Application example: BL20-E-GW-EN with PROFINET® \(S7\)](#)

Additionally, the manual contain protocol-independent guideline for station configuration, the electrical installation, etc..

1.1.1 Additional documentation

- BL20 I/O-modules (TURCK-documentation no.: German [D300716](#); English [D300717](#)).

The bus-independent I/O-modules of the BL20-system as well as all bus independent information as mounting, labeling etc. are described in a separate manual.

In addition to that, the manual contains a short description of the I/O-ASSISTANT, the project planning and configuration software tool for TURCK I/O-systems-

- BL20-E-2CNT-2PWM, (TURCK-documentation no.: German [D301223](#); English [D301224](#))

1.2 Description of symbols used



Warning

This sign can be found next to all notes that indicate a source of hazards. This can refer to danger to personnel or damage to the system (hardware and software) and to the facility. This sign means for the operator: work with extreme caution.



Attention

This sign can be found next to all notes that indicate a potential hazard. This can refer to possible danger to personnel and damages to the system (hardware and software) and to the facility.



Note

This sign can be found next to all general notes that supply important information about one or more operating steps. These specific notes are intended to make operation easier and avoid unnecessary work due to incorrect operation.

1.3 General



Attention

Please read this section carefully. Safety aspects cannot be left to chance when dealing with electrical equipment.

This manual includes all information necessary for the prescribed use of the BL20-E-GW-EN. It has been specially conceived for personnel with the necessary qualifications.

1.3.1 Prescribed use

Appropriate transport, storage, deployment and mounting as well as careful operating and thorough maintenance guarantee the trouble-free and safe operation of these devices.



Warning

The devices described in this manual must be used only in applications prescribed in this manual or in the respective technical descriptions, and only with certified components and devices from third party manufacturers.

1.3.2 Notes concerning planning/ installation of this product



Warning

All respective safety measures and accident protection guidelines must be considered carefully and without exception.

1.4 List of revisions

In comparison to the previous manual edition, the following changes/ revisions have been made.

*Tabelle 1-1:
List of revisions*

Chapter	Topic	new	changed
Chap. 3	Version overview (page 3-3)	X	
	Top view BL20-E-GW-EN (< VN 03-00), page 3-6	X	
	Top view BL20-E-GW-EN (≥ VN 03-00), page 3-7	X	
	LED-displays (page 3-12)		X
	Function of DIP-switches (page 3-16)		X
	Addressing via IP Address Tool (page 3-27)	X	
Chap. 7	Diagnosis evaluation (page 7-29)	X	



Note

The publication of this manual renders all previous editions invalid.

About this manual

2 BL20-philosophy

2.1	The basic concept	2-2
2.1.1	Flexibility	2-2
2.1.2	Compactness	2-2
2.1.3	Easy to handle	2-2
2.2	BL20 components	2-3
2.2.1	Gateways	2-3
	– ECO-gateways	2-3
	– Gateways with integrated power supply	2-4
	– Gateways without integrated power supply	2-4
2.2.2	Power distribution modules.....	2-4
2.2.3	Electronics modules (standard product line)	2-5
2.2.4	ECO electronics modules.....	2-6
2.2.5	Base modules.....	2-7
2.2.6	End plate.....	2-8
2.2.7	End bracket.....	2-8
2.2.8	Jumpers	2-9
2.2.9	Marking material	2-9
2.2.10	Shield connection gateway.....	2-10

2.1 The basic concept

BL20 is a modular I/O system for use in industrial automation. It connects the sensors and actuators in the field with the higher-level master.

BL20 offers modules for practically all applications:

- Digital input and output modules
- Analog input and output modules
- Technology modules (counters, RS232 interface...)

A complete BL20 station counts as **one** station on the bus and therefore occupies **one** fieldbus address in any given fieldbus structure.

A BL20 station consists of a gateway, power distribution modules and I/O modules.

The connection to the relevant fieldbus is made via the bus-specific gateway, which is responsible for the communication between the BL20 station and the other fieldbus stations.

The communication within the BL20 station between the gateway and the individual BL20 modules is regulated via an internal module bus.



Note

The gateway is the only fieldbus-dependent module on a BL20 station. All other BL20 modules are not dependent on the fieldbus used.

2.1.1 Flexibility

All BL20 stations can be planned to accommodate the exact number of channels to suit your needs, because the modules are available with different numbers of channels in block and slice design.

A BL20 station can contain modules in any combination, which means it is possible to adapt the system to practically all applications in automated industry.

2.1.2 Compactness

The slim design of the BL20 modules (standard gateway 50.4 mm / 1.98 inch, ECO gateway 34 mm / 1.34 inch, standard slice 12.6 mm / 0.49 inch, ECO slice 13 mm / 0.51 inch and block 100.8 mm / 3.97 inch) and their low overall height favor the installation of this system in confined spaces.

2.1.3 Easy to handle

All BL20 modules of the standard line, with the exception of the gateway, consist of a base module and an electronics module.

The gateway and the base modules are snapped onto a mounting rail. The electronics modules are plugged onto the appropriate base modules.

The base modules of the standard line are designed as terminal blocks. The wiring is secured by tension clamp or screw connection.

The electronics modules can be plugged or pulled when the station is being commissioned or for maintenance purposes, without having to disconnect the field wiring from the base modules.

The ECO electronics modules combine base module and electronics module in one housing. All BL20-ECO modules can be used with the standard products with tension clamp connection technology.

2.2 BL20 components

2.2.1 Gateways

The gateway connects the fieldbus to the I/O modules. It is responsible for handling the entire process data and generates diagnostic information for the higher-level master and the software tool I/O-ASSISTANT.

ECO-gateways

The BL20-ECO gateways enlarge the product portfolio of BL20. They offer an excellent cost/performance ratio.

Further advantages of the gateways in the ECO-housing:

- At the moment available for PROFIBUS-DP, DeviceNet™, CANopen, Modbus TCP, EtherNet/IP™, EtherCAT® and PROFINET®
- Low required space: width 34 mm/ 1.34 inch minimal space requirements
- Can be combined with all existing standard modules (with tension clamp connection technology) and ECO modules
- Simple wiring with "Push-in" tension clamp terminals, via DeviceNet™-Open Style Connector or via Ethernet RJ45-connectors
- Automatic bit rate detection for PROFIBUS-DP and DeviceNet™
- Setting of fieldbus address and bus terminating resistor (PROFIBUS-DP, DeviceNet™, CANopen) via DIP-switches
- Service interface for commissioning with I/O-ASSISTANT 3 (FDT/DTM), without PLC

Figure 2-1:
Gateway
BL20-E-GW-EN



Gateways with integrated power supply

All standard gateways BL20-GWBR-xxx as well as the BL20-gateways for DPV1 and Ethernet (BL20-GW-DPV1, BL20-GW-EN, BL20-GW-EN-IP, BL20-GW-EN-PN, BL20-PG-EN and BL20-PG-EN-IP) offer an integrated power supply unit for feeding the gateway and the connected I/O modules.

It is not necessary to supply each individual module with a separate voltage.

Gateways without integrated power supply



Note

The gateways without integrated power supply unit need an additional power supply module (bus refreshing module) which feeds the gateway and the connected I/O modules.

2.2.2 Power distribution modules

The power supply for gateways and I/O modules is fed to the power distribution modules; therefore, it is not necessary to supply each individual module with a separate voltage.

Figure 2-2:
Power distribu-
tion module

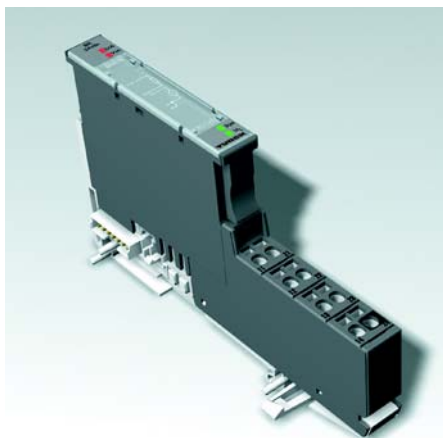

2.2.3 Electronics modules (standard product line)

The standard electronics modules contain the I/O-functions of the BL20 modules (power distribution modules, digital and analog input/output modules, and technology modules).

They are plugged onto the base modules and are not directly connected to the wiring and can be plugged or pulled when the station is being commissioned or for maintenance purposes, without having to disconnect the field wiring from the base modules.

Figure 2-3:
Electronics
module in slice
design (left) and
in Block design
(right)

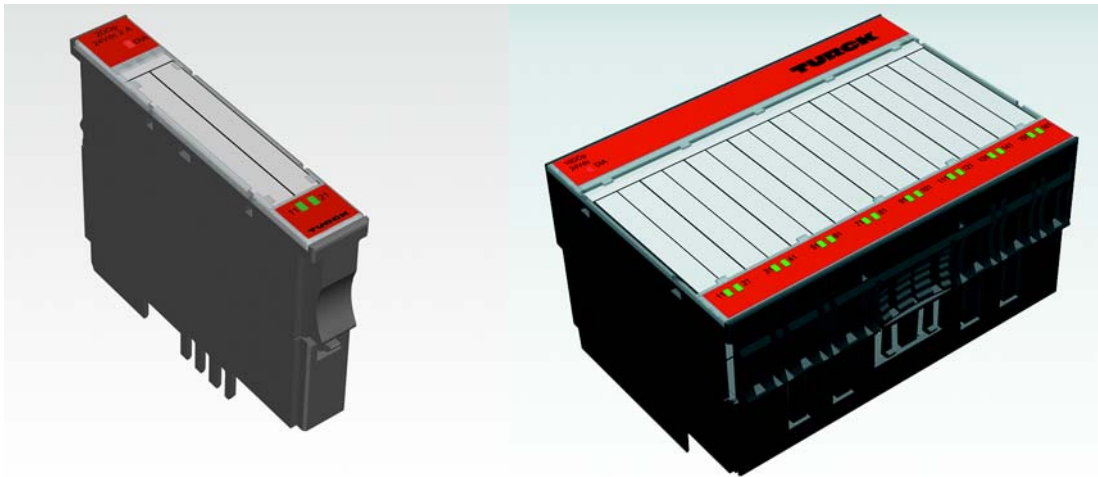

2.2.4 ECO electronics modules

New ECONOMY modules with a high signal density and exceptionally low channel price expand the BL20 I/O bus terminal system.

Depending on type, up to 16 digital inputs and outputs can be connected on only 13 mm. This high connection density considerably reduces the mounting width required for typical applications.

All advantages at a glance:

- Space saving thanks to 16 channels on 13 mm/ 0.51 inch width
- Cost saving thanks to electronics with integrated connection level
- High signal density
- Tool-less connection via "push-in" spring-type terminal technology for simple and fast mounting
- Flexibility in combining them with standard I/O-modules in tension clamp technology, the standard- and the ECO-gateways.
- Simple assembly reduces error sources

Figure 2-4:
ECO I/O-module



2.2.5 Base modules

The field wiring is connected to the base modules. These are constructed as terminals in block and slice designs and are available in the following variations with either tension clamp or screw connections: 2-/3-wire (2-channel), 4-wire (2-channel) and 4 x 2-/3-wire (4-channel).

*Figure 2-5:
Base module
with tension
clamp connec-
tion*

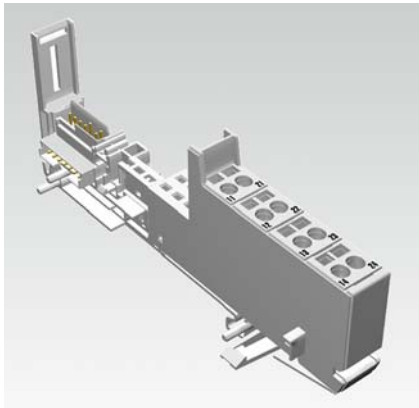

*Figure 2-6:
Base module
with screw
connection*

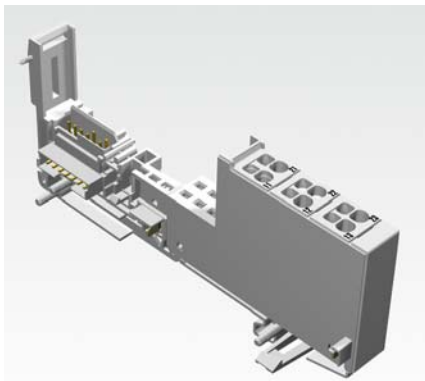

*Figure 2-7:
Base module in
block design*

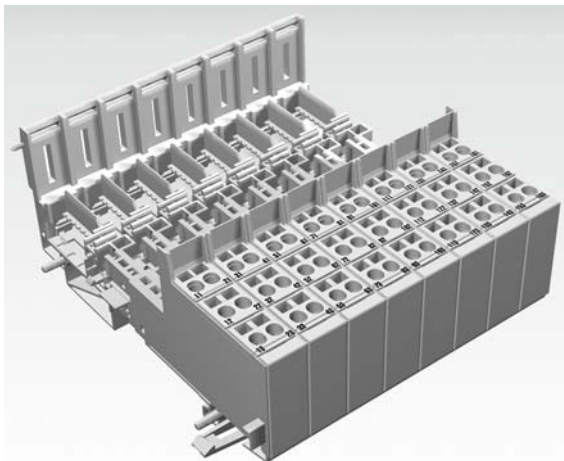

2.2.6 End plate

An end plate on the right-hand side physically completes the BL20 station. An end bracket mounted into the end plate ensures that the BL20 station remains secure on the mounting rail even when subjected to vibration.

Figure 2-8:
End plate

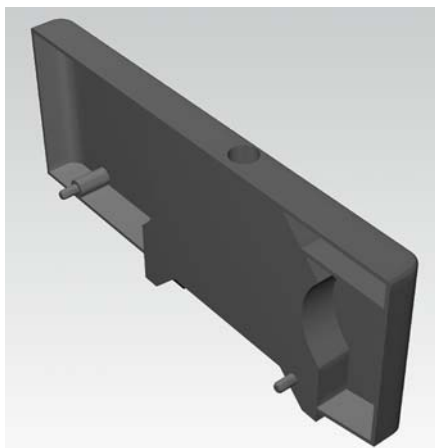

2.2.7 End bracket

A second end bracket to the left of the gateway is necessary, as well as the one mounted into the end plate to secure the station.

Figure 2-9:
End bracket

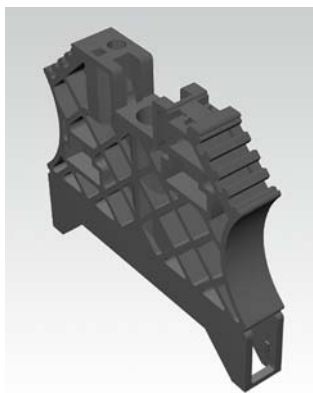

Note

The end plate and two end brackets are delivered with the gateway.

2.2.8 Jumpers

Jumpers (QVRs) are used to bridge a connection level of a 4-wire base module. They can be used to connect potentials in relay modules (bridging the relay roots); thus considerably reducing the amount of wiring.

Figure 2-10:
Jumpers

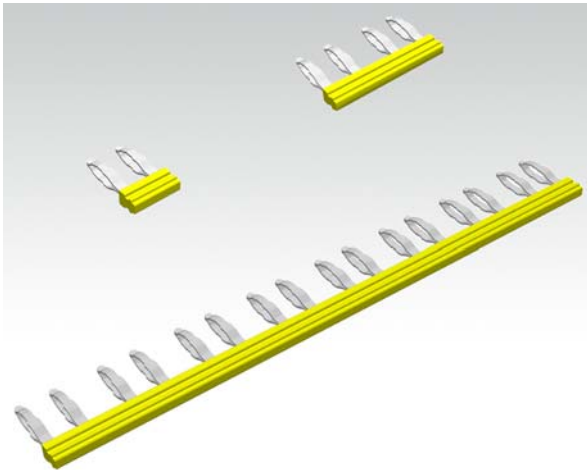

2.2.9 Marking material

- Labels: for labeling BL20 electronics modules.
- Markers: for colored identification of connection levels of BL20 base modules.
- Dekafix connector markers: for numbering the mounting slots on BL20 base modules.

Figure 2-11:
Marking material

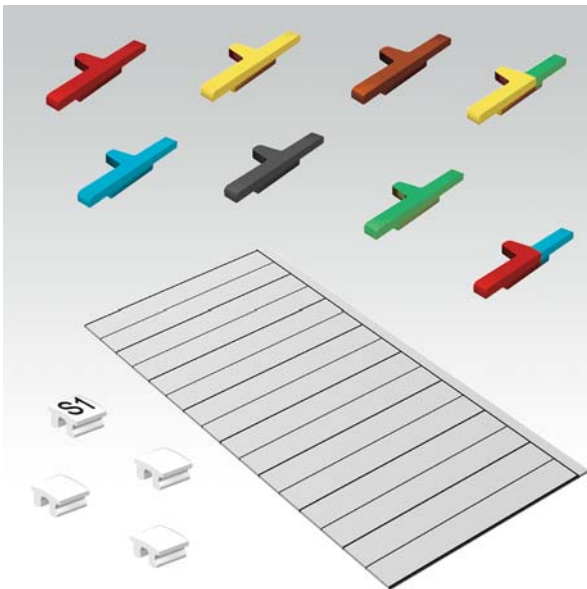

2.2.10 Shield connection gateway

If the gateway is wired directly to the fieldbus, it is possible to shield the connection using a special gateway-shielding connection attachment (BS3511/KLBUE4-31.5).

*Figure 2-12:
Shield connection
(gateway)*

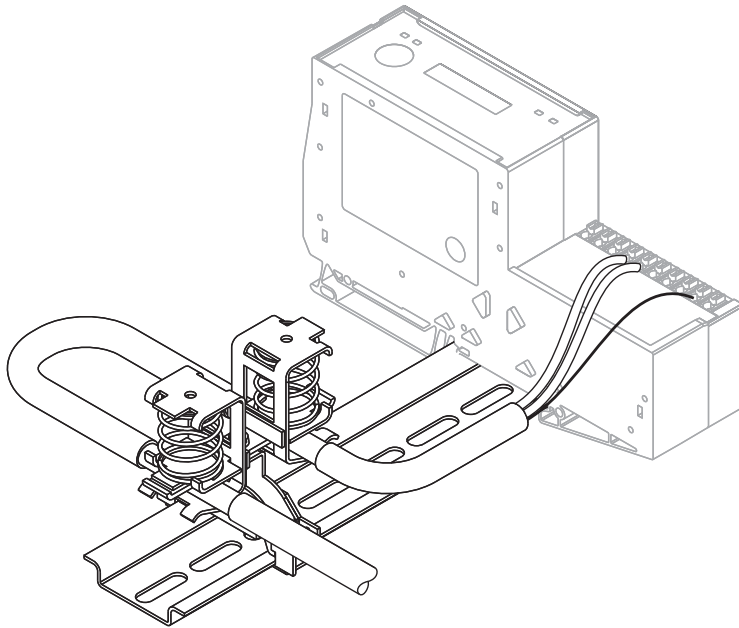

3 Properties: gateway and I/O-modules

3.1	Function of the gateway	3
3.1.1	Version overview	3
3.2	Supported I/O-modules	4
3.3	Technical data.....	6
3.3.1	Top view BL20-E-GW-EN (< VN 03-00)	6
3.3.2	Top view BL20-E-GW-EN (≥ VN 03-00)	7
3.3.3	Block diagram.....	8
3.3.4	General technical data of a station	9
	– Approvals and tests.....	11
3.3.5	Technical data for the push-in tension clamp terminals	11
3.3.6	LED-displays.....	12
3.4	Connection options at the gateway.....	14
3.4.1	Power supply	14
3.4.2	Field bus connection via Ethernet-switch.....	14
3.4.3	Service interface	14
3.5	Address assignment.....	15
	– LED behavior.....	15
3.5.1	Default setting of the gateway.....	15
3.5.2	Function of DIP-switches.....	16
3.5.3	Resetting the IP-address, switch position "RESTORE"	17
3.5.4	Address setting via DIP-switches (2 ⁰ to 2 ⁷)	18
3.5.5	Address setting via the mode DHCP	19
3.5.6	Address setting via the mode BootP.....	20
3.5.7	Address setting via the mode PGM	21
3.5.8	Address setting via the mode PGM-DHCP (universal mode)	22
	– PROFINET®	22
3.5.9	F_Reset (Reset to factory setting).....	22
3.5.10	Addressing via I/O-ASSISTANT 3 (FDT/DTM).....	23
3.5.11	Addressing via Web server (Version ≥ VN 03-00).....	26
3.5.12	Addressing via IP Address Tool	27
3.6	Synchronization of the station configuration	28
3.6.1	DIP-switch CFG.....	28
3.7	Web server - remote access/configuration (Version ≥ VN 03-00)	29
3.7.1	IP address	29
3.7.2	Access rights	29
3.7.3	Login / password.....	30
3.7.4	Network Configuration	30
3.7.5	Gateway Configuration.....	31
3.7.6	Station Diagnostics.....	31
3.7.7	Ethernet Statistics	31
3.7.8	Links	31
3.7.9	Change Admin Password	32

3.8	Status and Control Word of the BL20-stations.....	33
3.8.1	Status Word	33
	– Meaning of the status bits.....	33
3.8.2	Control Word.....	33
3.9	Parameters of the I/O-modules	34
3.9.1	Digital input modules	34
3.9.2	Analog input modules	34
3.9.3	Analog output modules	43
3.9.4	Technology modules.....	48
3.10	Diagnostic messages of the modules.....	57
3.10.1	Power distribution modules	57
3.10.2	Digital input modules	58
3.10.3	Analog input modules	58
3.10.4	Digital output modules	61
3.10.5	Analog output modules	63
3.10.6	Technology modules.....	64

3.1 Function of the gateway

The BL20-E-GW-EN (> VN 03-00) is used as multiprotocol-interface between the BL20-system and the Ethernet-protocols Modbus TCP, EtherNet/IP™ and PROFINET®.

3.1.1 Version overview

Please observe, that the previous version of the gateway did only support the Modbus TCP protocol.

- Version < **VN 03-00**
BL20-gateway supports only the Ethernet protocol
 - Modbus TCP
- Version ≥ **VN 03-00**
BL20-gateway supports the Ethernet protocols
 - Modbus TCP
 - EtherNet/IP™
 - PROFINET®



Note

The multiprotocol gateway replaces the Modbus TCP version and is fully compatible. Only the LED-designation has changed. Please find detailed information under [LED-displays \(page 3-12\)](#).

3.2 Supported I/O-modules

Table 3-1:
List of supported
modules

Module	EtherNet/IP™	Modbus TCP	PROFINET®
<i>Digital input modules</i>			
BL20-2DI-24VDC-P	✓	✓	✓
BL20-2DI-24VDC-N	✓	✓	✓
BL20-2DI-120/230VAC	✓	✓	✓
BL20-4DI-24VDC-P	✓	✓	✓
BL20-4DI-24VDC-N	✓	✓	✓
BL20-4DI-NAMUR	✓	✓	✓
BL20-E-8DI-24VDC-P	✓	✓	✓
BL20-16DI-24VDC-P	✓	✓	✓
BL20-E-16DI-24VDC-P	✓	✓	✓
BL20-32DI-24VDC-P	✓	✓	✓
<i>Analog input modules</i>			
BL20-1AI-I(0/4...20MA)	✓	✓	✓
BL20-2AI-I(0/4...20MA)	✓	✓	✓
BL20-1AI-U(-10/0...+10VDC)	✓	✓	✓
BL20-2AI-U(-10/0...+10VDC)	✓	✓	✓
BL20-2AI-PT/NI-2/3	✓	✓	✓
BL20-2AI-THERMO-PI	✓	✓	✓
BL20-2AI-H			✓
BL20-4AI-U/I	✓	✓	✓
BL20-E-4AI-TC	✓	✓	✓
BL20-E-8AI-U/I-4AI-PT/NI	✓	✓	✓
<i>Digital output modules</i>			
BL20-2DO-24VDC-0,5A-P	✓	✓	✓
BL20-2DO-24VDC-0,5A-N	✓	✓	✓
BL20-2DO-24VDC-2A-P	✓	✓	✓
BL20-2DO-120/230VAC-0.5A	✓	✓	✓
BL20-4DO-24VDC-0,5A-P	✓	✓	✓
BL20-E-8DO-24VDC-0.5A-P	✓	✓	✓
BL20-16DO-24VDC-0,5A-P	✓	✓	✓

Table 3-1:
List of supported
modules

Module	EtherNet/IP™	Modbus TCP	PROFINET®
BL20-E-16DO-24VDC-0.5A-P	✓	✓	✓
BL20-32DO-24VDC-0,5A-P	✓	✓	✓
<i>Analog output modules</i>			
BL20-1AO-I(0/4...20MA)	✓	✓	✓
BL20-2AO-I(0/4...20MA)	✓	✓	✓
BL20-2AO-U(-10/0...+10VDC)	✓	✓	✓
BL20-2AO-H			✓
BL20-E-4AO-U/I	✓	✓	✓
<i>Relay modules</i>			
BL20-2DO-R-NC	✓	✓	✓
BL20-2DO-R-NO	✓	✓	✓
BL20-2DO-R-CO	✓	✓	✓
<i>Technology modules</i>			
BL20-1RS232	✓	✓	✓
BL20-1RS485/422	✓	✓	✓
BL20-1SSI	✓	✓	✓
BL20-E-1SWIRE	✓	✓	✓
BL20-E-2CNT-2PWM	✓	✓	✓
BL20-2RFID-A			✓
BL20-2RFID-S	✓	✓	✓
<i>Power distribution modules</i>			
BL20-BR-24VDC-D	✓	✓	✓
BL20-BR-24 VDC-RED	✓	✓	✓
BL20-PF-24VDC-D	✓	✓	✓
BL20-PF-120/230VAC-D	✓	✓	✓

3.3 Technical data

3.3.1 Top view BL20-E-GW-EN (< VN 03-00)

Figure 3-1:

Top view

BL20-E-GW-EN

(< VN 03-00)

A LEDs for BL20 module bus

B service interface, no function

C DIP-switch for the fieldbus-address

D DIP-switch for the operation mode

E DIP-switch for the configuration acceptance

F LEDs for the Modbus-communication

G EtherNet-switch with EtherNet-LEDs

H terminals for field supply

I terminals for system supply

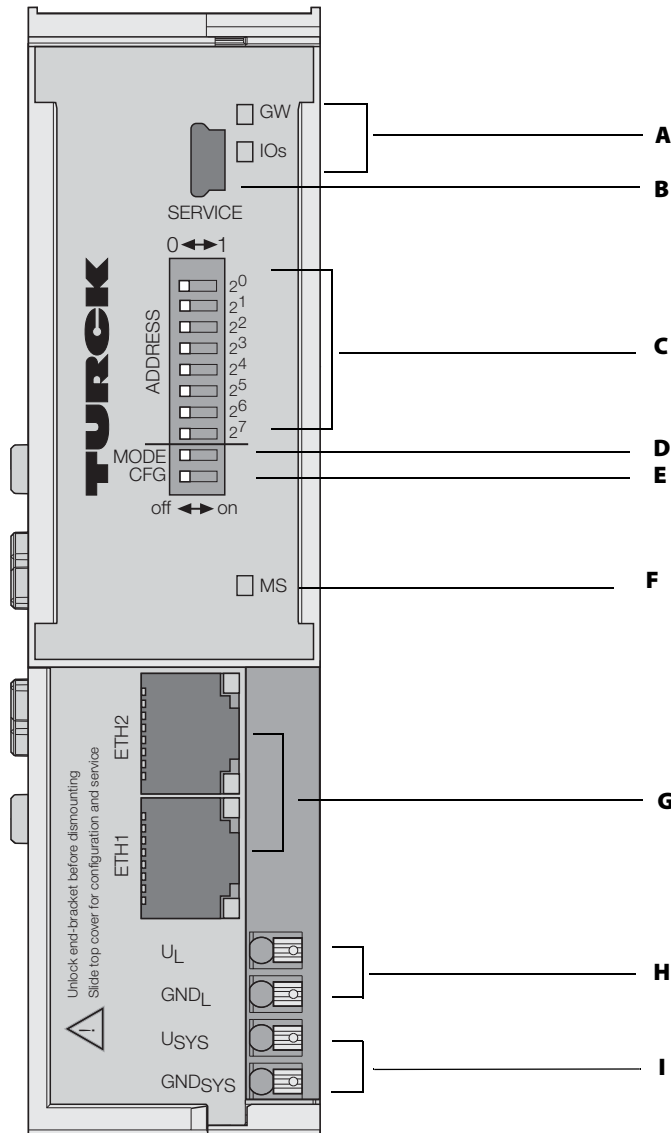

3.3.2 Top view BL20-E-GW-EN (≥ VN 03-00)

Figure 3-2:
Topview
BL20-E-GW-EN
(≥ VN 03-00)

- A** LEDs for BL20 module bus
- B** service interface, no function
- C** DIP-switch for the fieldbus-address
- D** DIP-switch for the operation mode
- E** DIP-switch for the configuration acceptance
- F** LEDs for the Ethernet-communication
- G** EtherNet-switch with EtherNet-LEDs
- H** terminals for field supply
- I** terminals for system supply

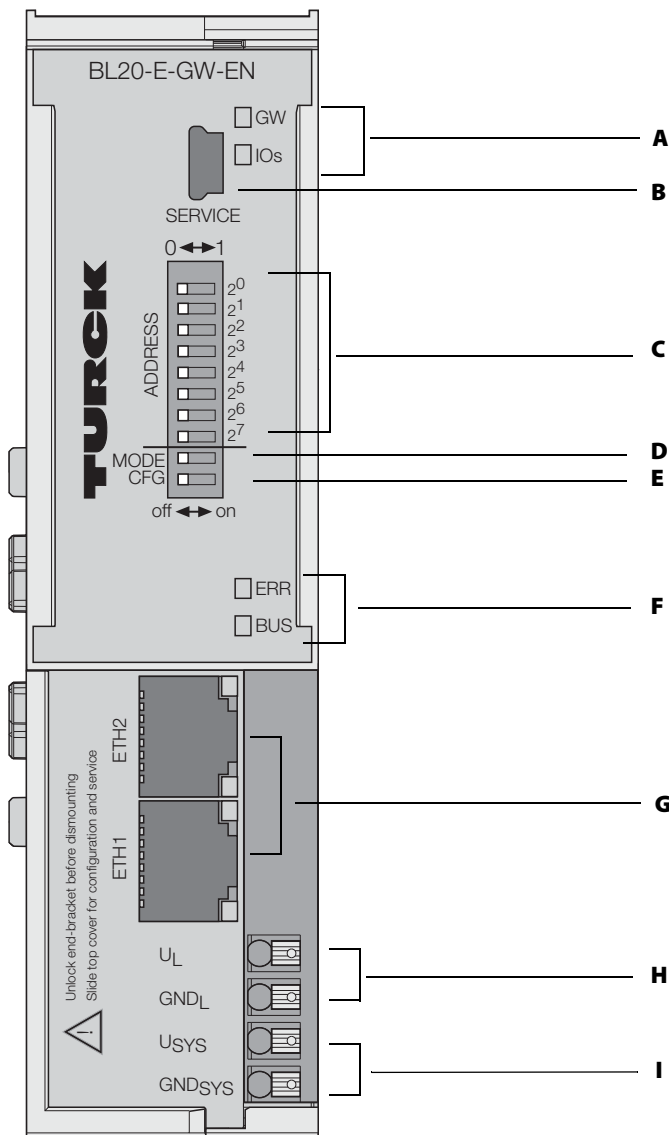

3.3.3 Block diagram

Figure 3-3:
Block diagram
BL20-E-GW-EN

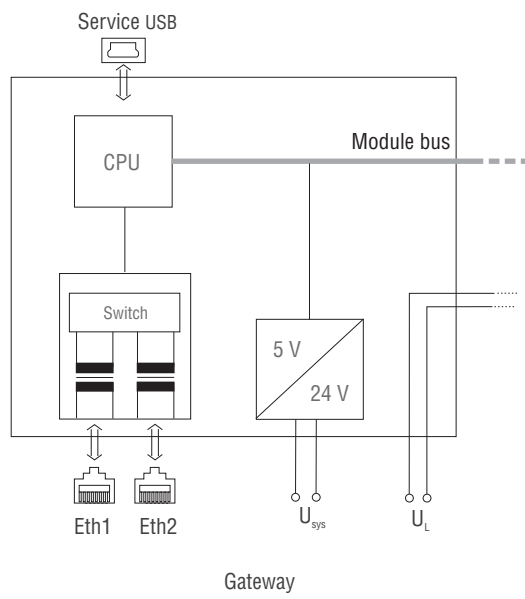

3.3.4 General technical data of a station



Attention

The auxiliary power supply must comply with the stipulations of SELV (Safety Extra Low Voltage) according to IEC 364-4-41.

Table 3-2:
General technical data of a station

Supply voltage/auxiliary voltage	
U _{sys} (nominal value) provision for other modules	24 V DC
I _{sys} (at max. system extension, → see chapter 10 , from page 10-3)	approx. 600 mA
U _L nominal value	24 V DC
I _{Lmax} maximum current from field supply	8 A
permissible range	according to EN 61 131-2 (18 to 30 V DC)
Residual ripple	according to EN 61 131-2
Voltage anomalies	according to EN 61 131-2
I _{MB} (supply of module bus nodes)	400 mA
Connection technology	push-in tension clamps, LSF from Weidmueller
Physical interfaces	
Field bus	Ethernet
Transmission rate	10/100 Mbps
Passive fiber-optic-adapters can be connected	current consumption max. 100 mA
Fieldbus connection technology	RJ45-female connector, RJ45-male connector
Fieldbus shielding connection	via Ethernet cable
Address setting	via DIP-switches (2 ⁰ to 2 ⁷)
service interface	Ethernet
Isolation voltages	
U _{BL} (U _{sys} against service interface)	-
U _{ETH} (supply voltage against Ethernet)	500 V AC
U _{ETH} (supply voltage against Ethernet)	-
U _{ETHETH} (ETH1 against ETH2)	500 V AC

Ambient conditions	
Ambient temperature	
- t _{Ambient}	0...+55 °C
- t _{Store}	- 25...+85 °C
relative humidity according to EN 61131-2/EN 50178	5 to 95 % (indoor), Level RH-2, no condensation (storage at 45 °C, no function test)
Climatic tests	according to IEC 61131-2
Vibration resistance	
10 to 57 Hz, constant amplitude 0.075 mm / 0.003 inch, 1g	yes
57 to 150 Hz constant acceleration 1 g	yes
Mode of vibration	Frequency sweeps with a change in speed of 1 Octave/min
Period of oscillation	20 frequency sweeps per axis of coordinate
Shock resistant according to IEC 68-2-27	18 shocks, sinusoidal half-wave 15 g peak value/11 ms, in each case in ± direction per space coordinate
Resistance to repetitive shock IEC 68-2-29	1 000 shocks, half-sinus 25 g peak value/6 ms, in each case in ± direction per space coordinate
Drop and topple	
Height of fall (weight < 10 kg)	1.0 m
Height of fall (weight 10 to 40 kg)	0.5 m
Test runs	7
Device with packaging, electrically tested printed-circuit board.	
Electromagnetic compatibility (EMC) according to EN 50 082-2 (Industry)	
Static electricity according to EN 61 000-4-2	
- Discharge through air (direct)	8 kV
- Relay discharge (indirect)	4 kV
Electromagnetic HF fields according to EN 61 000-4-3 and ENV 50 204	10 V/m
Conducted interferences induced by HF fields according to EN 61 000-4-6	10 V
Fast transients (Burst) according to EN 61 000-4-4	
Emitted interference according to EN 50 081-2 (industry)	according to EN 55 011 Class A A , group 1

A Using the device in residential areas can cause disturbances. In this case, additional measures to suppress the disturbance are necessary.

Approvals and tests

Table 3-3:
Approvals and tests for a BL20 station

Designation	
Approvals	
UL CSA	in preparation
Tests (EN 61131-2)	
Cold	DIN IEC 68-2-1, Temperature -25 °C / 185 °F, duration 96 h; device not in use
Dry heat	DIN IEC 68-2-2, Temperature +85 °C / 185 °F, duration 96 h; device not in use
Damp heat, cyclic	DIN IEC 68-2-30, temperature +55 °C / 131 °F, duration 2 cycles every 12 h; device in use
Pollution severity according to IEC 664 (EN 61 131-2)	2
Protection class according to IEC 529	IP20

3.3.5 Technical data for the push-in tension clamp terminals

Table 3-4:
Technical data Push-in tension clamp terminals

Designation	
Protection class	IP20
Insulation stripping length	8 mm + 1/ 0.32 inch + 0,039
Max. wire range	0.14 to 1.5 mm ² / 0.0002 to 0.0023 inch ² / 26 to 16 AWG
Crimpable wire	
"e" solid core H 07V-U	0.14 to 1.5 mm ² / 0.0002 to 0.0023 inch ² / 26 to 16 AWG
"f" flexible core H 07V-K	0.5 to 1.5 mm ² / 0.0008 to 0.0023 inch ² / 25 to 16 AWG
"f" with ferrules according to DIN 46 228/1 (ferrules crimped gas-tight)	0.25 to 1.5 mm ² / 0.0004 to 0.0023 inch ² /30 to 16 AWG



Danger

This device can cause radio disturbances in residential areas and in small industrial areas (residential, business and trading). In this case, the operator can be required to take appropriate measures to suppress the disturbance at his own cost.

3.3.6 LED-displays

Every BL20-E-GW-EN displays the following statuses via LEDs:

- 2 LEDs for the module bus communication (module bus-LEDs): GW and IOs
- < VN 03-00:
 - 1 LEDs for the field bus communication: MS
 - VN ≥ 03-00:
 - 2 LEDs for the field bus communication: ERR and BUS
- 2 LEDs for the status of the Ethernet-connection at the Ethernet-ports ETH1/ ETH2:

Table 3-5:
LED-displays

LED	Status	Meaning	Remedy
GW	OFF	No power supply of the CPU.	Check the system power supply at the gateway.
	green	Firmware active, gateway ready	-
	green flashing, 1 Hz	Firmware not active	If LED "IOs" red, firmware-download necessary
	green flashing, 4 Hz	Firmware active, gateway hardware error.	Replace the gateway.
	red	CPU not ready, V_{CC} too low → possible causes: – too many modules at the gateway – short-circuit in connected module – gateway hardware error.	– Check the system power supply at the gateway and the cabling. – Unmount excessively mounted modules. – Replace the gateway, if necessary.
	red / green flashing, 4 Hz	WINK-command active	
IOs	OFF	No power supply of the CPU.	Check the system power supply at the gateway.
	green	The modules configured correspond to the modules in the station, communication running.	-
	green flashing, 1 Hz	Station is in the Force Mode of the I/O-ASSISTANT.	Deactivate the Force Mode of the I/O-ASSISTANT.
	red	Hardware error, firmware not running.	– Replace the gateway.

Table 3-5:
LED-displays

LED	Status	Meaning	Remedy
IOs	red flashing, 1 Hz	Incompatible deviation of module list. The gateway reports an error. The communication to the field bus is disturbed. A trouble-free process data exchange is not assured.	<ul style="list-style-type: none"> – Compare the configured list of modules in your BL20-station to the current configuration. – Check the physical station for defective or incorrectly plugged electronic modules.
	red flashing, 4 Hz	No communication via the module bus.	– At least one module has to be plugged and has to be able to communicate with the gateway.
	red/green flashing	behavior similar to: red flashing, 1 Hz	–
ERR	OFF	No diagnostic message	–
	red	Pending diagnostic message at the gateway or at one of the connected modules.	– Check the station for diagnostic messages.
BUS (MS)	OFF	Station is not supplied.	– Check the voltage supply at the gateway.
	green	Displays the logical connection to a Master (1. Modbus TCP-connection)	–
	green, flashing	Gateway ready for operation	–
	red	Gateway error: – IP address conflict – gateway in RESTORE-mode – F_Reset activated	<ul style="list-style-type: none"> – Check the IP-addresses in the network – Check the position of the DIP-switches
	red + green	– auto-negotiation and / or – waiting for DHCP- / BootP-address assignment.	–
LEDs at female connectors ETH1/ETH2			
green	OFF	No Ethernet link.	
	ON	Link	
	flashing	Ethernet Traffic	
yellow	ON	100 Mbps	
	OFF	10 Mbps	–

3.4 Connection options at the gateway

The fieldbus connection is realized via an integrated RJ45-Ethernet-switch, the connection of the power supply via push-in tension clamps.

Figure 3-4:
Connection
options at the
gateway

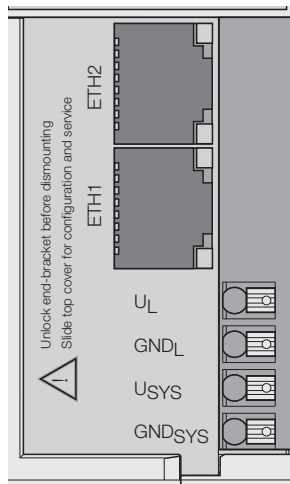

3.4.1 Power supply

The BL20-E-GW-EN provides an integrated power supply unit an push-in tension clamps for:

- Field supply (UL, GNDL)
- and
- system supply (USYS, GNDSYS)

3.4.2 Field bus connection via Ethernet-switch

The BL20-ECO-gateways for Ethernet provide an integrated RJ45-Ethernet-switch.

Figure 3-5:
RJ45 female
connector

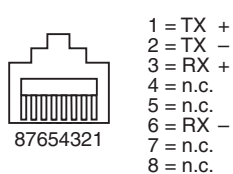

3.4.3 Service interface

The access of the software I/O-ASSISTANT 3 (FDT/DTM) via the service-interface (Mini-USB) is not supported.

For a connection to the gateway via I/O-ASSISTANT 3 (FDT/DTM) is done via Ethernet.

3.5 Address assignment

LED behavior

During the start-up, the flashing LED "BUS" (red/green) displays that the station is waiting for address assignment per DHCP/BOOTP/autonegotiation.

As soon as the address assignment is done, the LED flashes green and the station is ready for communicating in the network.

3.5.1 Default setting of the gateway

The object provides the following control functions:

IP-address	192.168.1.254
Subnet mask	255.255.255.0
Default gateway	



Note

The stations can be reset by the user to these default settings at any time. To reset the module, set the three DIP-switches 2⁰ to 2⁷ on the gateway to "0" followed by a power-on reset.



Note

After every change of the address-mode, a voltage reset must be carried done.

3.5.2 Function of DIP-switches

The DIP-switches for address setting, operation mode setting and for the storage of the station configuration are located under the gateway's upper label.

To set the DIP-switches, please pull the label from the gateway.



Note

Please observe, that the numbering of the DIP-switches under the label does not correspond to the switches' designation on the label.

Figure 3-6:
DIP-switches at
the gateway

Top view with label:

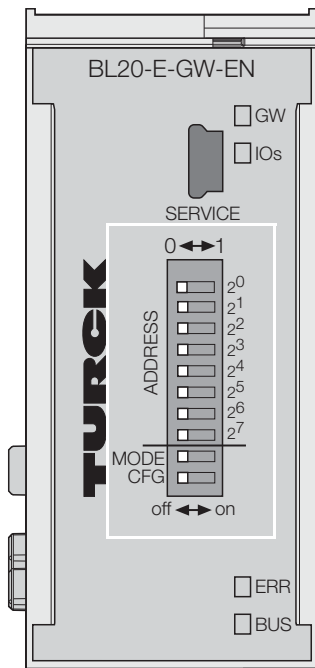

Top view without label:

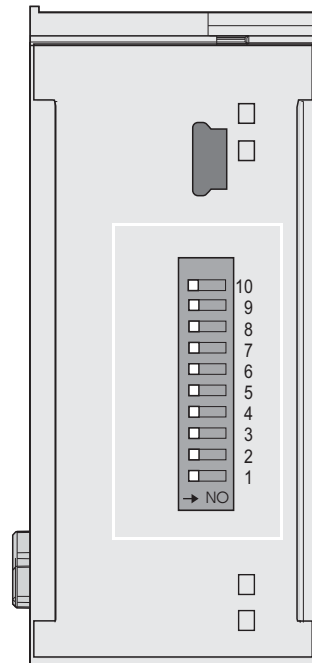

Table 3-6:
Meaning of the
DIP-switches

Designation	Function
under label	
Label	
2 ⁰ - 2 ⁷	10 - 3 Address-switch for setting the last byte of the gateway's IP-address (only, if "MODE" is OFF (see Table 3-7: Combinations of address-switches (page 3-17))).
MODE	2 Depending on its setting, this switch changes the function of address switches 2 ⁰ - 2 ⁷ (see Table 3-7: Combinations of address-switches (page 3-17)).
CFG	1 Switching from "OFF" to "ON" activates the „Synchronization of the station configuration“.



Note

The setting of DIP-switch 2⁷ (CFG) and 2⁶ (MODE) is also important for the firmware download. Please read [Firmware-Download \(page 10-11\)](#).

Table 3-7:
Combinations
of address-
switches

Address-switches $2^0 - 2^7$ (Value)	CFG	MODE	Name	Function
0	OFF	OFF	RESTORE	Restoring the Default setting of the gateway (page 3-15) .
1-254	OFF	OFF	Address	Setting the last byte of the gateway's IP-address. Resetting the IP-address, switch position "RESTORE" (page 3-17)
1	OFF	ON	DHCP	gateway-„Address setting via the mode DHCP“
2	OFF	ON	BOOTP	gateway-„Address setting via the mode BootP“
4	OFF	ON	PGM	gateway-„Address setting via the mode PGM“
8	OFF	ON	PGM-DHCP	gateway-„Address setting via the mode PGM-DHCP (universal mode)“
16	OFF	-	-	reserved
32	OFF	ON	F_Reset	
...	reserved			

3.5.3 Resetting the IP-address, switch position "RESTORE"

With this setting the DIP-switches to "0" followed by a voltage reset, the module is set to the address 192.168.1.254 for IP-based services (see [Default setting of the gateway \(page 3-15\)](#)).

This setting allows for example the I/O-ASSISTANT 3 (FDT/DTM) to communicate with the station, the device's WEB-server can be accessed using the IP-address 192.168.1.254.



Note

This setting is no operation mode! Please set the device to another mode after having reset the IP address to the default values.

3.5.4 Address setting via DIP-switches (2^0 to 2^7)

Switch MODE has to be set to "OFF".

Addresses from 1 to 254 can be set.

The addresses 0 and 255 are used for Broadcast-messages in the subnet.



Note

All other network settings are stored in the module's non-volatile EEPROM and can not be changed.

The gateway's field bus address results from the addition of the valences (2^0 to 2^7) of the active DIP-switches (position = 1).



Note

Pull the label upwards out of the housing in order to reach the DIP-switches.

Example:

Bus address 50 = $0 \times 32 = 00110010$

Figure 3-7:
Address setting

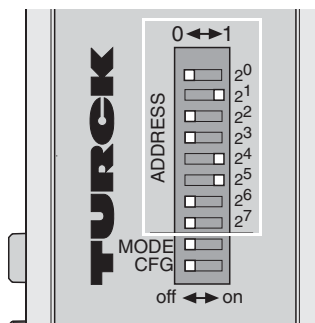

Note

The internal module bus does not require any addressing.



Attention

The settings carried out via DIP-switches 2^0 to 2^7 are not stored in the module's EEPROM. Thus, they will get lost in case of a subsequent address-assignment via a BootP/DHCP or PGM.



Attention

After changing the position of the rotary coding-switches, a voltage reset must be carried out to store the new address.

3.5.5 Address setting via the mode DHCP

Address setting is carried out by a DHCP-server in the network after the start-up of the gateway.

In order to activate the DHCP-mode, the DIP-switch MODE is set to "ON", the address-switches 2⁰ to 2⁷ to address "1" (see [Table 3-7: Combinations of address-switches](#)).

Figure 3-8:
DHCP mode

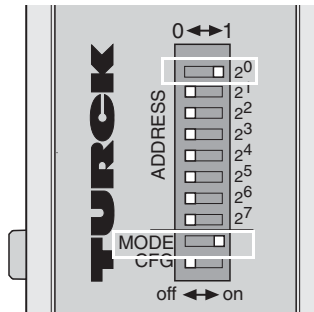

Note

The IP address, as well as the default subnet mask assigned to the gateway by the DHCP-server, are stored in the module's EEPROM.

If the gateway is subsequently switched to another address-mode, the settings (IP address, subnet mask, etc) will be read from the module's EEPROM.



Attention

After every change of the address-mode, a voltage reset must be carried done.

DHCP supports three mechanisms for IP address allocation:

- In "automatic allocation", the DHCP-server assigns a permanent IP address to a client.
- In "dynamic allocation", DHCP assigns an IP address to a client for a limited period of time. After this time, or until the client explicitly relinquishes the address, the address can be re-assigned.
- In "manual allocation", a client's IP address is assigned by the network administrator, and DHCP is used simply to convey the assigned address to the client.

PROFINET®

Please assure, that in PROFINET® -applications, the address assigned via a BootP-server corresponds to the address, which is assigned in the configuration tool.

3.5.6 Address setting via the mode BootP

Address setting is carried out by a BootP-server in the network after the start-up of the gateway.

In order to activate the BootP-mode, the DIP-switch MODE is set to "ON", the address-switches 2^0 to 2^7 to address "2" (see [Table 3-7: Combinations of address-switches](#)).

Figure 3-9:
BootP

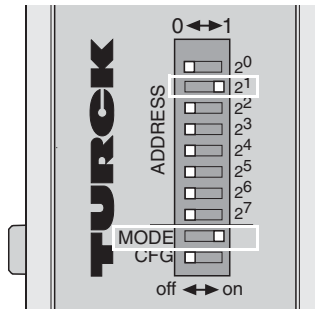

Note

The IP address, as well as the default subnet mask assigned to the gateway by the BootP-server, are stored in the module's EEPROM.

If the gateway is subsequently switched to another address-mode, the settings (IP address, subnet mask, etc) will be read from the module's EEPROM.

PROFINET®

Please assure, that in PROFINET® -applications, the address assigned via a BootP-server corresponds to the address, which is assigned in the configuration tool.

3.5.7 Address setting via the mode PGM

The PGM-mode enables access of the software I/O-ASSISTANT (FDT/DTM) to the module's network settings (see also „Addressing via I/O-ASSISTANT 3 (FDT/DTM)“).

In order to activate the PGM-mode, the DIP-switch MODE is set to "ON", the address-switches 2^0 to 2^7 to address "4" (see [Table 3-7: Combinations of address-switches](#)).

Figure 3-10:
PGM

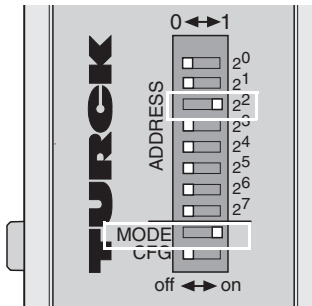

Note

In the PGM-mode, all network settings (IP address, subnet mask, etc.) are read from the module's internal EEPROM.



Attention

After every change of the address-mode, a voltage reset must be carried done.

3.5.8 Address setting via the mode PGM-DHCP (universal mode)

Figure 3-11:
PGM-DHCP

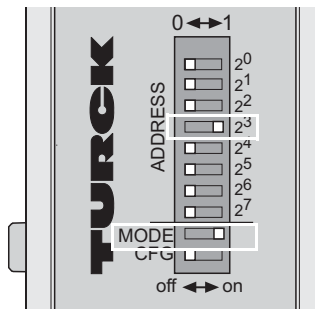

The device sends DHCP-requests until a IP-address is assigned (DHCP-server, PROFINET®-controller). The assigned IP-address is stored to the device and the DHCP-client is stopped. Even after a restart of the device, the device sends no further DHCP-requests.

PROFINET®

This mode assures a PROFINET®-compliant operation of the modules.



Note

If a DHCP-server is used within the network, problems may occur during IP-assignment. In this case, both, the DHCP-server as well as the PROFINET®-controller (via DCP), try an IP-address-assignment.

3.5.9 F_Reset (Reset to factory setting)

Figure 3-12:
F_Reset

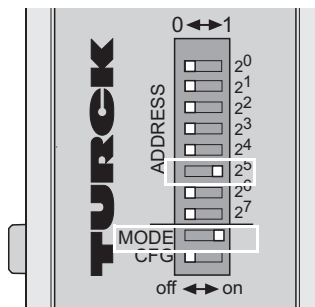

This mode sets all device-settings back to the default values and deletes all data in the device's internal flash.



Note

This setting is no operation mode! Please set the device to another mode after having reset the IP address to the default values.

3.5.10 Addressing via I/O-ASSISTANT 3 (FDT/DTM)

The software-tool I/O-ASSISTANT 3 (FDT/DTM) enables direct access to the Ethernet-network via the Ethernet cable.

The IP address, as well as the subnet mask of the TURCK Ethernet stations, can be changed according to the application by using the Busaddress Management function of the BL Service Ethernet interface (TCP/IP) in the software I/O-ASSISTANT 3 (FDT/DTM).

Figure 3-13:
Busaddress
management

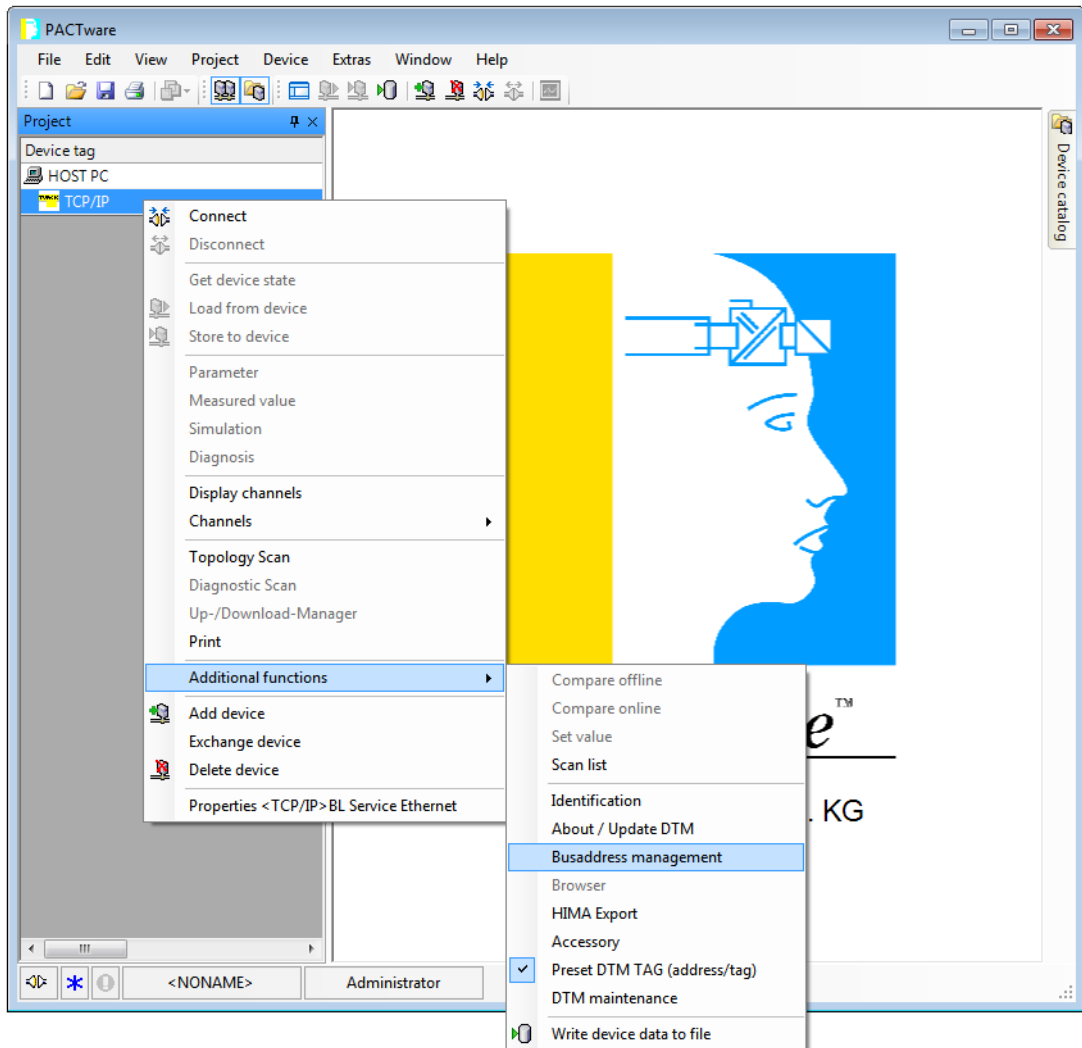
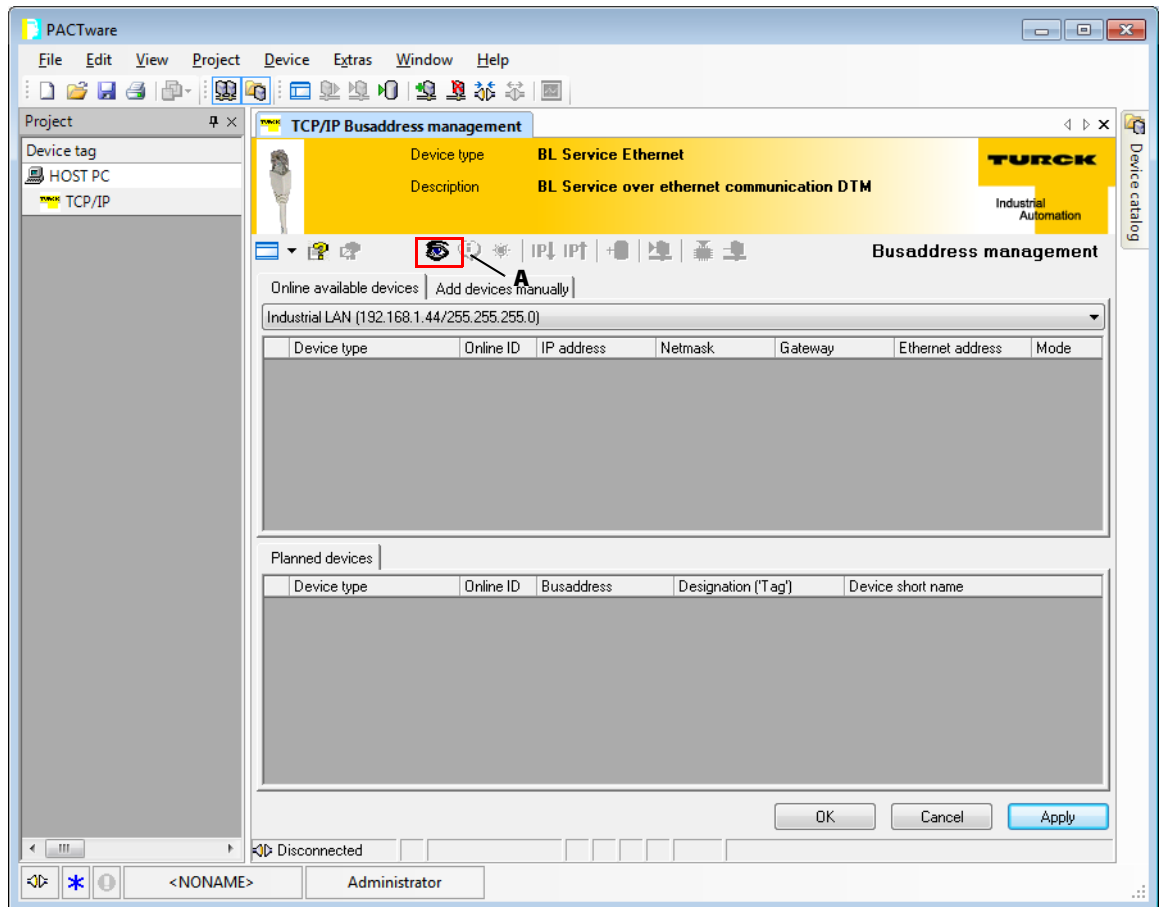

Figure 3-14:
Searching
network-
Nodes in the
Busaddress
management

A Search function
in the Busad-
dress manage-
ment



Note

The access of the IO-ASSISTANT to the station is only possible, if the station already has an IP-address (see [Address assignment \(page 3-15\)](#)) and if it is operated in switch position PGM or PGM-DHCP-mode.



Note

When using Windows XP as operating system, difficulties may occur with system-integrated firewall.

It may inhibit the access of PACTware™ (I/O-ASSISTANT V3) to the Ethernet-network. In this case, please adapt your firewall respectively or deactivate it.

Figure 3-15:
IP address
change

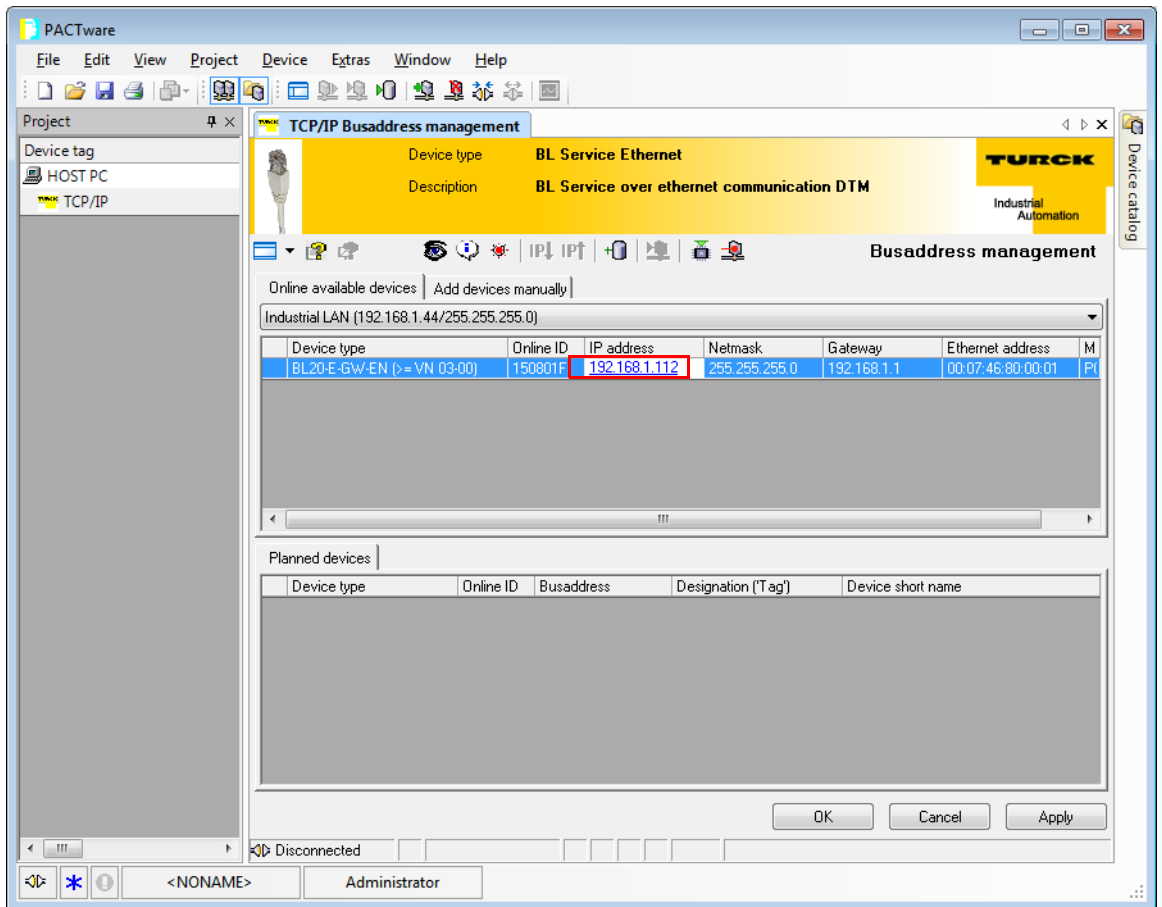

3.5.11 Addressing via Web server (Version ≥ VN 03-00)

The device's network settings can be changed under "Network Configuration" only by users having administrator rights.

Further information concerning the web server of the FGEN-devices and it's use can be found under [Web server - remote access/configuration \(Version ≥ VN 03-00\) \(page 3-29\)](#).



Note

The access of the IO-ASSISTANT to the station is only possible, if the station already has an IP-address, [Address assignment \(page 3-15\)](#).
and if it is operated in switch position PGM or PGM-DHCP-mode.

Figure 3-16:
Web server with
Network
Configuration

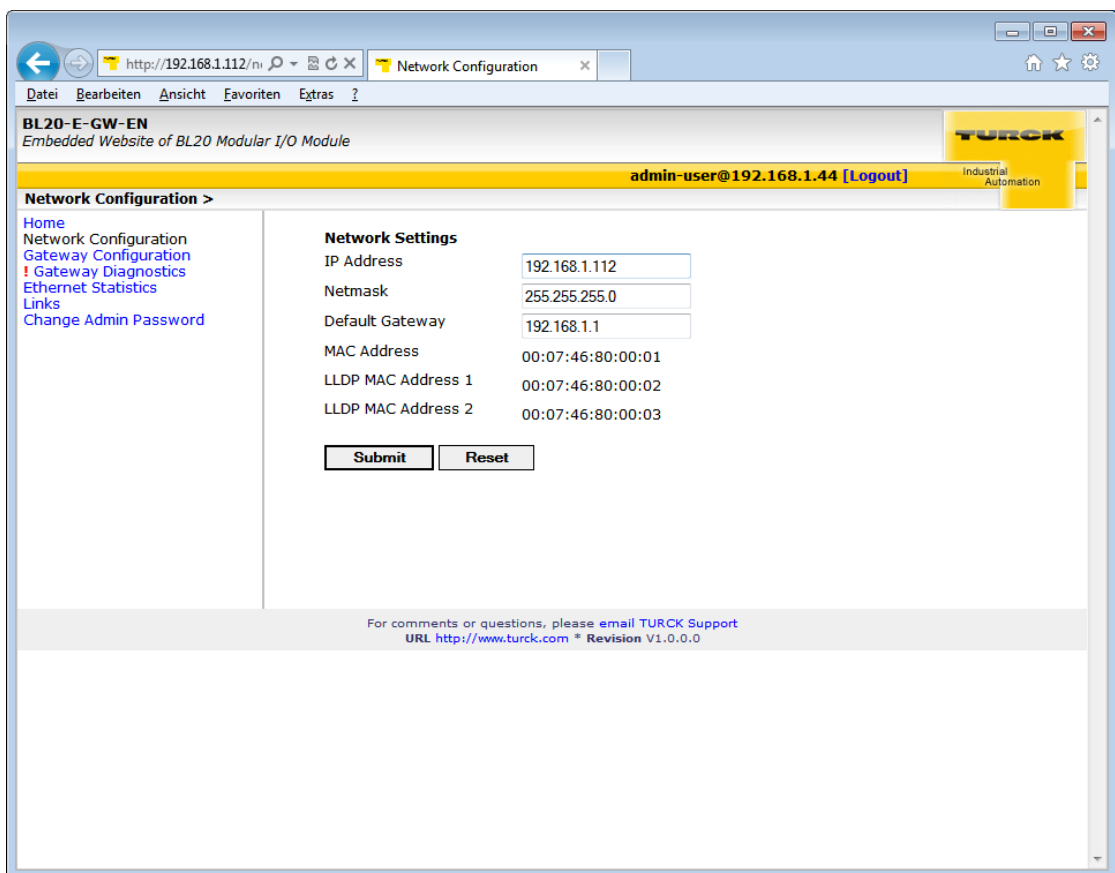

3.5.12 Addressing via IP Address Tool

Use the TURCK IP Address Tool for simple and fast changes in the IP-address of your device.

The software can be downloaded from www.turck.com in the „Download“ area.

The IP Address Tool can be used to:

- search devices,
- change IP-addresses,
- reset devices
- send WINK-commands.

Figure 3-17:
IP Address Tool

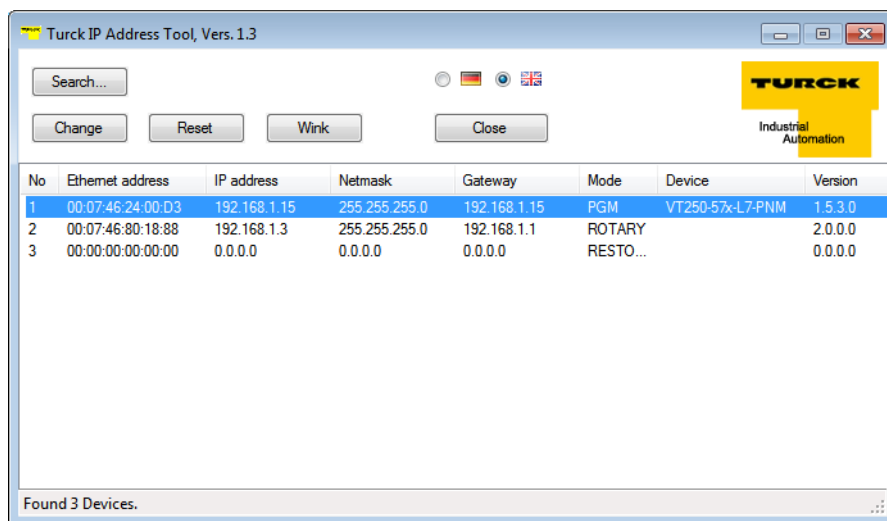

3.6 Synchronization of the station configuration

3.6.1 DIP-switch CFG

The DIP-switch "CFG" at the gateway serves to take-over the Current Configuration of the BL20-station as Required Configuration to the gateway's non-volatile memory.



Note

Storing the Current Configuration via SET-Taster is necessary in EtherNet/IP™ as well as in Modbus TCP, in PROFINET® the referenced configuration is defined by the master.

Figure 3-18:
DIP-switch for
storing the
station configuration

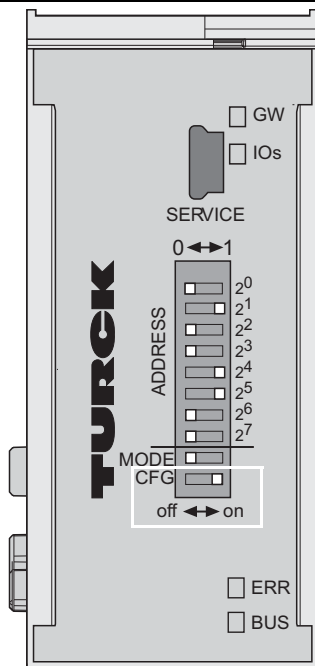

Switching from OFF to ON starts the storage of the Current Configuration as the Required Configuration (Reference configuration).

Procedure:

Switching the DIP-switch "CFG" from OFF to ON

- Starting of storage process
- LED IOs flashes green (1 Hz)
- LED IOs shortly lights up orange
- storage process active
- set back the DIP-switch from ON to OFF
- storage process terminated successfully, if the LEDs IOs and GW are constant green.



Note

If the DIP-switch is not set back, the gateway will continuously restart the storage process. Only setting the switch back from ON to OFF will terminate this process.

3.7 Web server - remote access/configuration (Version ≥ VN 03-00)

3.7.1 IP address

Open the web server by entering the device's IP-address in your web browser.

IF no IP-address is assigned to the device (DHCP-, BootP-server etc.), then the web server can be opened using the default IP-address 192.168.1.254.

3.7.2 Access rights

Without administrator rights, data as general product data and diagnosis data are read only.

In order to achieve administrator rights, please log-on to the web server, see [Login / password](#) (page 3-29).

Figure 3-19:
Web server of
the BL20-station

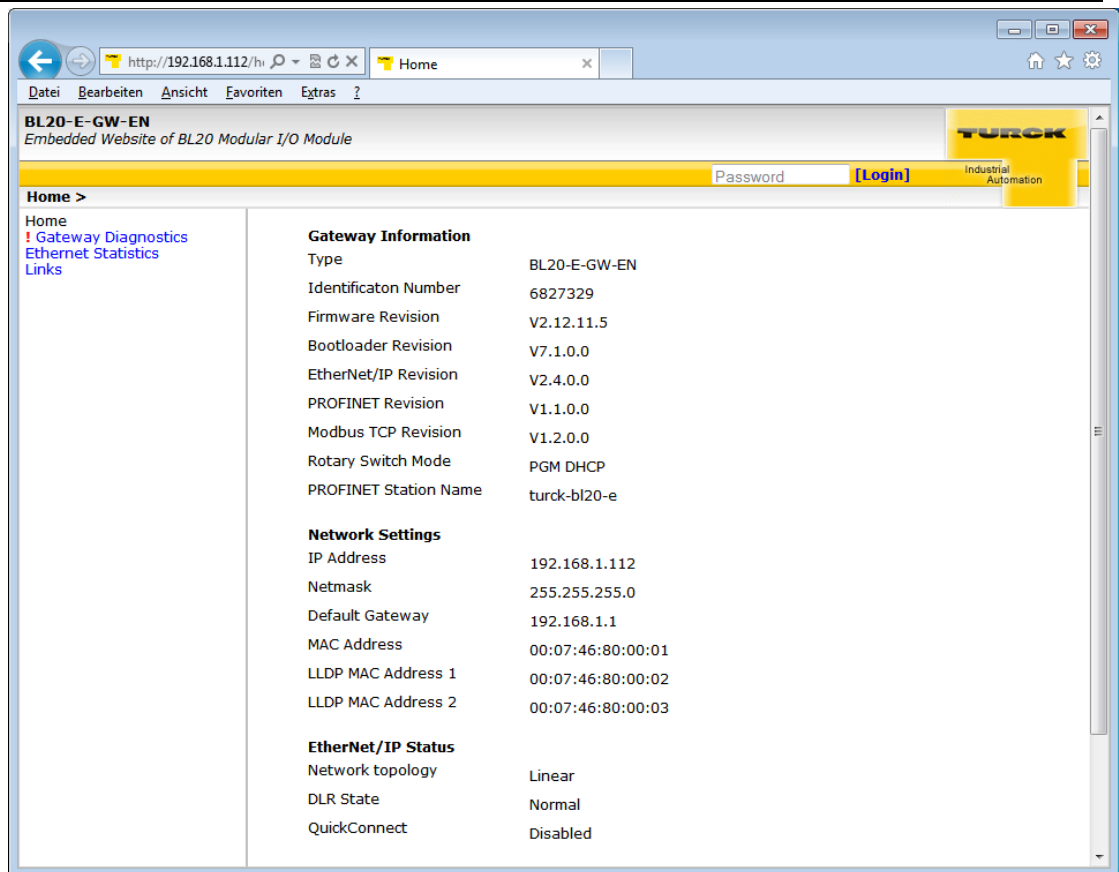

3.7.3 Login / password

Login to the web server by using the default-password "password".

The default-password can be changed by the administrator at every time under [Change Admin Password](#) (page 3-31) .



Note

A reset of the device to the default-settings using the switch position 900 "F_Reset" also causes a reset of the password to "password".

Figure 3-20:
Web server
"Home" screen

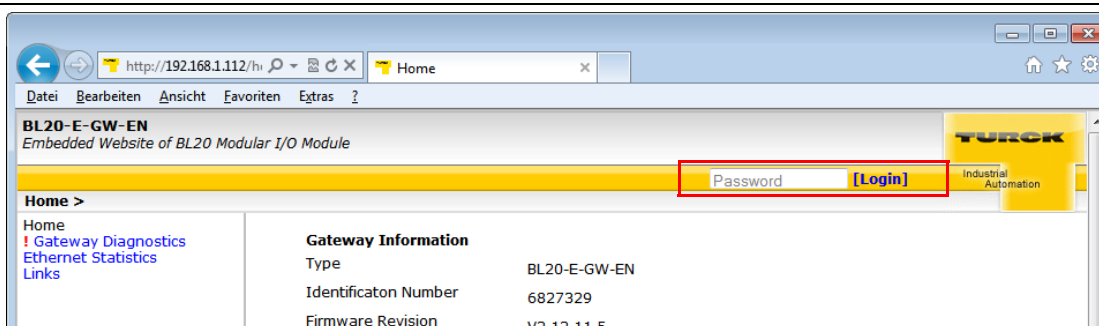

3.7.4 Network Configuration

On the "Network Configuration"-page, network-relevant settings can be changed.

Figure 3-21:
Web server
"Network
Configuration"

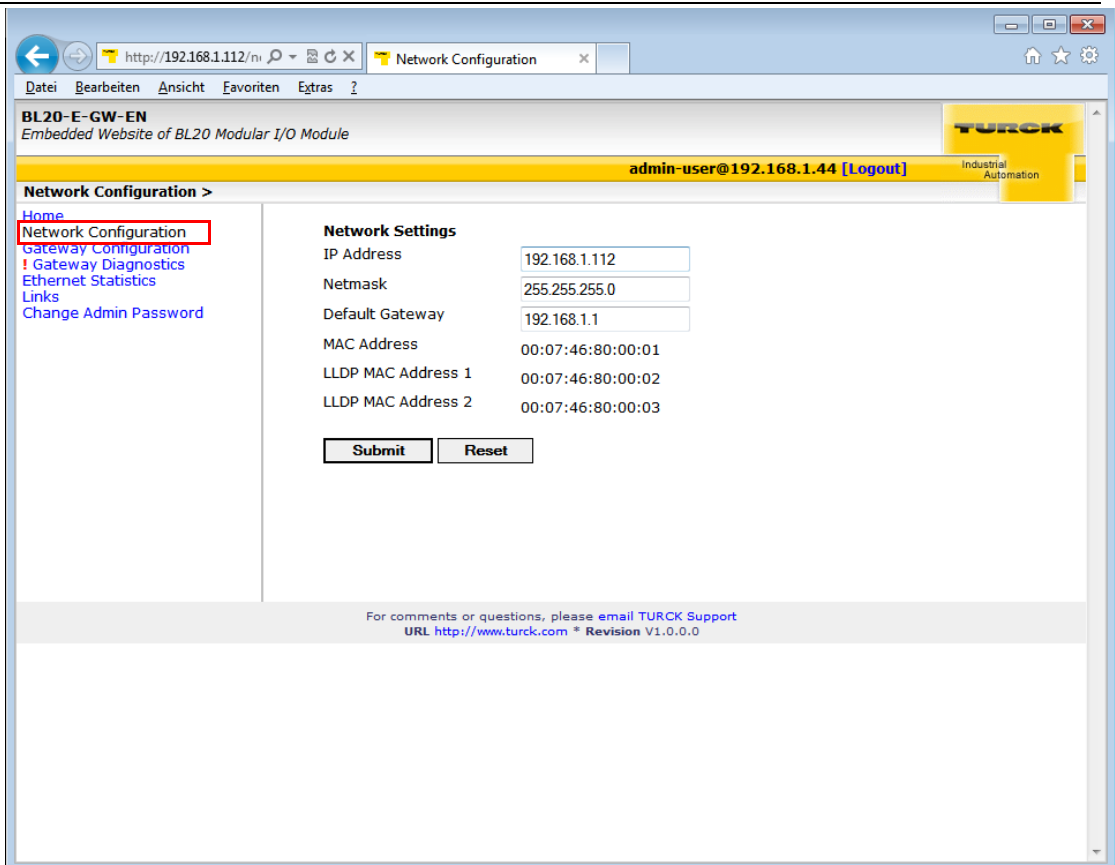

3.7.5 Gateway Configuration

The "Gateway Configuration"-page serves for parameterizing the device's fieldbus interface.

Figure 3-22:
Web server
„Gateway
Configuration“

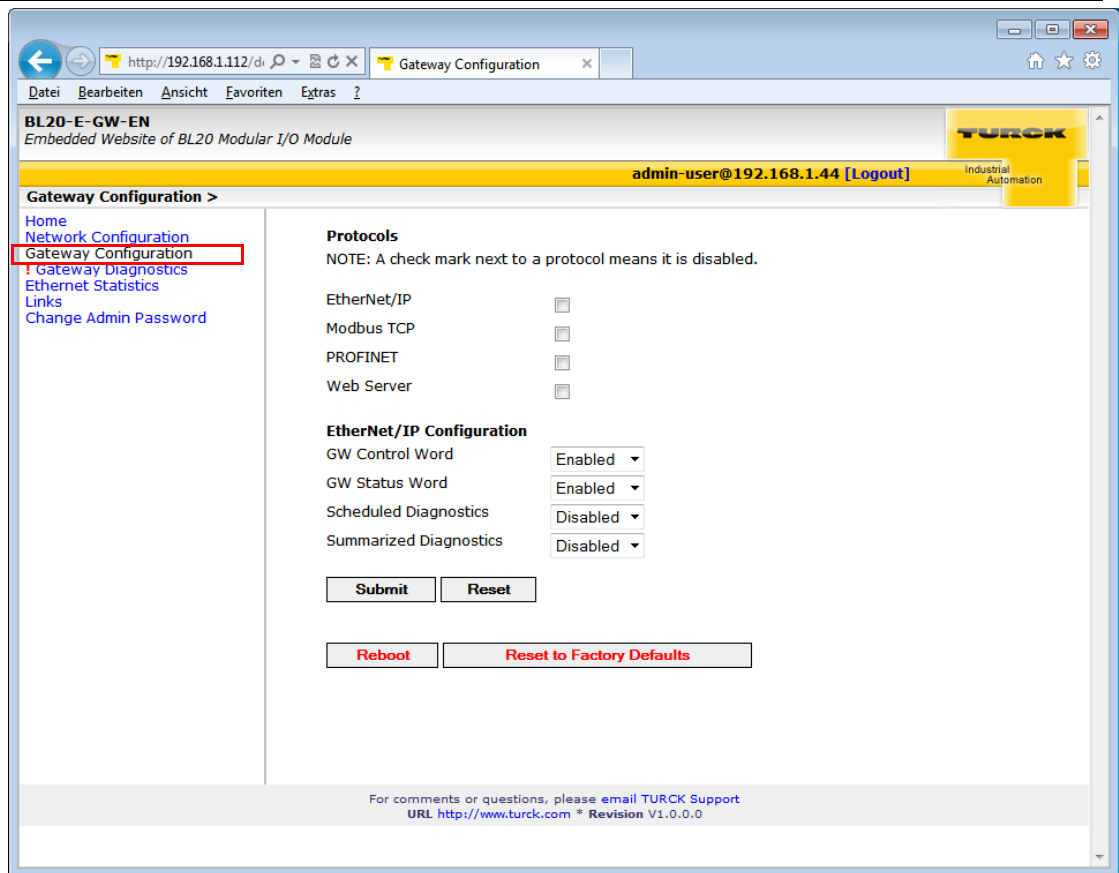

3.7.6 Station Diagnostics

Diagnostic messages of the device are displayed on the "Station Diagnostics"-page.

3.7.7 Ethernet Statistics

The page "Ethernet Statistics" shows information like the port-status, telegram and error counters etc. The page can above all be useful for analyzing network problems.

3.7.8 Links

This page contains for example a link to the product page on the TURCK-homepage.

3.7.9 Change Admin Password

Please define an individual password for administrator rights.

Default password. „password“



Note

A reset of the device to the default-settings using the switch position "F_Reset" also causes a reset of the password to "password".

Figure 3-23:
Change Admin
Password

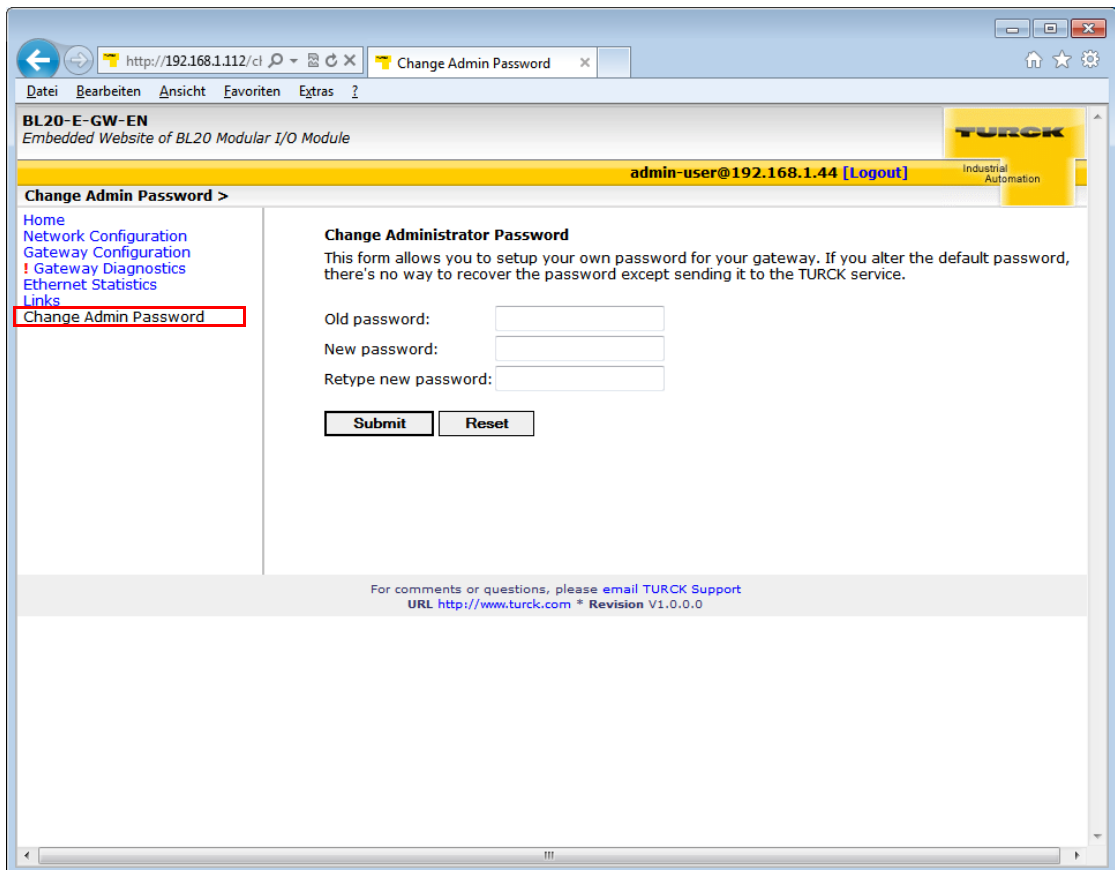

3.8 Status and Control Word of the BL20-stations

The Status as well as the Control Word are mapped into the station's process data.

- EtherNet/IP™
In EtherNet/IP, the mapping can be disabled (see [Gateway Class \(VSC 100, 64h\)](#), and [GW Status Register \(page 4-18\)](#)).
- Modbus TCP → see [Register 0x100C: Gateway status \(page 6-16\)](#)
- PROFINET® → see [Diagnosis in PROFINET® \(page 8-4\)](#)

3.8.1 Status Word

	Byte	Bit 7	Bit 6	Bit 5	Bit 4	Bit 3	Bit 2	Bit 1	Bit 0
Status	0	U _L low	-	-	-	I/O Cfg Warn.	-	-	Diag Warn
	1	-	FCE	-	MB Wdg	I/O CFG	I/O COM	U _{sys} low	U _{sys} high

Meaning of the status bits

Table 3-8:
Meaning of the
status bits

Name	Meaning
Diag Warn	Summarized diagnosis of the device. At least one I/O-module sends active diagnosis.
I/O Cfg Warn.	The station configuration has changed.
U _L low	Load voltage too low (< 18 V DC).
U _{sys} high	System supply voltage too high (> 30 V DC).
U _{sys} low	System supply voltage too low (< 18 V DC).
I/O COM	I/O Communication Lost Error No Communication on the module bus.
I/O CFG	I/O CfgModified Error The I/O-configuration has be changed and is no longer compatible.
MB Wdg	Modbus Watchdogs Error A timeout occurred in the modbus-communication. (only for Modbus TCP)
FCE	Force Mode Active Error The Force Mode is activated, which means, the actual output values may no match the ones defined and sent by the field bus.

3.8.2 Control Word

The Control Word has no function at the moment, it is reserves for further use.

3.9 Parameters of the I/O-modules

3.9.1 Digital input modules

■ BL20-4DI-NAMUR

Table 3-9: Module parameters

	Byte	Bit	Parameter name	Value – Meaning
A default setting	0 to 3	0	input filter x	0 = deactivate – (input filter 0,25 ms) A 1 = activate – (input filter 2,5 ms)
		1	digital input x	0 = normal A 1 = inverted
		2	Short circuit monitoring x	0 = deactivate A 1 = activate
		3	Short circuit diagnosis x	0 = deactivate A 1 = activate
		4	Open circuit monitoring x	0 = deactivate A 1 = activate
		5	Open circuit diagnosis x	0 = deactivate A 1 = activate
		6	Input on diagnostic x	0 = output substitute value A 1 = keep last value
		7	Substitute value on diag x	0 = off A 1 = on

3.9.2 Analog input modules

■ BL20-1AI-I(0/4...20MA)

Table 3-10: Module parameters

	Byte	Bit	Parameter name	Value
A default setting	0	0	current mode	0 = 0...20 mA A
				1 = 4...20 mA
		1	value representation	0 = Integer (15 bit + sign) A 1 = 12 bit (left-justified)
		2	Diagnosis	0 = activate A
				1 = deactivate

■ BL20-2AI-I(0/4...20MA) (1 byte per channel)

<i>Table 3-11: Module parameters</i>		Byte	Bit	Parameter name	Value
A default setting	0/1	0	current mode	0 = 0...20 mA A	
				1 = 4...20 mA	
		1	value representation	0 = Integer (15 bit + sign) A	
				1 = 12 bit (left-justified)	
		2	Diagnosis	0 = activate A	
				1 = deactivate	
		3	Channel	0 = activate A	
				1 = deactivate	

■ BL20-1AI-U(-10/0...+10VDC)

<i>Table 3-12: Module parameters</i>		Byte	Bit	Parameter name	Value
A default setting	0	0	voltage mode	0 = 0...10 V A	
				1 = -10...+10 V	
		1	value representation	0 = Integer (15 bit + sign) A	
				1 = 12 bit (left-justified)	
		2	Diagnosis	0 = activate A	
				1 = deactivate	

■ BL20-2AI-U(-10/0...+10VDC) (1 byte per channel)

<i>Table 3-13: Module parameters</i>		Byte	Bit	Parameter name	Value
A default setting	0/1	0	voltage mode	0 = 0...10 V A	
				1 = -10...+10 V	
		1	value representation	0 = Integer (15 bit + sign) A	
				1 = 12 bit (left-justified)	
		2	Diagnosis	0 = activate A	
				1 = deactivate	
		3	Channel	0 = activate A	
				1 = deactivate	

■ BL20-2AI-PT/NI-2/3 (2 byte per channel)

Table 3-14:
Module parameters

	Byte	Bit	Parameter name	Value
A default setting	0/2	0	Mains suppression	0 = 50 Hz A
				0 = 60 Hz
		1	value representation	0 = Integer (15 bit + sign) A
				1 = 12 bit (left-justified)
		2	Diagnosis	0 = release A
				1 = block
		3	Channel	0 = activate A
				1 = deactivate
	7 to 4		element	0000 = Pt100, -200...850 °C A
				0001 = Pt100, -200...150 °C
0010 = Ni100, -60...250 °C				
0011 = Ni100, -60...150 °C				
0100 = Pt200, -200...850 °C				
0101 = Pt200, -200...150 °C				
0110 = Pt500, -200...850 °C				
0111 = Pt500, -200...150 °C				
1000 = Pt1000, -200...850 °C				
1001 = Pt1000, -200...150 °C				
1010 = Ni1000, -60...250 °C				
1011 = Ni1000, -60...150 °C				
1100 = resistance, 0...100 Ω				
1101 = resistance, 0...200 Ω				
1110 = resistance, 0...400 Ω				
1111 = resistance, 0...1000 Ω				
1/3	0	Measurement mode	0 = 2 wire A	
			1 = 3 wire	

■ BL20-2AI-THERMO-PI (2 byte parameters per channel)

Table 3-15: Module parameters		Byte	Bit	Parameter name	Value
A default setting	0/1	0		Mains suppression	0 = 50 Hz A
					0 = 60 Hz
		1		value representation	0 = Integer (15 bit + sign) A
					1 = 12 bit (left-justified)
		2		Diagnosis	0 = release A
1 = block					
3		Channel	0 = activate A		
			1 = deactivate		
7 to 4		element	0000 = Type K, -270...1370 °C A 0001 = Type B, +100...1820 °C 0010 = Type E, -270...1000 °C 0011 = Type J, -210...1200 °C 0100 = Type N, -270...1300 °C 0101 = Type R, -50...1760 °C 0110 = Type S, -50...1540 °C 0111 = Type T, -270...400 °C 1000 = ±50 mV 1001 = ±100 mV 1010 = ±500 mV 1011 = ±1000 mV ... = reserved		

■ BL20-4AI-U/I (1 byte parameters per channel)

Table 3-16: Module parameters		Byte	Bit	Parameter name	Value
A default setting	0 to 3	0		range	0 = 0...10 V/ 0...20 mA A
					1 = -10...+10 V/ 4...20 mA
		1		value representation	0 = Integer (15 bit + sign) A
					1 = 12 bit (left-justified)
		2		Diagnosis	0 = release A
1 = block					
3		Channel	0 = activate A		
			1 = deactivate		
4		Operation mode	0 = voltage A		
			1 = current		

■ BL20-4AI-U/I (1 byte parameters per channel)

Table 3-17:
Module parameters

Byte	Bit	Parameter name	Value
0 to 3	0	reserved	
	1	value representation	0 = Integer (15 bit + sign) A
			1 = 12 bit (left-justified)
	2	Diagnosis	0 = release A
			1 = block
	3	channel x	0 = activate A
			1 = deactivate
	4	element Kx	0000 = Type K, -270...1370 °C A
			0001 = Type B, +100...1820 °C
			0010 = Type E, -270...1000 °C
			0011 = Type J, -210...1200 °C
			0100 = Type N, -270...1300 °C
0101 = Type R, -50...1760 °C			
0110 = Type S, -50...1540 °C			
0111 = Type T, -270...400 °C			
1000 = ±50 mV			
1001 = ±100 mV			
1010 = ±500 mV			
1011 = ±1000 mV			
1100 = Type K, -454...2498 °F			
1101 = Type J, -346...2192 °F			
1110 = Type C 0... 2315 °C			
1111 = Type G 0... 2315 °C			

■ BL20-2AIH-I

Table 3-18:
Module parameters

	Byte	Bit	Parameter name	Value
A default setting	0 (channel 1)	0	Channel	0 = activate A 1 = deactivate
		1	short circuit diagnostics	0 = block 1 = release A
	2	open circuit diagnostics	0 = block 1 = release A	
	3 + 4	Operation mode	0 = 0...20 mA (polling of HART®-status not possible) 1 = 4...20 mA (polling of HART®-status not possible) 2 = 4...20 mA HART® active A Cyclic polling of HART®-status activated.	
	5 + 6	reserved		
	7	HART®-diagnostics	0 = release A 1 = block	
	1 (channel 1)	0 + 1	value representation	0 = Integer (15 bit + sign) A 1 = NE 43 2 = Extended Range
	2 + 3 (channel 2)		similar to byte 0 + 1	
	4		HART®-Variable A	Defines the channel of which the HART®-variable is read.
		0	channel mapping	0 = channel 1 1 = channel 2
	6 + 7	variable mapping	Defines which HART-variable of the connected sensor is mapped into the module's process data. 0= PV (primary variable) 1= SV (2nd variable) 2 = TV (3rd variable) 3 = QV (4th variable)	

Table 3-18:
Module parameters

Byte	Bit	Parameter name	Value
5	HART®-Variable B		Defines the channel of which the HART®-variable is read.
	0	channel mapping	0 = channel 1 1 = channel 2
	6 + 7	variable mapping	Defines which HART-variable of the connected sensor is mapped into the module's process data. 0= PV (primary variable) 1= SV (2nd variable) 2 = TV (3rd variable) 3 = QV (4th variable)
6	HART®-variable C		Defines the channel of which the HART®-variable is read.
	0	channel mapping	0 = channel 1 1 = channel 2
	6 + 7	variable mapping	Defines which HART-variable of the connected sensor is mapped into the module's process data. 0= PV (primary variable) 1= SV (2nd variable) 2 = TV (3rd variable) 3 = QV (4th variable)
7	HART®-variable D		Defines the channel of which the HART®-variable is read.
	0	channel mapping	0 = channel 1 1 = channel 2
	6 + 7	variable mapping	Defines which HART-variable of the connected sensor is mapped into the module's process data. 0= PV (primary variable) 1= SV (2nd variable) 2 = TV (3rd variable) 3 = QV (4th variable)

■ BL20-E-8AI-U/I-4PT/Ni (1 byte per channel)

Table 3-19:
Module parameters

	Byte	Bit	Parameter name	Value	Meaning
A default setting B In 3-wire measurement, only the first of the used channel has to be parameterized. The parameterization of the second channel is ignored.	0 to 7	0 to 5	Operation mode	000000	voltage, -10...10 V DC Standard A
				000001	voltage ...10 VDC, standard
				000010	voltage, -10...10 VDC, NE 43
				000011	voltage, 0...10 VDC, NE 43
				000100	voltage, -10...10 VDC, Extended Range
				000101	voltage, 0...10 VDC, Extended Range
				000110	reserved
				000111	reserved
				001000	current, 0...20 mA, standard
				001001	current, 4...20 mA, standard
				001010	current, 0...20 mA, NE 43
				001011	current, 4...20 mA, NE 43
				001100	current, 0...20 mA, Extended Range
				001101	current, 4...20 mA, Extended Range
				001110	reserved
				001111	reserved
				010000	Pt 100, -200°C...850 °C, 2-wire
				010001	Pt 100, -200°C...150 °C, 2-wire
				010010	Pt 200, -200°C...850 °C, 2-wire
				010011	Pt 200, -200°C...150 °C, 2-wire
				010100	Pt 500, -200°C...850 °C, 2-wire
				010101	Pt 500, -200°C...150 °C, 2-wire
				010110	Pt 1000, -200°C...850 °C, 2-wire
				010111	Pt 1000, -200°C...150 °C, 2-wire
				011000	Pt 100, -200°C...850 °C, 3-wire B
				011001	Pt 100, -200°C...150 °C, 3-wire B
				011010	Pt 200, -200°C...850 °C, 3-wire B
				011011	Pt 200, -200°C...150 °C, 3-wire B
				011100	Pt 500, -200°C...850 °C, 3-wire B
				011101	Pt 500, -200°C...150 °C, 3-wire B

Table 3-19:
Module parameters

Byte	Bit	Parameter name	Value	Meaning
0 to 7	0 to 5	Operation mode	011110	Pt 1000, -200°C...850 °C, 3-wire B
			011111	Pt 1000, -200°C...150 °C, 3-wire B
			100000	Ni 100, -60 °C...250 °C, 2-wire
			100001	Ni 100, -60°C...150 °C, 2-wire
			100010	Ni 1000, -60 °C...250 °C, 2-wire
			100011	Ni 1000, -60°C...150 °C, 2-wire
			100100	Ni 1000TK5000, -60 °C...250 °C, 2-wire
			100101	reserved
			100110	reserved
			100111	reserved
			101000	Ni 100, -60 °C...250 °C, 3-wire
			101001	Ni 100, -60°C...150 °C, 3-wire
			101010	Ni 1000, -60 °C...250 °C, 3-wire
			101011	Ni 1000, -60°C...150 °C, 3-wire
			101100	Ni 1000TK5000, -60 °C...250 °C, 3-wire
			101101	reserved
			101110	reserved
			101111	reserved
			110000	resistance, 0...250 Ω
			110001	resistance, 0...400 Ω
			110010	resistance, 0...800 Ω
			110011	resistance, 0...2000 Ω
			110100	resistance, 0...4000 Ω
			110101	reserved
111110	reserved			
111111	deactivated			
6		value representation Kx	0	Integer (15 bit + sign) A
			1	12 bit (left-justified)
7		diagnostics Kx	0	release A
			1	block

3.9.3 Analog output modules

■ BL20-1AO-I(0/4...20mA)

<i>Table 3-20: Module parameters</i>		Byte	Bit	Parameter name	Value
A default setting	0	0	current mode	0 = 0...20 mA A	
				1 = 4...20 mA	
	1	value representation	0 = Integer (15 bit + sign) A		
			1 = 12 bit (left-justified)		
	2	reserved to 7			
1	Substitute value low byte				
2	Substitute value high byte				

■ BL20-2AI-I(0/4...20mA) (3 byte per channel)

<i>Table 3-21: Module parameters</i>		Byte	Bit	Parameter name	Value
A default setting	0/3	0	current mode	0 = 0...20 mA A	
				1 = 4...20 mA	
	1	value representation	0 = Integer (15 bit + sign) A		
			1 = 12 bit (left-justified)		
	2	reserved			
	3	Channel	0 = activate A		
1 = deactivate					
4	reserved to 7				
1/4	Substitute value low byte				
2/5	Substitute value high byte				

■ BL20-2AO-U(-10/0...+10VDC) (3 byte per channel)

Table 3-22:
Module parameters

Byte	Bit	Parameter name	Value
0/3	0	voltage mode	0 = 0...10 V A
			1 = -10...+10 V
A default setting	1	value representation	0 = Integer (15 bit + sign) A
			1 = 12 bit (left-justified)
	2	reserved	
	3	Channel	0 = activate A
			1 = deactivate
	4 to 7	reserved	
1/4		Substitute value low byte	
2/5		Substitute value high byte	

■ BL20-2AOH-I

Table 3-23:
Module parameters

Byte	Bit	Parameter name	Value
0 (channel 1)	0	Channel	0 = activate A
			1 = deactivate
	1	Diagnosis	0 = block A
			1 = release
	3 + 4	Operation mode Kx	0 = 0...20 mA (polling of HART®-status not possible)
			1 = 4...20 mA (polling of HART®-status not possible)
			2 = 4...20 mA HART® active A (cyclic polling of HART-status activate)
	7	HART®-diagnostics Kx	0 = release A
			1 = block

Table 3-23:
Module parameters

A default setting

Byte	Bit	Parameter name	Value
1 (channel 1)	0+1	value representation Kx	0 = Integer (15 bit + sign) A 1 = NE 43 2 = Extended Range
	6 + 7	Behavior on module bus error Ax	
	2+3 (channel 1)	substitute value Ax	
4 to 7 (channel 2)	similar to byte 0 to 3		
8	HART®-Variable A		Defines the channel of which the HART®-variable is read.
	0	channel mapping	0 = channel 1 1 = channel 2
	6 + 7	variable mapping	Defines which HART-variable of the connected sensor is mapped into the module's process data. 0= PV (primary variable) 1= SV (2nd variable) 2 = TV (3rd variable) 3 = QV (4th variable)
9	HART®-Variable B		Defines the channel of which the HART®-variable is read.
	0	channel mapping	0 = channel 1 1 = channel 2
	6 + 7	variable mapping	Defines which HART-variable of the connected sensor is mapped into the module's process data. 0= PV (primary variable) 1= SV (2nd variable) 2 = TV (3rd variable) 3 = QV (4th variable)

Table 3-23:
Module parameters

A default setting

Byte	Bit	Parameter name	Value
10		HART®-variable C	Defines the channel of which the HART®-variable is read.
	0	channel mapping	0 = channel 1
			1 = channel 2
6 + 7	variable mapping		Defines which HART-variable of the connected sensor is mapped into the module's process data.
			0= PV (primary variable)
			1= SV (2nd variable)
			2 = TV (3rd variable)
			3 = QV (4th variable)
11		HART®-variable D	Defines the channel of which the HART®-variable is read.
	0	channel mapping	0 = channel 1
			1 = channel 2
6 + 7	variable mapping		Defines which HART-variable of the connected sensor is mapped into the module's process data.
			0= PV (primary variable)
			1= SV (2nd variable)
			2 = TV (3rd variable)
			3 = QV (4th variable)

■ BL20-E-4AO-U/I (3 byte parameters per channel)

Table 3-24:
Module parameters

A default setting

Byte	Bit	Parameter name	Value	Meaning
0/3/6/9	0 to 3	Operation mode Kx	000000	voltage, -10...10 V DC Standard A
			000001	voltage ...10 VDC, standard
			000010	voltage, -10...10 VDC, NE 43
			000011	voltage, 0...10 VDC, NE 43
			000100	voltage, -10...10 VDC, Extended Range
			000101	voltage, 0...10 VDC, Extended Range
			000110	reserved

Table 3-24:
Module parameters

Byte	Bit	Parameter name	Value	Meaning
			000111	reserved
			001000	current, 0...20 mA, standard
			001001	current, 4...20 mA, standard
			001010	current, 0...20 mA, NE 43
			001011	current, 4...20 mA, NE 43
			001100	current, 0...20 mA, Extended Range
			001101	current, 4...20 mA, Extended Range
			001110	reserved
			001111	deactivated
4		value representation Kx	0	Integer (15 bit + sign) A
			1	12 bit (left-justified)
5		diagnostics Kx	0	release A
			1	block
6 + 7		substitute value options	00	output substitute value
			01	hold current value
			10	output min. value
			11	output max. value
1/4/7/ 10		substitute value Ax low byte		
2/5/8/ 11		substitute value Ax high byte		

3.9.4 Technology modules

■ BL20-1RS232

Table 3-25:
Module parameters

	Byte	Bit	Parameter name	Value
A default setting	0	3	Data rate	0000 = 300 bps
		to 0		0001 = 600 bps
				0010 = 1200 bps
				0100 = 2400 bps
				0101 = 4800 bps
				0110 = 9600 bps A
				0111 = 14400 bps
				1000 = 19200 bps
				1001 = 28800 bps
				1010 = 38400 bps
				1011 = 57600 bps
				1100 = 115200 bps
				... reserved
	5, 4		reserved	
	6		DisableReducedCtrl	Constant setting: The diagnostic messages are shown in Byte 6 of the process input data (independently from "Diagnosis"). Byte 6 of the process output data contains 2 bits, with which the receive or transmit buffer can be cleared. Byte 7 contains the status or control byte. User data are represented in Bytes 0 - 5.
	0	7	Diagnosis	0 = release A – Diagnostic activated: This affects the separate fieldbus-specific diagnostic message – not the diagnosis embedded in the process input data.
				1 = block

Table 3-25:
Module parameters

	Byte	Bit	Parameter name	Value
A default setting	1	0	Stop bits	0 = 1 bit A 1 = 2 bit
		2.1	Parity	00 = none 01 = odd A – The parity bit is set so that the total number of bits (data bits plus parity bit) set to 1 is odd. 10 = even – The parity bit is set so that the total number of bits (data bits plus parity bit) set to 1 is odd.
	3		Data bits	0 = 7 A – The number of data bits is 7.
				1 = 8 – The number of data bits is 8.
	1	4 to 5	Flow control	00 = none A – Data flow control is switched off. 01 = XON/XOFF – Software handshake (XON/XOFF) is switched on. 10 = RTS/CTS – Hardware handshake (RTS/CTS) is switched on.
				7.6 reserved
	2		XON character	0 – 255 (17 A) XON character: This character is used to start the transmission of data from the data terminal device if the software handshake is active.
	3		XOFF character	0 – 255 (19 A) XOFF character This character is used to start the transmission of data from the data terminal device if the software handshake is active.

■ BL20-1RS485/422

Table 3-26:
Module parameters

A default setting

Byte	Bit	Parameter name	Value
0	3 to 0	Data rate	0000 = 300 bps
			0001 = 600 bps
			0010 = 1200 bps
			0100 = 2400 bps
			0101 = 4800 bps
			0110 = 9600 bps A
			0111 = 14400 bps
			1000 = 19200 bps
			1001 = 28800 bps
			1010 = 38400 bps
			1011 = 57600 bps
			1100 = 115200 bps
			... reserved
4		Select RS485	0 = parameterization of the module as RS422
			1 = parameterization of the module as RS485
5		reserved	
6		DisableReducedCtrl	Constant setting: The diagnostic messages are shown in Byte 6 of the process input data (independently from "Diagnosis"). Byte 6 of the process output data contains 2 bits, with which the receive or transmit buffer can be cleared. Byte 7 contains the status or control byte. User data are represented in Bytes 0 - 5.
0	7	Diagnosis	0 = release A
			1 = block
1	0	Stop bits	0 = 1 bit A
			1 = 2 bit
2.1		Parity	00 = none
			01 = odd A The parity bit is set so that the total number of bits (data bits plus parity bit) set to 1 is odd.
			10 = even The parity bit is set so that the total number of bits (data bits plus parity bit) set to 1 is odd.
3		Data bits	0 = 7 A The number of data bits is 7.
			0 = 8 A The number of data bits is 8.

Table 3-26:

Module parameters

Byte	Bit	Parameter name	Value
2		XON character	0 – 255 (17 A) only in the RS422-mode: XON character: This character is used to start the transmission of data from the data terminal device if the software handshake is active.
3		XOFF character	0 – 255 (19 A) only in the RS422-mode: XOFF character: This character is used to start the transmission of data from the data terminal device if the software handshake is active.

■ BL20-1SSI

Table 3-27:

Module parameters

A default setting

Byte	Bit	Parameter name	Value – Meaning
0	4 to 0	reserved	
	5	Sensor idle data cable test	0 = activate A ZERO test of data cable. 1 = deactivate After the last valid bit, a ZERO test of the data cable is not carried out.
	7.6	reserved	
1	3 to 0	Number of invalid bits (LSB)	0000 to 1111: Number of invalid bits on the LSB side of the position value supplied by the SSI encoder. The meaningful word width of the position value transferred to the module bus master is as follows: SSI_FRAME_LEN -INVALID_BITS_MSB-INVALID_BITS_LSB. The invalid bits on the LSB side are removed by shifting the position value to the right, starting with the LSB. (Default 0 bit = 0×0). INVALID_BITS_MSB +INVALID_BITS_LSB must always be less than SSI_FRAME_LEN.

Table 3-27:
Module parameters

	Byte	Bit	Parameter name	Value – Meaning
	1	6 to 4	Number of invalid bits (MSB)	000 to 111 Number of invalid bits on the LSB side of the position value supplied by the SSI encoder. The meaningful word width of the position value transferred to the module bus master is as follows: SSI_FRAME_LEN - INVALID_BITS_MSB - INVALID_BITS_LSB. Number of invalid bits on the MSB side of the position value supplied by the SSI encoder. INVALID_BITS_MSB + INVALID_BITS_LSB must always be less than SSI_FRAME_LEN. Default: 0 = 0hex
		7	reserved	
A default setting	2	3 to 0	Data rate	0000 = 1000000 bps 0001 = 500000 bps A 0010 = 250000 bps 0011 = 125000 bps 0100 = 100000 bps 0101 = 83000 bps 0110 = 71000 bps 0111 = 62500 bps ... reserved
		7 to 4	reserved	
	3	5 to 0	Number of data frame bits	00000 to 100000 Number of bits of the SSI data frame. SSI_FRAME_LEN must always be greater than INVALID_BITS. Default: 25 = 19hex
		6	reserved	
		7	Data type	binary coded A SSI encoder sends data in binary code GRAY coded SSI encoder sends data in GRAY code

■ BL20-E-1SWIRE

	Bit 7	Bit 6	Bit 5	Bit 4	Bit 3	Bit 2	Bit 1	Bit 0
Byte 1	reserved	free	free	MC	MNA	configuration	Disable Cfg	free
Byte 2	free	U _{AUXERR}	TYP _{ERR}	TYP _{INFO}	PKZ _{ERR}	PKZ _{INFO}	SD _{ERR}	SD _{INFO}
Byte 3	reserved							
Byte 4	reserved (life guarding time until version VN 01-03)							
Byte 5	SC _{DIAG} S8	SC _{DIAG} S7	SC _{DIAG} S6	SC _{DIAG} S5	SC _{DIAG} S4	SC _{DIAG} S3	SC _{DIAG} S2	SC _{DIAG} S1
Byte 6	SC _{DIAG} S16	SC _{DIAG} S15	SC _{DIAG} S14	SC _{DIAG} S13	SC _{DIAG} S12	SC _{DIAG} S11	SC _{DIAG} S10	SC _{DIAG} S9
Byte 7	reserved							
Byte 8	reserved							
Byte 9 - 24	Type designation slave 1 - 16							

The following table shows the meaning of the parameter bits:

Table 3-28:
Module parameters

Parameter Value name

Byte 1

A default setting

Disable Cfg	If the physical structure of the SWIRE bus does not match the configuration stored in the BL20-E-1SWIRE on power up (SW LED flashing), the physical structure of the SWIRE bus must be stored in the BL20-E-1SWIRE.
0 = inactive A	Manual SWIRE configuration: To store the physical structure of the SWIRE bus in the BL20-E-1SWIRE, the CFG button of the BL20-E-1SWIRE must be pressed manually (only functions if the SW LED is flashing).
1 = active	Automatic SWIRE configuration: If the physical structure of the SWIRE bus does not match the configuration stored in the BL20-E-1SWIRE on power up, the physical structure is stored automatically in the BL20-E-1SWIRE.
configuration	PLC configuration check If the PLC configuration check is activated, the configuration stored in the BL20-E-1SWIRE is compared with the SET configuration stored in the PLC.
0 = active A	The configuration stored in BL20-E-1SWIRE is compared with the SET configuration stored in the PLC. Only SWIRE slaves in the SWIRE bus are accepted that have a device ID completely matching the SET configuration.
1 = inactive	All slaves are mapped in 4Bit INPUT/ 4Bit OUTPUT without checking the device ID.

Table 3-28:
Module parameters

Parameter name	Value	
Byte 1		
MNA active/ passive	Configuration check Bus or slave-oriented configuration check (without function if MC = 1)	
	0 = Bus based A	If the PLC configuration check is activated, data exchange is only started if the configuration stored in the BL20-E-1SWIRE fully matches the SET configuration stored in the PLC. Modifying the bus during operation causes the system to be aborted.
	1 = Slave based	If the PLC configuration check is activated, data exchange is started with all SWIRE slaves that match the SET configuration stored in the PLC. The SWIRE slaves that do not match the SET configuration stored in the PLC do not perform any data exchange.
MC	Moeller conformance (from version VN 01-04) Behavior of the BL20-E-1SWIRE in accordance with SWIRE Conformance criteria.	
	inactive A	Default behavior
	active	The BL20-E-1SWIRE master responds according to the Moeller SWIRE Conformance criteria (see manual for the IO-modules D300717).
SD _{INFO}	Slave error field Activate slave diagnostics info field SD _{ERR} Sx. As soon as a slave on the bus clears its PKZ bit, this is indicated as an individual error depending on the parameter setting.	
	active	Single diagnostics is activated
	inactive	Single diagnostics is not activated
Byte 2		
SD _{ERR}	Group error - slave error Activate slave diagnostics SD _{ERR} Sx. Activate slave diagnostics SDERRSx. As soon as only one slave on the bus sets its error bit, this is indicated as a group error depending on the parameter setting.	
	0 = active A	Group diagnostics is activated
	1 = inactive	Group diagnostics is not activated
PKZ _{INFO}	PKZ error field Activate slave diagnostics info field PKZ _{ERR} Sx. As soon as a slave on the bus clears its PKZ bit, this is indicated as an individual error depending on the parameter setting.	
	0 = active A	Single diagnostics is activated
	1 = inactive	Single diagnostics is not activated

Table 3-28:
Module parameters

Parameter name	Value
Byte 2	
PKZ _{ERR}	Group PKZ error field Activate slave diagnostics PKZ _{ERR} . As soon as a slave on the bus clears its PKZ bit, this is indicated as an individual error depending on the parameter setting.
0 = active A	Group diagnostics is activated
1 = inactive	Group diagnostics is not activated
TYP _{INFO}	Configuration error field As soon as a slave on the bus does not match the set configuration and therefore cannot be started, this is indicated as an individual error depending on the parameter set.
0 = active A	Single diagnostics is activated
1 = inactive	Single diagnostics is not activated
TYP _{ERR}	Group configuration error field Activate slave diagnostics TYP _{ERR} Sx. As soon as only one slave on the bus is incorrectly configured, this is indicated as an error depending on the parameter setting.
0 = active A	Group diagnostics is activated
1 = inactive	Group diagnostics is not activated
Byte 2	
U _{AUXERR}	Error message Voltage U _{AUX} - Activate system diagnostics U _{AUXERR} . U _{AUXERR} will generate an error message as soon as the power supply goes below a level at which the function of the relays is not guaranteed.
0 = active A	Error message U _{AUXERR} activated
1 = inactive	Error message U _{AUXERR} not activated
Byte 3	reserved
Byte 4	
reserved (Lifeguarding time only up to version VN01-03)	Was up to version VN 01-03: Lifeguarding time of the SWIRE slaves. Lifeguarding time of the SWIRE slaves
0x02-0xFF	Lifeguarding time of the SWIRE slaves
0x64 A	Setting of lifeguarding time of SWIRE slaves, timeout time up to automatic reset of the slaves in the event of communication failure. (n * 10ms) (Default 1s)
0xFF: 0xFF	Lifeguarding off

Table 3-28:
Module parameters

Parameter name	Value
Byte 5 - 6	
SD _{DIAG} Sx	Input bit communication error, slave x Slave diagnostics message from Byte 1 / Bit 7 is accepted in the feedback interface as Bit 4
0 = active A	SD _{DIAG} Sx is accepted
1 = inactive	SD _{DIAG} Sx is not accepted
Byte 7 - 8	reserved
Byte 9 to 24	
Device ID, slave x	TYPE setting for the LIN slave at position x on the SWIRE bus
	0x20 SWIRE-DIL-MTB (: 0xFF)
	0xFF Basic setting (no slave)

- BL20-E-2CNT-2PWM (see separate manual for the module, [D301224](#), „BL20 – I/O-MODULES BL20-E-2CNT-2PWM“, chapter 2)
- BL20-2RFID-S (see RFID-documentation www.turck.de)

3.10 Diagnostic messages of the modules

3.10.1 Power distribution modules

■ BL20-BR-24VDC-D

Table 3-29:
BL20-BR-
24VDC-D

Diagnostic byte	Bit	Diagnosis
n	0	Module bus voltage warning
	1	reserved
	2	Undervoltage field supply
	3	reserved

■ BL20-PF-24VDC

Table 3-30:
BL20-PF-24VDC

Diagnostic byte	Bit	Diagnosis
n	0	reserved
	1	reserved
	2	Undervoltage field supply
		reserved

■ BL20-PF-120/230VAC-D

Table 3-31:
BL20-PF-120/
230VAC-D

Diagnostic byte	Bit	Diagnosis
n	0	reserved
	1	reserved
	2	Undervoltage field supply
		reserved

3.10.2 Digital input modules

■ BL20-4DI-NAMUR

Table 3-32:
BL20-4DI-
NAMUR

Diagnostic byte	Bit	Diagnosis
n	0	short circuit sensor 1
	1	open circuit sensor 1
	2	short circuit sensor 2
	3	open circuit sensor 2
	4	short circuit sensor 3
	5	open circuit sensor 3
	6	short circuit sensor 4
	7	open circuit sensor 4

3.10.3 Analog input modules

■ BL20-1AI-I(0/4...20MA)

Table 3-33:
BL20-1AI-I(0/
4...20MA)

Diagnostic byte	Bit	Diagnosis
n (channel 1)	0	measurement value range error A
	1	Open circuit

■ BL20-2AI-I(0/4...20MA)

Table 3-34:
BL20-2AI-I(0/
4...20MA)

Diagnostic byte	Bit	Diagnosis
n (channel 1)	0	measurement value range error A
	1	Open circuit
n + 1 (channel 2)	0	measurement value range error A
	1	Open circuit

■ BL20-1AI-U(-10/0...+10VDC)

Table 3-35:
BL20-1AI-U
(-10/0...10VDC)

Diagnostic byte	Bit	Diagnosis
n (channel 1)	0	Measurement value range error

■ BL20-2AI-U(-10/0...+10VDC)

Table 3-36:
BL20-2AI-U
(-10/0...10VDC)

Diagnostic byte	Bit	Diagnosis
n (channel 1)	0	Measurement value range error
n (channel 2)	0	Measurement value range error

■ BL20-2AI-PT/NI-2/3

Table 3-37:
BL20-2AI-PT/NI-
2/3

Diagnostic byte	Bit	Diagnosis	
A threshold: 1 % of the positive measurement range end value	n (channel 1)	0	measurement value range error A (Underflow diagnostics in temperature measurement ranges only)
		1	Open circuit
		2	Short circuit B (in temperature measurement ranges only)
B threshold: 5 Ω (loop resistance)		3 to 7	

■ BL20-2AI-THERMO-PI

Table 3-38:
BL20-2AI-
THERMO-PI

Diagnostic byte	Bit	Diagnosis	
A threshold: 1 % of the positive measurement range end value	n	0	measurement value range error A
		1	Open circuit (in temperature measurement ranges only)
		2 to 7	reserved

■ BL20-2AIH-I

Table 3-39:
BL20-2AIH-I

Diagnostic byte	Bit	Diagnosis
n	0	overflow The measurement value exceeds the value ranges and the device is not able to capture these values.
	1	Open circuit Displays an open circuit in the signal line.
	2	Short circuit Displays a short circuit in the signal line.
	3	undervoltage The measurement value is below the value ranges and the device is not able to capture these values.
	4	HART® status-error The connected HART®-device set a bit in the HART® status-information ("status - polling").
	5	HART® communication error The channel does not allow communication with the HART®-device.
	6	Invalid parameter
	7	Hardware error Shows common errors of the module hardware. The return analog value in case of an error is "0".

■ BL20-4AI-U/I

Table 3-40:
BL20-4AI-U/I

Diagnostic byte	Bit	Diagnosis
A threshold: 1% of the positive measurement range end value, underflow diagnostics only in value range 4...20 mA B threshold: 3 mA (only in value range 4...20 mA)	n (channel 0)	0 measurement value range error A
	to n + 3 (channel 3)	1 open circuit B
		2 to 7 reserved

■ BL20-E-8AI-U/I-4AI-PT/NI

Table 3-41:
BL20-E-8AI-U/I-
4AI-PT/NI

	Diagnostic byte	Bit	Diagnosis
A thresholds: value represen- tation of the module in man- ual D300716	n (channel 0) to n + 7 (channel 7)	0	Measurement value range error (OoR) A
		1	Wire break (WB) A
		2	Short circuit (SC) A
		3	Overflow/ underflow (OUFL) A
		4 to 6	reserved
		7	Hardware error

3.10.4 Digital output modules

■ BL20-2DO-24VDC-0.5A-P

Table 3-42:
BL20-2DO-
24VDC-0.5A-P

	Diagnostic byte	Bit	Diagnosis
n		0	overcurrent (short-circuit channel 1)
		1	overcurrent (short-circuit channel 2)

■ BL20-2DO-24VDC-0.5A-N

Table 3-43:
BL20-2DO-
24VDC-0.5A-N

	Diagnostic byte	Bit	Diagnosis
n		0	overcurrent (short-circuit channel 1)
		1	overcurrent (short-circuit channel 2)

■ BL20-2DO-24VDC-2A-P

Table 3-44:
BL20-2DO-
24VDC-2A-P

	Diagnostic byte	Bit	Diagnosis
n		0	overcurrent (short-circuit channel 1)
		1	overcurrent (short-circuit channel 2)

■ BL20-4DO-24VDC-0.5A-P

Table 3-45:
BL20-4DO-
24VDC-0.5A-P

Diagnostic byte	Bit	Diagnosis
n	0	overcurrent /short-circuit (1 ch. min)

■ BL20-16DO-24VDC-0.5A-P

Table 3-46:
BL20-16DO-
24VDC-0.5A-P

Diagnostic byte	Bit	Diagnosis
n	0	Overcurrent (short-circuit channel 1-4)
	1	Overcurrent (short-circuit channel 5-8)
	2	Overcurrent (short-circuit channel 9-12)
	3	Overcurrent (short-circuit channel 13-16)

■ BL20-32DO-24VDC-0.5A-P

Table 3-47:
BL20-32DO-
24VDC-0.5A-P

Diagnostic byte	Bit	Diagnosis
n	0	Overcurrent (short-circuit channel 1-4)
	1	Overcurrent (short-circuit channel 5-8)
	2	Overcurrent (short-circuit channel 9-12)
	3	Overcurrent (short-circuit channel 13-16)
	4	Overcurrent (short-circuit channel 17-20)
	5	Overcurrent (short-circuit channel 21-24)
	6	Overcurrent (short-circuit channel 25-28)
	7	Overcurrent (short-circuit channel 29-32)

3.10.5 Analog output modules

■ BL20-2AOH-I

Table 3-48:
BL20-2AOH-I

Diagnostic byte	Bit	Diagnosis
n	0	Value above upper limit Display of a measurement range exceeding → limit values according to parameterization
	1	Open circuit Displays an open circuit in the signal line.
	2	invalid value The output value exceeds the values which the module is able to interpret.
	3	value below lower limit Display of a measurement range underflow → limit values according to parameterization
	4	HART® status error The connected HART®-device set a bit in the HART® status-information ("status - polling").
	5	HART® communication error The channel does not allow communication with the HART®-device.
	6	Invalid parameter
	7	Hardware error Shows common errors of the module hardware. The return analog value in case of an error is "0".

■ BL20-E-4AO-U/I

Table 3-49:
BL20-E-4AO-U/I

Diagnostic byte	Bit	Diagnosis
A thresholds: value representation of the module in manual D300716	n (channel 0)	0 Measurement value range error (OoR) A
	n + 3 (channel 3)	1 reserved
		2 reserved
	n + 3 (channel 3)	3 Overflow/ underflow (OUFL) A
		4 to 6 reserved
		7 Hardware error

3.10.6 Technology modules

■ BL20-1CNT-24VDC

Table 3-50:
BL20-1CNT-
24VDC

Diagnostic byte	Bit	Diagnosis
n	0	Short-circuit / open circuit DO → ERR_DO
if bit 7=0 (counter mode)	1	Short-circuit in sensor power supply, 24 V DC → ERR-24VDC
	2	End of counter range wrong
	3	Start of counter range wrong
	4	Invert-DI+latch-retr. not perm. It is not permitted to invert the level of the digital input when using the latch-retrigger-function
	5	Main count direction wrong
	6	Operating mode wrong
	7	Measurement mode Bit = 0 Counter mode active
n	0	Short-circuit / open circuit DO → ERR_DO
If bit 7 = 0 (measurement mode)	1	Short-circuit in sensor power supply, 24 V DC → ERR-24VDC
	2	Sensor pulse wrong
	3	Integration time wrong
	4	Upper limit wrong
	5	Lower limit wrong
	6	Operating mode wrong
	7	Measurement mode Bit = 1 measurement operation is active

■ BL20-1RS232

Table 3-51:
BL20-1RS232

Diagnostic byte	Bit	Diagnosis
n	0	parameterization error
	1	Hardware failure
	2	Data flow control error
	3	frame error
	4	buffer overflow

■ BL20-1RS485/422

Table 3-52:
BL20-1RS485/
422

Diagnostic byte	Bit	Diagnosis
n	0	parameterization error
	1	Hardware failure
	2	Data flow control error (only in the RS422-mode)
	3	frame error
	4	buffer overflow

■ BL20-1SSI

Table 3-53:
BL20-1SSI

Diagnostic byte	Bit	Diagnosis
n	0	SSI group diagnostics
	1	Open circuit
	2	sensor value overflow
	3	sensor value underflow
	4	parameterization error

■ BL20-E-1SWIRE

	Bit 7	Bit 6	Bit 5	Bit 4	Bit 3	Bit 2	Bit 1	Bit 0
Byte n	GENERAL_ERR	U_SWERR	free	COM_ERR	free	RDY_ERR	free	SW_ERR
Byte n+1	free	U_AUXERR	TYP_ERR	free	PKZ_ERR	free	SD_ERR	free
TYP_ERR field								
Byte n+2	TYP_ERR_S8	TYP_ERR_S7	TYP_ERR_S6	TYP_ERR_S5	TYP_ERR_S4	TYP_ERR_S3	TYP_ERR_S2	TYP_ERR_S1
Byte n+3	TYP_ERR_S16	TYP_ERR_S15	TYP_ERR_S14	TYP_ERR_S13	TYP_ERR_S12	TYP_ERR_S11	TYP_ERR_S10	TYP_ERR_S9
Slave diagnosis								
Byte n+4	SD_ERR_S8	SD_ERR_S7	SD_ERR_S6	SD_ERR_S5	SD_ERR_S4	SD_ERR_S3	SD_ERR_S2	SD_ERR_S1
Byte n+5	SD_ERR_S16	SD_ERR_S15	SD_ERR_S14	SD_ERR_S13	SD_ERR_S12	SD_ERR_S11	SD_ERR_S10	SD_ERR_S9
PKZ field								
Byte n+6	PKZ_ERR_S8	PKZ_ERR_S7	PKZ_ERR_S6	PKZ_ERR_S5	PKZ_ERR_S4	PKZ_ERR_S3	PKZ_ERR_S2	PKZ_ERR_S1
Byte n+7	PKZ_ERR_S16	PKZ_ERR_S15	PKZ_ERR_S14	PKZ_ERR_S13	PKZ_ERR_S12	PKZ_ERR_S11	PKZ_ERR_S10	PKZ_ERR_S9

The following table shows the meaning of the diagnostic bits:

Table 3-54:
Meaning of the
diagnostic bits

Designation	Value	Meaning
Byte 1		
SW _{ERR}	SWIRE MASTER	
	If the physical structure of the SWIRE bus does not match the configuration stored in the BL20-E-1SWIRE, this bit indicates an error.	
	0	Data exchange The physical structure of the SWIRE bus was accepted and the SWIRE bus is in operation.
1	Offline The physical structure was not accepted, the SWIRE bus does not start operation (SW LED flashing).	
RDY _{ERR}	SPS SLAVE	
	This bit indicates an error if the configuration stored in the BL20-E-1SWIRE does not match the SET configuration stored in the PLC.	
	0	Data exchange No error present. The SWIRE bus is ready for data exchange.
1	Offline The configuration stored in the BL20-E-1SWIRE was not accepted. The data exchange is prevented (RDY LED flashing).	
COM _{ERR}	Communication SWIRE	
	A communication error is present, such as a slave is no longer reached, its internal timeout has elapsed or communication is faulty. The master cannot carry out data exchange with at least one slave.	
	0	OK No error present.
1	faulty An error is present.	
U _{SWERR}	Voltage U _{SW}	
	Voltage fault in U _{SW} , voltage (17 VDC) for supplying the SWIRE slaves	
	0	OK No error present.
1	under voltage An error is present.	
GENERAL _{ERR}	Error message	
	The creation of a function block shows that systems/function blocks for the general checking of a slave for any diagnostics messages present only check the first byte.	
	0	none No diagnostics message present
1	present One/several diagnostics messages present	

Table 3-54:
Meaning of the
diagnostic bits

Designation	Value	Meaning
Byte 2		
SD _{ERR}	Communication SWIRE slave	
	If the parameter SD _{ERR} A is set for group diagnostics, this bit indicates an error as soon as only one slave on the bus sets its SD _{ERR} .	
	0	OK No error is present or diagnostics function has been deactivated via the parameter setting.
1	faulty An error is present.	
PKZ _{ERR}	Overcurrent protective circuit-breaker	
	If the parameter PKZ _{ERR} A is set for group diagnostics, this bit indicates an error as soon as only one PKZ of a slave has tripped.	
	0	OK No PKZ error is present or diagnostics function has been deactivated via the parameter setting.
1	Tripping At least one PKZ has tripped.	
TYP _{ERR}	configuration	
	If the TYP _{ERR} parameter is set with group diagnostics in the parameter setting, this bit indicates an error as soon as a PLC configuration check detects differing slave numbers, types or position of an SWIRE slave.	
	0	OK The PLC configuration check was positive (the configuration stored in the BL20-E-1SWIRE matches the SET configuration stored in the PLC) or the diagnostics function is deactivated via the parameter setting.
1	faulty A mismatch was determined in the PLC configuration check.	
U _{AUXERR}	Voltage U _{AUX}	
	If the U _{AUXERR} A parameter is activated, U _{AUXERR} will generate an error message as soon as the power supply goes below the level at which the function of the relays is not guaranteed.	
	0	OK Contactor supply voltage is o.k. (> 20 VDC) or diagnostics function has been deactivated via this parameter.
1	under voltage Contactor supply voltage is not o.k. (< 18 VDC).	

Table 3-54:
Meaning of the
diagnostic bits

Designation Value Meaning

Byte 3.4

TYP _{ERR} Sx	Device configuration, slave x	
Info field for the individual indication of a configuration error as error message. Info field for the individual indication of a configuration error as error message. If the TYP _{INFO} parameter is set with individual diagnostics, the error is indicated in this bit field as soon as a PLC configuration check detects differing slave numbers, types or position of an SWIRE slave.		
0	OK	No configuration error is present and the slave is in data exchange mode or diagnostics function has been deactivated via the parameter setting.
1	incorrect	Configuration error present and the slave is NOT in data exchange mode.

Byte 5.6

SD _{ERR} Sx	Communication, slave x	
Info field for the individual indication of the release of the slave diagnostics as error message. If the SD _{INFO} A is set for single diagnostics, this bit field indicates the error as soon as the slave diagnostic message of the slave Sx is triggered.		
0	OK	No error is present or diagnostics function has been deactivated via the parameter setting.
1	Offline	A diagnostics message is present.

Byte 7.8

PKZ _{ERR} Sx	Overcurrent protective circuit-breaker, slave x	
Info field for the individual indication of the tripping a motor-protective circuit-breaker (PKZ) as error message. If the PKZ _{INFO} A is set for single diagnostics, this bit field indicates the error as soon as the PKZ of the slave Sx has tripped.		
0	OK	The PKZ of the slave has not tripped or diagnostics function has been deactivated via the parameter setting.
1	tripped	The PKZ of the slave has tripped



Note

The error messages U_{AUXERR}, TYP_{ERR}, TYP_{ERR}Sx, PKZ_{ERR}, PKZ_{ERR}Sx, SD_{ERR} and SD_{ERR}Sx can be deactivated by a respective parameterization.

- BL20-E-2CNT-2PWM (see separate manual for this module [D301224](#))
- BL20-2RFID-S (see RFID-documentation www.turck.de)

4 Implementation of EtherNet/IP™

4.1	Diagnostic messages via the process data	4-2
4.1.1	Summarized Diagnostics.....	4-2
4.1.2	Scheduled Diagnostics.....	4-2
4.2	Classes and Instances of the EtherNet/IP™-stations	4-3
4.2.1	EtherNet/IP™ Standard Classes	4-3
4.2.2	Identity Object (0x01)	4-4
4.2.3	Assembly Object (0x04)	4-6
	– Process data instances	4-7
	– Mapping of process data.....	4-8
4.2.4	Connection Manager Object (0x06)	4-9
4.2.5	TCP/IP Interface Object (0xF5).....	4-10
4.2.6	Ethernet Link Object (0xF6)	4-14
4.3	VSC-Vendor Specific Classes	4-16
4.3.1	Class Instance of the VSCs.....	4-16
4.3.2	Gateway Class (VSC 100, 64h)	4-17
	– Class instance	4-17
	– Object Instance 1.....	4-17
	– Object Instance 2.....	4-18
4.3.3	Process Data Class (VSC102, 66h)	4-20
	– Class instance	4-20
	– Object instance 1, standard input process data (compressed)	4-20
	– Object Instance 3, diagnostic instance	4-21
	– Object Instance 4, COS/CYCLIC instance.....	4-21
4.3.4	Miscellaneous Parameters Class (VSC 126).....	4-22
	– Instance 1 (port 1)/ Instance 2 (port 2)	4-22

4.1 Diagnostic messages via the process data

Besides the evaluation of diagnostic data via Explicit Messages, BL20 with EtherNet/IP™ offers the possibility of mapping diagnostic data into the process data (see also the stations' process data mappings (page 4-8 ff.).

2 different forms of diagnostic data handling are provided:

- summarized diagnostics
- Scheduled Diagnostics

4.1.1 Summarized Diagnostics

The summarized diagnostic data mode will send back 1 bit for each slice within the station.

This bit will be "0" if there are no diagnostic flags set on the slice. If there are any diagnostic events on the device, the bit will be set to "1".

The diagnostic bits are placed at the end of the input data. The diagnostic data start WORD aligned (see page 4-8).

Bit „I/O Diag Warn“

0 = OK, no diagnostics present

at least one module sends diagnostics (acc. to VSC 100, Gateway Class, Attr. 116, page 4-17)

4.1.2 Scheduled Diagnostics

If scheduled diagnostics is activated (Process Data Class (VSC102, 66h) (page 4-20)), the manufacturer specific diagnostic bits are mapped into the station's process data (page 4-2 ff.).

The scheduled diagnostic data is placed at the end of the input data and after the summarized diagnostic data (see page 4-8).

The scheduled diagnostic data is a time sliced module related data block, which holds diagnostic data of all modules with active diagnostics using a round robin mechanism.

This diagnostic "window" visualizes a specific module diagnostic data for approx. 125 ms and changes over to the next active diagnostics afterwards. This is done automatically by the gateway.

The data length for the scheduled diagnostics is set according to properties of the modules attached to the gateway.

word-	Byte	Data
0	0	slot-no. of the module which sends an emergency-frame.
	1	Status process release: bit 5 = 1: diagnostic active bit 6 = 1: wrong module bit 7 = 1 Module pulled (acc. to VSC 100, Gateway Class, Attr. 116, page 4-17)
n		Module diagnostics from the module actually referenced by the roundrobin mechanism.

4.2 Classes and Instances of the EtherNet/IP™-stations

4.2.1 EtherNet/IP™ Standard Classes

The BL20-stations support the following EtherNet/IP™ Standard Classes in accordance with the CIP specification.

<i>Table 4-1: EtherNet/IP™ Standard Classes</i>	Class Code	Object name
	01 (0x01)	Identity Object (0x01)
	04 (0x04)	Assembly Object (0x04)
	06 (0x06)	Connection Manager Object (0x06)
	245 (0xF5)	TCP/IP Interface Object (0xF5)
	246 (0xF6)	Ethernet Link Object (0xF6)

4.2.2 Identity Object (0x01)

The following description of the Ethernet Link Object is taken from the CIP specification, Vol. 2, Rev. 2.1 by ODVA & ControlNet International Ltd. and adapted to BL20.

Class Attributes

*Table 4-2:
Class Attributes*

Attr. No.	Attribute name	Get/ Set	Type	Value
1 (0x01)	REVISION	G	UINT	1
2 (0x02)	MAX OBJECT INSTANCE	G	UINT	1
6 (0x06)	MAX CLASS ATTRIBUTE	G	UINT	7
7 (0x07)	MAX INSTANCE ATTRIBUTE	G	UINT	7

Object-instance 1 - instance attributes

*Table 4-3:
Instance attributes, object-instance 1*

Attr. No.	Attribute name	Get/ Set	Type	Description
1 (0x01)	VENDOR	G	UINT	Contains the vendor ID. TURCK = 48
2 (0x02)	PRODUCT TYPE	G	UINT	Indicates the general type of product. Communications Adapter 12 _{dez} = 0x0C
3 (0x03)	PRODUCT CODE	G	UINT	Identifies a particular product within a device type. Default: 27247 _{dec} = 6A6F
4 (0x04)	REVISION Major Minor	G	STRUCT OF: USINT USINT	Revision of the item the Identity Object is representing. 0x01 0x06
5 (0x05)	DEVICE STATUS	G	WORD	see Table 4-4: Device Status
6 (0x06)	SERIAL NUMBER	G	UDINT	Contains the ident-no. of the product (3 last bytes of the MAC-ID).
7 (0x07)	PRODUCT NAME LENGTH NAME	G	STRUCT OF: USINT STRING [13]	

Device Status

Table 4-4:
Device Status

Bit	Name	Definition
0 to 1	reserved	Default = 0
2	Configured	TRUE = 1 → The application of the device has been configured (≠ default-settings).
3	reserved	Default = 0
4 to 7	Extended Device Status	0011 = no I/O connection established 0110 = At least one I/O connection in run mode 0111 = At least one I/O connection established, all in IDLE mode All other settings = reserved
8 to 15	reserved	Default = 0

Common Services

Table 4-5:
Common services

Service code	Class	Instance	Service name
01 (0x01)	yes	yes	Get_Attribute_All Returns a predefined list of the object's attributes.
05 (0x05)	no	yes	Reset Starts the reset service for the device.
14 (0x0E)	yes	yes	Get_Attribute_Single Returns the contents of a specified attribute.
16 (0x10)	no	no	Set_Attribute_Single Modifies a single attribute.

4.2.3 Assembly Object (0x04)

Assembly Objects bind attributes of multiple objects to allow data to or from each object to be sent or received over a single connection.

The following description of the Ethernet Link Object is taken from the CIP specification, Vol. 2, Rev. 2.1 by ODVA & ControlNet International Ltd. and adapted to BL20.

Class Attributes

Table 4-6:
Class Attributes

Attr. No.	Attribute name	Get/ Set	Type	Value
1 (0x01)	REVISION	G	UINT	2
2 (0x02)	MAX OBJECT INSTANCE	G	UINT	104

Instance Attributes

Table 4-7:
Instance
attribute

Attr. No.	Attribute name	Get/ Set	Type	Description
3 (0x03)	DATA	S	ARRAY OF BYTE	
4 (0x04)	SIZE	G	UINT	UINT Number of bytes in attr. 3 256 or variable

Common Services

Table 4-8:
Common ser-
vices

Service code	Class	Instance	Service name
01 (0x01)	yes	yes	Get_Attribute_All
14 (0x0E)	no	yes	Get_Attribute_Single

Process data instances

Instance 101

Contains the station's input data (static length 256 bytes).

2 Bytes status information (see [page 3-28](#))

+ process data

Instance 102

Contains the station's output data (static length 256 bytes).

2 Bytes Control data (mapped, but not defined)

+ process data

Instance 103 und Instance 104

In- and output assembly instances with variable assembly sizes. The assembly size is pre-calculated to support the stations I/O-configuration, enabled diagnostics, etc.

- input assembly instance: 103
- output assembly instance: 104

The effective size of the Assembly Instance can be determined using the Assembly Object (instance 0x67, attribute 0x04) and can be from 2 to 496 bytes large.

Mapping of process data

The process data image of the BL20-gateways is depicted in WORD-format (16 bit).

The process data of successive modules of the same type, with process data of less than 1 word, are grouped together until 16 bits of process data is reached.

The process data is written in a new word when:

- 16-bit input data is reached and further input modules follow
- 16-bit output data is reached and further output modules follow
- An input module, whose process data length cannot be completely incorporated in the preceding word, follows on from another input module
- An output module, whose process data length cannot be completely incorporated in the preceding word, follows on from another output module

Table 4-9:
Data mapping
for
BL20-E-GW-EN

Produced Data (word no.)	Input data
0	Status Word of the gateway Mapping can be disabled using attr. 138 in VSC100, object instance 2, page 4-17)
1 to n	Input data of modules An example mapping can be found in chapter 5, I/O data mapping (page 5-9) .
n + x	Summarized diagnostic data (page 4-2) of individual length (1 bit per module which sends diagnostics). Can be enabled/disabled using VSC102, Object instance 3, attr. 104, page 4-20 ff. (x = the no. of following bytes depending on the no. of slices within the station)
n + y	Scheduled diagnostic data (page 4-2).. Can be enabled/disabled using VSC102, Object instance 3, attr. 105, page 4-20 ff. (y = data length for the scheduled diagnostics set according to the properties of the modules attached to the gateway)
Consumed Data (word no.)	Output data
0	Control word of the gateway. The mapping can be disabled using attribute 139 "GW CONTROL REGISTER" in the Gateway Class (VSC 100), object instance 2 (see page 4-19).
1- n	Output data of modules An example mapping can be found in chapter 5, I/O data mapping (page 5-9) .



Note

The data mapping can be structured individually. All parts except for the in- and out-put data of the station can be enabled/ disabled independently from each other.

4.2.4 Connection Manager Object (0x06)

This object is used for connection and connectionless communications, including establishing connections across multiple subnets.

The following description of the Ethernet Link Object is taken from the CIP specification, Vol. 2, Rev. 2.1 by ODVA & ControlNet International Ltd. and adapted to BL20.

Common Services

*Table 4-10:
Common services*

Service code	Class	Instance	Service name
84 (0x54)	no	yes	FWD_OPEN_CMD (Opens a connection)
78 (0x4E)	no	yes	FWD_CLOSE_CMD (Closes a connection)
82 (0x52)	no	yes	UNCONNECTED_SEND_CMD

4.2.5 TCP/IP Interface Object (0xF5)

The following description of the Ethernet Link Object is taken from the CIP specification, Vol. 2, Rev. 1.1 by ODVA & ControlNet International Ltd. and adapted to BL20.

Class Attributes

Table 4-11: Class Attributes

Attr. No.	Attribute name	Get/Set	Type	Value
1 (0x01)	REVISION	G	UINT	1
2 (0x02)	MAX OBJECT INSTANCE	G	UINT	1
3 (0x03)	NUMBER OF INSTANCES	G	UINT	1
6 (0x06)	MAX CLASS IDENTIFIER	G	UINT	7
7 (0x07)	MAX INSTANCE ATTRIBUTE	G	UINT	6

Object instance 1: instance attribute

Table 4-12: Instance attributes, object-instance 1

Attr. No.	Attribute name	Get/Set	Type	Description
1 (0x01)	STATUS	G	DWORD	Interface status (see page 4-11 , Table 4-14: Interface Status)
2 (0x02)	CONFIGURATION CAPABILITY	G	DWORD	Interface Capability Flag (see page 4-11 , Table 4-15: Configuration Capability)
3 (0x03)	CONFIGURATION CONTROL	G/S	DWORD	Interface Control Flag (see page 4-12 , Table 4-16: Configuration Control)
4 (0x04)	PHYSICAL LINK OBJECT	G	STRUCT	
	Path size		UINT	Number of 16bit words: 0x02
	path		Padded EPATH	0x20, 0xF6, 0x24, 0x01
5 (0x05)	INTERFACE CONFIGURATION	G	Structure of:	TCP/IP Network Interface Configuration (see page 4-12)
	IP address	G	UDINT	Current IP address
	NETWORK MASK	G	UDINT	Current network mask
	GATEWAY ADDR.	G	UDINT	Current default gateway
	NAME SERVER	G	UDINT	0 = no name server address configured
	NAME SERVER 2		UDINT	0 = no secondary name server address configured
	DOMAIN NAME	G	UDINT	0 = no Domain Name configured
6 (0x06)	HOST NAME	G	STRING	0 = no Host Name configured (see page 4-12)
12 (0x0C)	Quick Connect	G/S	BOOL	0 = deactivate 1 = activate

Common ServicesTable 4-13:
Common services

Service code	Class	Instance	Service name
01 (0x01)	yes	yes	Get_Attribute_All
02 (0x02)	no	no	Set_Attribute_All
14 (0x0E)	yes	yes	Get_Attribute_Single
16 (0x10)	no	yes	Set_Attribute_Single

■ **Interface Status**

The Status attribute indicates the status of the TCP/IP network interface.

Refer to the state diagram, [Figure 4-1: TCP/IP object state diagram \(acc. to CIP Spec., Vol.2, Rev. 1.1\)](#) for a description of object states as they relate to the Status attribute.

Table 4-14:
Interface Status

Bit(s)	Name	Definition
0-3	Interface Configuration Status	Indicates the status of the Interface Configuration attribute: 0 = The Interface Configuration attribute has not been configured 1 = The Interface Configuration attribute contains valid configuration. 2 to 15: reserved
4 to 31	reserved	

■ **Configuration Capability**

The Configuration Capability indicates the device's support for optional network configuration capability.

Table 4-15:
Configuration Capability

Bit(s)	Name	Definition	Value
0	BOOTP Client	The device is capable of obtaining its network configuration via BOOTP.	1
1	DNS Client	The device is capable of resolving host names by querying a DNS server.	0
2	DHCP Client	The device is capable of obtaining its network configuration via DHCP.	1

■ **Configuration Control**

The Configuration Control attribute is used to control network configuration options.

Table 4-16: Configuration Control

Bit(s)	Name	Definition
0-3	Startup Configuration	Determines how the device shall obtain its initial configuration at 0 = The device shall use the interface configuration values previously stored (for example, in non-volatile memory or via hardware switches, etc). 1 to 3: reserved
4	DNS Enable	Always 0.
5-31	reserved	Set to 0.

■ **Interface Configuration**

This attribute contains the configuration parameters required to operate as a TCP/IP node. To modify the Interface Configuration attribute, get the Interface Configuration attribute first, change the desired parameters, then set the attribute. The TCP/IP Interface Object applies the new configuration upon completion of the Set service. If the value of the Startup Configuration bits (Configuration Control attribute) is 0, the new configuration is stored in non-volatile memory. The device does not reply to the set service until the values are safely stored to non-volatile memory. An attempt to set any of the components of the Interface Configuration attribute to invalid values results in an error (status code 0x09) returned from the Set service. If initial configuration is obtained via BOOTP or DHCP, the Interface Configuration attribute components are all 0 until the BOOTP or DHCP reply is received. Upon receipt of the BOOTP or DHCP reply, the Interface Configuration attribute shows the configuration obtained via BOOTP/DHCP.

■ **Host Name**

The Host Name attribute contains the device’s host name. The host name attribute is used when the device supports the DHCP-DNS Update capability and has been configured to use DHCP upon start up. The mechanism allows the DHCP client to transmit its host name to the DHCP server. The DHCP server then updates the DNS records on behalf of the client.

Figure 4-1:
TCP/IP object
state diagram
(acc. to CIP
Spec., Vol.2, Rev.
1.1)

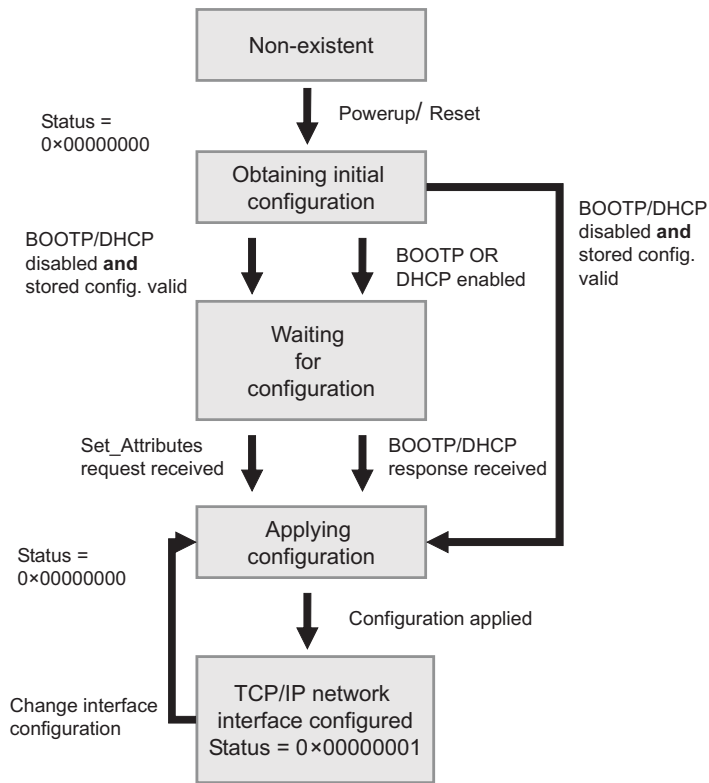

4.2.6 Ethernet Link Object (0xF6)

The following description of the Ethernet Link Object is taken from the CIP specification, Vol. 2, Rev. 1.1 by ODVA & ControlNet International Ltd. and adapted to BL20.

Class Attributes

Table 4-17: Class Attributes

Attr. No.	Attribute name	Get/Set	Type	Value
1 (0x01)	REVISION	G	UINT	1
2 (0x02)	MAX OBJECT INSTANCE	G	UINT	1
3 (0x03)	NUMBER OF INSTANCES	G	UINT	1
6 (0x06)	MAX CLASS IDENTIFIER	G	UINT	7
7 (0x07)	MAX INSTANCE ATTRIBUTE	G	UINT	6

Instance Attributes

Table 4-18: Instance attributes

Attr. No.	Attribute name	Get/Set	Type	Description
1 (0x01)	INTERFACE SPEED	G	UDINT	Speed in megabits per second (e.g., 10, 100, 1000, etc.)
2 (0x02)	INTERFACE FLAGS	G	DWORD	see Table 4-19: Interface flags
3 (0x03)	PHYSICAL ADDRESS	G	ARRAY OF USINT	Contains the interface's MAC address (TURCK: 00:07:46:xx:xx:xx)
6 (0x06)	INTERFACE CONTROL		2 WORD	Allows port-wise changes of the Ethernet-settings
7 (0x07)	INTERFACE TYPE			
10 (0x0A)	INTERFACE LABEL			

Table 4-19: Interface flags

Bits	Name	Definition	Default value
0	Link Status	Indicates whether or not the Ethernet 802.3 communications interface is connected to an active network. 0 = inactive link 1 = active link.	Depends on application
1	Half / Full Duplex	0 = half duplex; 1 = full duplex If the Link Status flag is 0, the value of the Half/Full Duplex flag is indeterminate.	Depends on application

*Table 4-19:
Interface flags*

Bits	Name	Definition	Default value
2 to 4	Negotiation Status	Indicates the status of the automatic duplex-negotiation (auto-negotiation) 0 = Auto-negotiation in progress 1 = Auto-negotiation and speed detection failed. Using default values for speed and duplex (10Mbps/half duplex). 2 = Auto negotiation failed but detected speed (default: half duplex). Half duplex 3 = Successfully negotiated speed and duplex. 4 = Auto-negotiation not attempted. Forced speed and duplex.	Depends on application
5	Manual Setting Requires Reset	0 = interface can activate changes to link parameters (auto-negotiate, duplex mode, interface speed) automatically 1 = device requires a Reset service to be issued to its Identity Object in order to adapt the changes	0
6	Local Hardware Fault	0 = interface detects no local hardware fault 1 = a local hardware fault is detected	0

Common Services

*Table 4-20:
Common services*

Service-Code	Class	Instance	Service name
01 (0x01)	yes	yes	Get_Attribute_All
14 (0x0E)	yes	yes	Get_Attribute_Single
76 (0x4C)	no	yes	Enetlink_Get_and_Clear

4.3 VSC-Vendor Specific Classes

In addition to supporting the above named CIP Standard Classes, the BL20-stations support the vendor specific classes described in the following.

Table 4-21: VSC-Vendor Specific Classes

Class Code dec. (hex.)	Name	Description
100 (64h)	Gateway Class, page 4-17	Contains data and settings concerning the fieldbus-specific part of the BL20-stations.
102 (66h)	Process Data Class, page 4-20	Contains process data
126 (1Ah)	Miscellaneous Parameters Class, page 4-22	Describes the EtherNet/IP™-Port properties

4.3.1 Class Instance of the VSCs



Note

The class instance attributes are the same for each Vendor Specific Class. The class-specific Object Instances and the corresponding attributes are explained in the paragraphs for the different VSC.

The general VSC class instance attributes are defined as follows.

Table 4-22: Class instance

Attr. No. dec. (hex.)	Attribute name	Get/ Set	Type	Description
100 (64h)	Class revision	G	UINT	States the revision number of the class (maj. rel. *1000 + Min. Rel.).
101 (65h)	Max. instance	G	USINT	Contains the number of the highest instance of an object created on this level in the class hierarchy.
102 (66h)	# of instances	G	USINT	Contains the number of Object Instances created in this class.
103 (67h)	Max. class attribute	G	USINT	Contains the number of the last Class Attribute to be implemented.

4.3.2 Gateway Class (VSC 100, 64h)

This class contains all information which refers to the whole station not to the different I/O channels.

Class instance



Note

Please refer to paragraph [Class Instance of the VSCs \(page 4-16\)](#) for the description of the class instance for the VSC.

Object Instance 1

Table 4-23:
Object Instance
1
Boot instance

Attr. No.	Attribute name	Get/ Set	Type	Description
dec. (hex.)				
100 (64h)	Max object attribute	G	USINT	Contains the number of the last object attribute to be implemented.
101 (65h)	Hardware revision	G	STRUCT	Contains the hardware revision number of the station (USINT Maj./USINT Min.)
102 (66h)	Firmware revision	G	STRUCT	Contains the firmware revision of the boot firmware (maj./min.).
103 (67h)	Service tool ident number	G	UDINT	Contains the BOOT ID number that serves as an identification number for the software I/O-ASSISTANT
104 (68h)	Hardware info	G	STRUCT	Contains station hardware information (UINT): – count (number of the following entries) – CLOCK FREQUENCY (kHz) – MAIN FLASH (in kB) – MAIN FLASH SPEED (ns) – SECOND FLASH (kB) – RAM (kB), – RAM SPEED (ns), – RAM data WIDTH (bit), – SERIAL EEPROM (kbit) – RTC SUPPORT (in #) – AUTO SERVICE BSL SUPPORT (BOOL) – HDW SYSTEM

Object Instance 2

Table 4-24: Object instance 2, gateway instance	Attr. No. dec. (hex.)	Attribute name	Get/ Set	Type	Description
	109 (6Dh)	Status register 2	G	STRUCT	<p>The Status Word contains general station status information:</p> <p>Station</p> <ul style="list-style-type: none"> – Bit 15: reserved – Bit 14: "Force Mode Active Error" The Force Mode is activated. – Bit 13: reserved – Bit 12: reserved <p>Internal bus</p> <ul style="list-style-type: none"> – Bit 11: "I/O Cfg Modified Error" The configuration has been changed in an incompatible way. – Bit 10: "I/O Communication Lost Error" Communication on the internal module bus disturbed. <p>Voltage errors</p> <ul style="list-style-type: none"> – Bit 09: "U_{sys} too low" System voltage too low (< 18 VDC). – Bit 08: "U_{sys} too high" System supply voltage too high (> 30 VDC). – Bit 07: "U_L too low" Load voltage too low (< 18 VDC). – Bit 06: reserved – Bit 05: reserved – Bit 04: reserved <p>Warnings</p> <ul style="list-style-type: none"> – Bit 03: "I/O Cfg Modified Warning" The station configuration has changed. – Bit 02: reserved – Bit 01: reserved – Bit 00: "I/O Diags Active Warning" At least one I/O-channel sends active diagnostics.
	115 (73h)	ON IO CONNECTION TIMEOUT	G/S	ENUM USINT	<p>Reaction to the I/O connection exceeding the time limit.</p> <p>SWITCH IO FAULTED (0): The modules are switched to Faulted State.</p> <p>SWITCH IO OFF (1): The gateway switches off the outputs of the modules.</p> <p>SWITCH IO HOLD (2): No further changes to the I/O-data. The outputs are held.</p>
	138 (0x8A)	GW Status Register	Get/ Set	DWORD	<p>Allows to enable/disable the status register which is part of the input data.</p> <p>0 = deactivated 1 = activated (default)</p>

*Table 4-24:
Object instance
2, gateway
instance*

Attr. No. dec. (hex.)	Attribute name	Get/ Set	Type	Description
139 (0x8B)	GW Control Register	Get/ Set	DWORD	Allows to enable/disable the control register which is part of the output data. 0 = deactivated 1 = activated (default)
140 (0x8C)	Disable Protocols	Get/ Set	UINT	Deactivate the other Ethernet-protocols, if necessary: 0 = EtherNet/IP™ (can not be disabled via EtherNet/IP™-interface) Bit 1 = Modbus/TCP Bit 2 = PROFINET® Bit 15 = web server

4.3.3 Process Data Class (VSC102, 66h)

This class contains the process-relevant information.

Class instance



Note

Please refer to paragraph [Class Instance of the VSCs, page 4-16](#) for the description of the class instance for the VSC.

Object instance 1, standard input process data (compressed)

Table 4-25:
Object instance
1, standard
input process
data (com-
pressed)

Attr. No. dec. (hex.)	Attribute name	Get/ Set	Type	Description
100 (64h)	Max object attribute	G	USINT	Contains the number of the last object attribute to be implemented.
101 (65h)	Attribute list	G	ARRAY OF USINT	List of all attributes that are supported by this instance.
102 (66h)	Packed process input data	G	ARRAY OF WORD	Input process data, 16-bit aligned, compressed.
103 (67h)	Process data byte count	G	USINT	The number of bytes that are exchanged with this Instance.

Object instance 2, standard output process data (compressed)

Table 4-26:
Object instance
2, standard out-
put process data
(compressed)

Attr. No. dec. (hex.)	Attribute name	Get/ Set	Type	Description
100 (64h)	Max object attribute	G	USINT	Contains the number of the last object attribute to be implemented.
101 (65h)	Attribute list	G	ARRAY OF USINT	List of all attributes that are supported by this Instance.
102 (66h)	Packed process input data	G/S	ARRAY OF WORD	Output process data, 16-bit aligned, compressed.
103 (67h)	Process data byte count	G	USINT	The number of bytes that are exchanged with this Instance.

Object Instance 3, diagnostic instance

Table 4-27:
Object Instance
3, diagnostic
instance

Attr. No. dec. (hex.)	Attribute name	Get/ Set	Type	Description
104 (68h)	GW summarized diagnostics	G/S	BOOL	0 = disabled 1 = active 1 bit of diagnosis mapped at the end of the input data image (page 4-2). Changes become valid after a start-up!
105 (69h)	GW manufacturer specific diagnostics (scheduled diagnostics)	G/S	BOOL	0 = disabled 1 = active The channel-specific diagnostic bits are mapped into the process input data (see page 4-2). Changes become valid after a start-up!
106 (6Ah)	reserved			-

Object Instance 4, COS/CYCLIC instance

Table 4-28:
Object Instance
4, COS/CYCLIC
instance

Attr. No. dec. (hex.)	Attribute name	Get/ Set	Type	Description
104 (68h)	COS data mapping	G/S	ENUM USINT	The actual data are loaded to the non-volatile memory of the station. Changes become valid after a start-up! 0 = standard: Data of COS message → input data. 1 = process input data (only the process data input image is transferred to scanner) 2 to 7: reserved

4.3.4 Miscellaneous Parameters Class (VSC 126)

Instance 1 (port 1)/ Instance 2 (port 2)

<i>Table 4-29: Object Instance</i>	Attr. No. dec. (hex.)	Attribute name	Get/ Set	Type	Description
A default setting	109 (6Dh)	Ethernet port Parameters	G/S	DWORD	0 = Autonegotiate, AutoMDIX A 1 = 100BaseT, half duplex, linear topology (AutoMDIX disabled) 2 = 10BaseT, full duplex, linear topology (AutoMDIX disabled) 3 = 100BaseT, half duplex, linear topology (AutoMDIX disabled) 4 = 100BaseT, full duplex, linear topology (AutoMDIX disabled)
	112 (70h)	IO controller software revision	G	DWORD	The number of instances of this parameter depends on the number of I/O controllers.

5 Application example: BL20-E-GW-EN with EtherNet/IP™ (Allen Bradley)

5.1	General	5-2
5.1.1	Used hard-/ software	5-2
	– Hardware.....	5-2
	– Software.....	5-2
5.2	Network configuration	5-3
5.2.1	Configuration of the network in "RS Logix 5000"	5-3
	– Configuration of the controller	5-3
	– Configuring the BL20-station	5-4
5.2.2	Downloading the I/O configuration	5-7
5.3	I/O data mapping	5-9
5.4	Process data access	5-11
5.4.1	Setting outputs	5-11
5.4.2	Example program.....	5-12

Application example: BL20-E-GW-EN with EtherNet/IP™ (Allen Bradley)

5.1 General

The following example shows detailed information about the connection of a BL20-station for EtherNet/IP™ to an Allen Bradley PLC.

5.1.1 Used hard-/ software

Hardware

Hardware used in this example:

- Allen Bradley PLC 1769-L30-ER/A Compact Logix5330ER Controller
- BL20-E-GW-EN (> VN 03-00, IP: 192.168.1.16)
 - Slot 1: BL20-2DI-24VDC-P
 - Slot 2: BL20-4DI-24VDC-P
 - Slot 3: BL20-1AI-U(-10/0...+10VDC)
 - Slot 4: BL20-2AI-THERMO-PI
 - Slot 5: BL20-2DO-24VDC-0.5A-P
 - Slot 6: BL20-E-8DO-24VDC-0.5A-P

Software

Software used in this example:

- RS Logix 5000 - used to configure the controller and the other network hosts

5.2 Network configuration

BL20-stations are delivered in the address-mode "PGM-DHCP" and can be reached using IP-address **192.168.1.254** .



Note

In order to build up the communication between the BL20-station and a PLC/ PC or a network interface card, both devices have to be hosts in the same network.

To achieve this, you have either:

- to adjust the gateway's IP address via BootP, DHCP etc. for integrating it into your own network (for detailed information about the different possibilities for address setting, please read [chapter 3.5, Address assignment \(page 3-15\)](#), .

or

- to change the IP address of the used PC or network interface card (for detailed information, please read the , [Changing the IP address of a PC/ network interface card \(page 13-16\)](#)).

5.2.1 Configuration of the network in "RS Logix 5000"

The EtherNet/IP™ hosts (PLC, EtherNet/IP™ interface, I/O stations) have to be configured using the software "RSLogix 5000" (in this example version 15) from Rockwell Automation.

Start RS Logix and open a new project using the "File" menu.

Configuration of the controller

- 1 Enter the information related to the controller depending on your configuration, as well as a name for the project.

Figure 5-1:
Configuration
of the controller

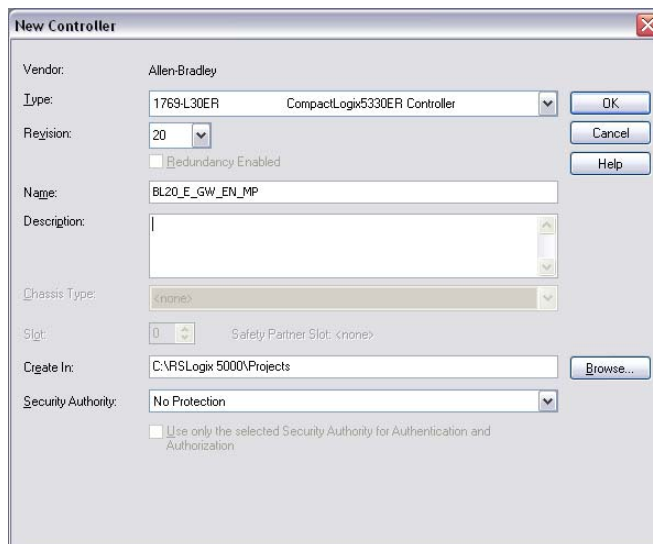

- 2 Your project will be opened offline.

Configuring the BL20-station

- 3 Open the context menu by right-clicking "Ethernet" and select "New Module" in order to add the BL20-station to the network.
- 4 Open "Communications" and select the entry "Generic Ethernet Module" to configure the station.

Figure 5-2:
Add generic
Ethernet mod-
ule

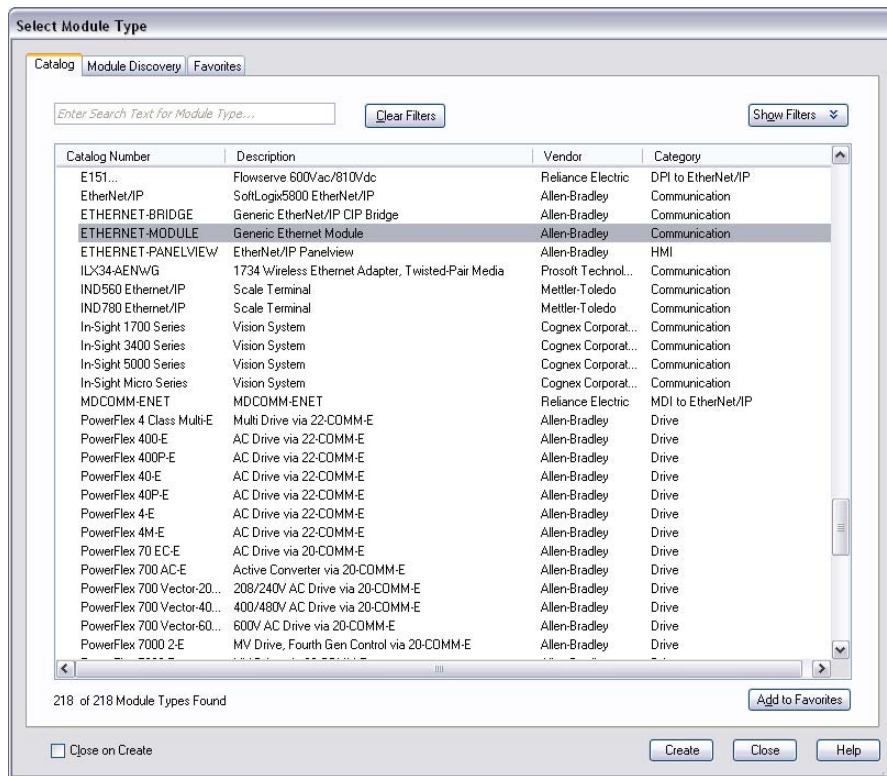

- 5 Enter the necessary device information, like "Module name" and "Communication format" and define the station's IP-address and the connection parameters.
- 6 In the Assembly Instances 103 and 104, please enter the connection parameters of the station.

Figure 5-3:
Configuring the
BL20-
station

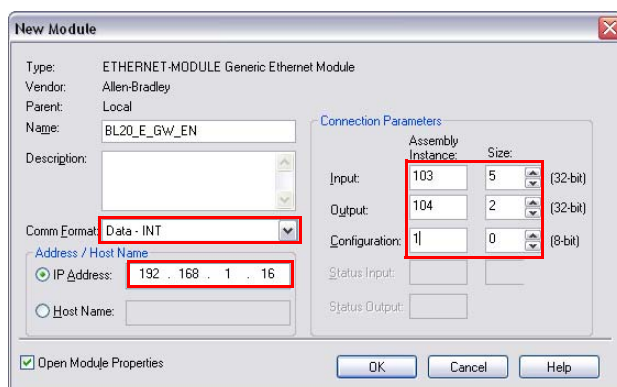



Note

If the variable Assembly Instances 103 and 104 (see [page 4-6](#)) are used, the Connection Parameters have to be set according to the actual station configuration.

That means:

The in- and output sizes have to match the sizes definitely required by the station.

This required in- and output size can be determined as follows:

Create a station report for the station using the TURCK DTMs for BLxx (see also [Figure 5-4: EtherNet/IP™-report \(PLC-configuration\) \(page 5-5\)](#))

OR

Read out the correct size of in- and output data via Assembly Class (0x04), Instance 0x67, Attr. 0x04 and Assembly Class (0x04), Instance 0x68, Attr. 0x04.

Figure 5-4:
EtherNet/IP™-
report (PLC-
configuration)

1. EtherNet/IP report

1.1. Station description

A Data to ente into
assembly
instances in RS
Logix

Station address: 192.168.1.112

Adr./Slot	Name	TAG	Descr.	Data Size In	Data Size Out
Slot 0*	BL20-E-GW-EN (>= VN 03-00)	192.168.1.112/BL20-E-GW-EN (>= VN 03-00)	Term0A	16 bit	16 bit
Slot 1	BL20-2DI-24VDC-P	01/BL20-2DI-24VDC-P	Term0B	2 bit	0 bit
Slot 2	BL20-4DI-24VDC-P	02/BL20-4DI-24VDC-P	Term0C	4 bit	0 bit
Slot 3	BL20-1AI-U(-10/0...+10VDC)	03/BL20-1AI-U(-10/0...+10VDC)	Term0D	16 bit	0 bit
Slot 4	BL20-2AI-THERMO-PI	04/BL20-2AI-THERMO-PI	Term0E	32 bit	0 bit
Slot 5	BL20-2DO-24VDC-0.5A-P	05/BL20-2DO-24VDC-0.5A-P	Term0F	0 bit	2 bit
Slot 6	BL20-E-8DO-24VDC-0.5A-P	06/BL20-E-8DO-24VDC-0.5A-P	Term0G	0 bit	8 bit
Local I/O data incl. status/control				5 Words	2 Words
Total size for in/out data rounded on full words				5 Words	2 Words

In the PLC Configuration software, the in - and output size entries for the assembly instances may be depicted in words (DATA -INT) or even in double-words (DATA - DINT). The I/O-ASSISTANT mapping results have thus to be converted into the respective data format.

PLC-configuration:
Values for Assembly Instance 103 (input data): 5 Words
Values for Assembly Instance 104 (output data): 2 Words



A

Note:

If a module with a firmware < 1.9 is used, the variable Assembly Instances 103 and 104 are not supported. In this case, the Assembly Instances 101 and 102 have to be used. The defined data width for each of these Instances is 128 words.

*For detailed information about the status word, please see online help. The control word is mapped into the process data, but has no function for the standard EtherNet/IP gateways. It can only be used in the EtherNet/IP gateways with DeviceNet™-master (see online help).

Application example: BL20-E-GW-EN with EtherNet/IP™ (Allen Bradley)

- In the "Connection" tab set the "Requested Packet Interval" (RPI) to 10 ms, which normally should be the default setting. For BL20, the RPI should be set to 5 ms or higher.

Figure 5-5:
Set connection
options for the
gateway

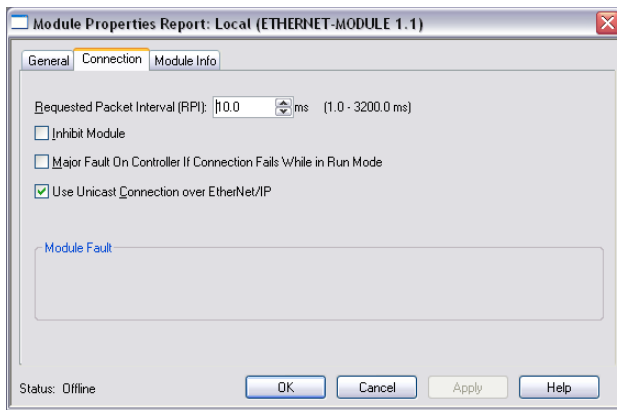

- The station is now added to the project tree.

Figure 5-6:
Project tree with
stations

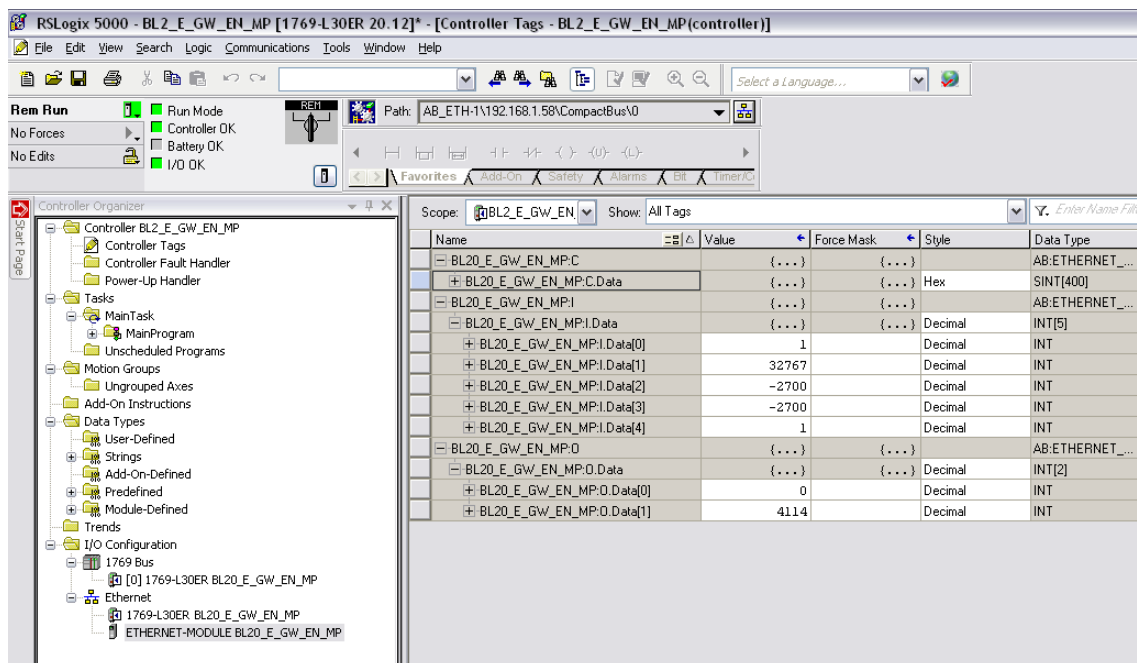

5.2.2 Downloading the I/O configuration

- 1 If the configuration of the network is completed, it can be downloaded to the controller by using for example the "Communication → Download" command.
- 2 In the "Download" dialog box, start the download by pressing the "Download" button.

Figure 5-7: Download of the configuration

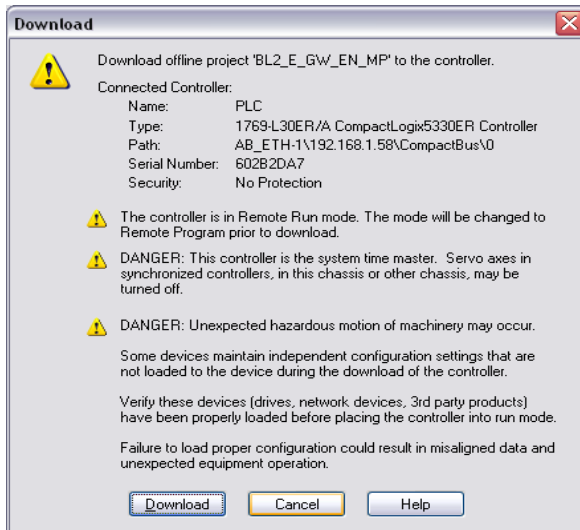

- 3 If an error message is generated, warning, that the communication path can not be found, please open the "Path" menu (see Figure 5-8:), select your controller and press "Set Project Path" (see Figure 5-9:).

Figure 5-8: Communication path

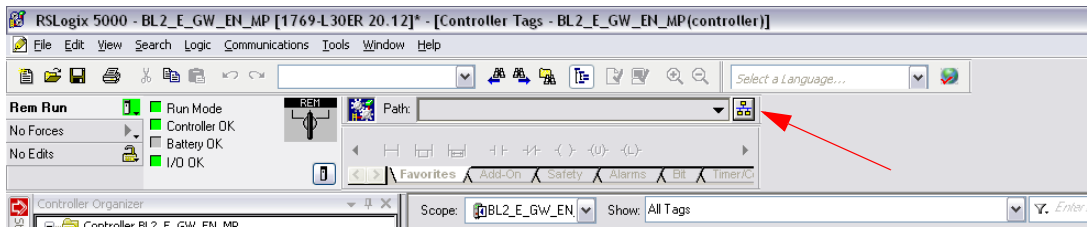
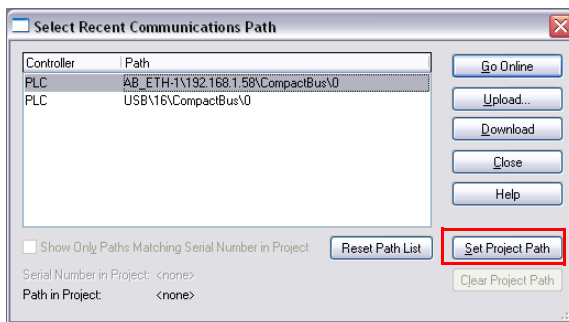

Figure 5-9: Communication path



- 4 If the correct communication path is set, it is possible to download the configuration.

Application example: BL20-E-GW-EN with EtherNet/IP™ (Allen Bradley)

- Once the I/O configuration is downloaded and the controller is in "Run" or "Remote Run" mode, the I/O-data mapping of the FGEN-stations is shown in the "Controller Tags":

Figure 5-10:
Controller Tags

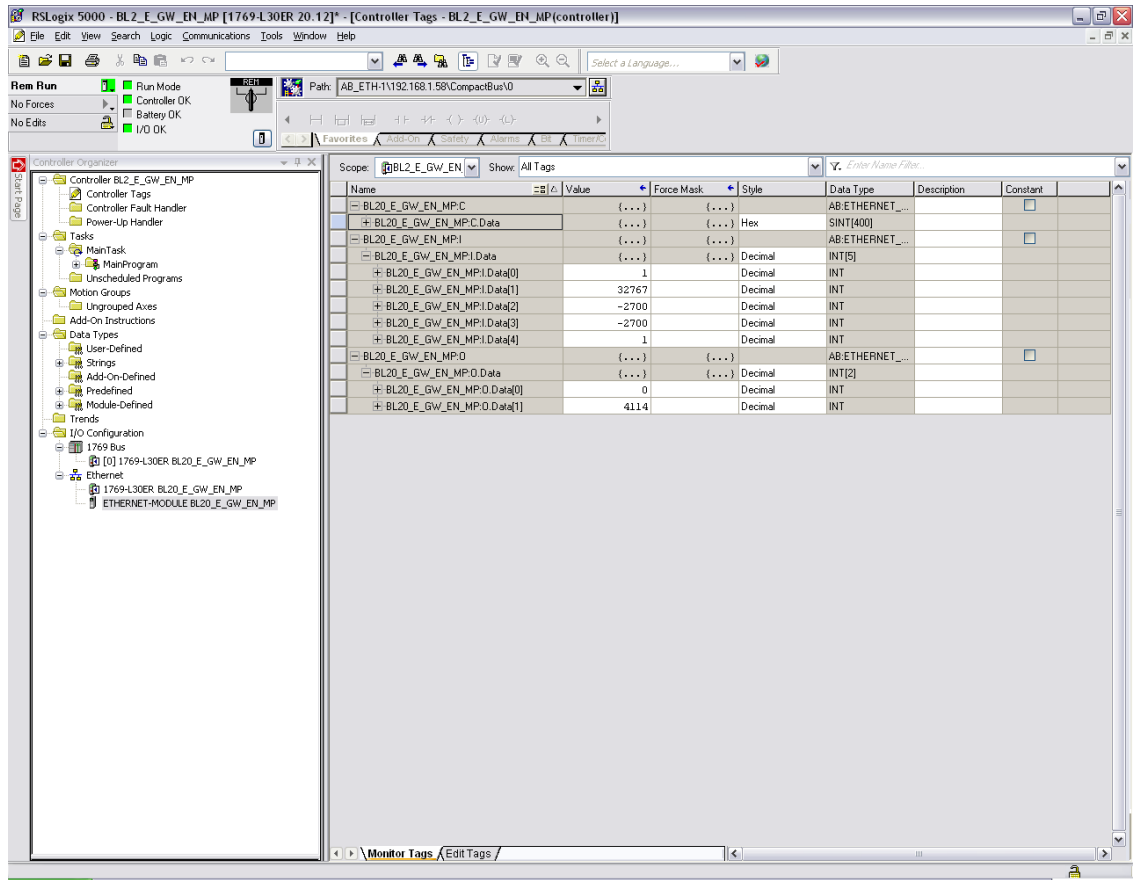

The controller tags are divided into:

- xxx: C - the station's mapped configuration data
- xxx: I - the station's mapped input data
- xxx: O - the station's mapped output data

5.3 I/O data mapping

Each station is now accessible via the controller tags for viewing input data and/or forcing outputs.

The data mapping depends on process data mappings of the configured FGEN-modules (see [chapter 4, Assembly Object \(0x04\), Mapping of process data \(page 4-8\)](#) ff.).

The detailed station data mapping can be found in the EtherNet/IP™-report, generated using the BLxx-PACTware-DTM.

Figure 5-11: EtherNet/IP™-report with data mapping

1. EtherNet/IP report

1.1. Station description

Station address: 192.168.1.112

Adr./Slot	Name	TAG	Descr.	Data Size In	Data Size Out
Slot 0*	BL20-E-GW-EN (>= VN 03-00)	192.168.1.112/BL20-E-GW-EN (>= VN 03-00)	Term0A	16 bit	16 bit
Slot 1	BL20-2DI-24VDC-P	01/BL20-2DI-24VDC-P	Term0B	2 bit	0 bit
Slot 2	BL20-4DI-24VDC-P	02/BL20-4DI-24VDC-P	Term0C	4 bit	0 bit
Slot 3	BL20-1AI-U(-10/0...+10VDC)	03/BL20-1AI-U(-10/0...+10VDC)	Term0D	16 bit	0 bit
Slot 4	BL20-2AI-THERMO-PI	04/BL20-2AI-THERMO-PI	Term0E	32 bit	0 bit
Slot 5	BL20-2DO-24VDC-0.5A-P	05/BL20-2DO-24VDC-0.5A-P	Term0F	0 bit	2 bit
Slot 6	BL20-E-8DO-24VDC-0.5A-P	06/BL20-E-8DO-24VDC-0.5A-P	Term0G	0 bit	8 bit
Local I/O data incl. status/control				5 Words	2 Words
Total size for in/out data rounded on full words				5 Words	2 Words

In the PLC Configuration software, the in - and output size entries for the assembly instances may be depicted in words (DATA -INT) or even in double-words (DATA - DINT).

The I/O-ASSISTANT mapping results have thus to be converted into the respective data format.

PLC-configuration:

Values for Assembly Instance 103 (input data): 5 Words

Values for Assembly Instance 104 (output data): 2 Words

Note:

If a module with a firmware < 1.9 is used, the variable Assembly Instances 103 and 104 are not supported. In this case, the Assembly Instances 101 and 102 have to be used. The defined data width for each of these Instances is 128 words.

*For detailed information about the status word, please see online help. The control word is mapped into the process data, but has no function for the standard EtherNet/IP gateways.

It can only be used in the EtherNet/IP gateways with DeviceNet™-master (see online help).

1.2. I/O map for input data

Bit	Byte n+1								Byte n							
	15	14	13	12	11	10	9	8	7	6	5	4	3	2	1	0
Word0*	0A.15	0A.14	0A.13	0A.12	0A.11	0A.10	0A.9	0A.8	0A.7	0A.6	0A.5	0A.4	0A.3	0A.2	0A.1	0A.0
Word1	-	-	-	-	-	-	-	-	-	-	0C.3	0C.2	0C.1	0C.0	0B.1	0B.0
Word2	0D.15	0D.14	0D.13	0D.12	0D.11	0D.10	0D.9	0D.8	0D.7	0D.6	0D.5	0D.4	0D.3	0D.2	0D.1	0D.0
Word3	0E.15	0E.14	0E.13	0E.12	0E.11	0E.10	0E.9	0E.8	0E.7	0E.6	0E.5	0E.4	0E.3	0E.2	0E.1	0E.0
Word4	0E.31	0E.30	0E.29	0E.28	0E.27	0E.26	0E.25	0E.24	0E.23	0E.22	0E.21	0E.20	0E.19	0E.18	0E.17	0E.16

*For detailed information about the status word, please see online help. The control word is mapped into the process data, but has no function for the standard EtherNet/IP gateways.

It can only be used in the EtherNet/IP gateways with DeviceNet™-master (see online help).

Process input data: 5 Words

1.3. I/O map for output data

Bit	Byte n+1								Byte n							
	15	14	13	12	11	10	9	8	7	6	5	4	3	2	1	0
Word0*	0A.15	0A.14	0A.13	0A.12	0A.11	0A.10	0A.9	0A.8	0A.7	0A.6	0A.5	0A.4	0A.3	0A.2	0A.1	0A.0
Word1	-	-	-	-	-	-	0G.7	0G.6	0G.5	0G.4	0G.3	0G.2	0G.1	0G.0	0F.1	0F.0

*For detailed information about the status word, please see online help. The control word is mapped into the process data, but has no function for the standard EtherNet/IP gateways.

It can only be used in the EtherNet/IP gateways with DeviceNet™-master (see online help).

Process output data: 2 Words

Application example: BL20-E-GW-EN with EtherNet/IP™ (Allen Bradley)

For the example station, the mapping in RS Logix looks as follows:

Figure 5-12:
Mapping of the
BL20-station

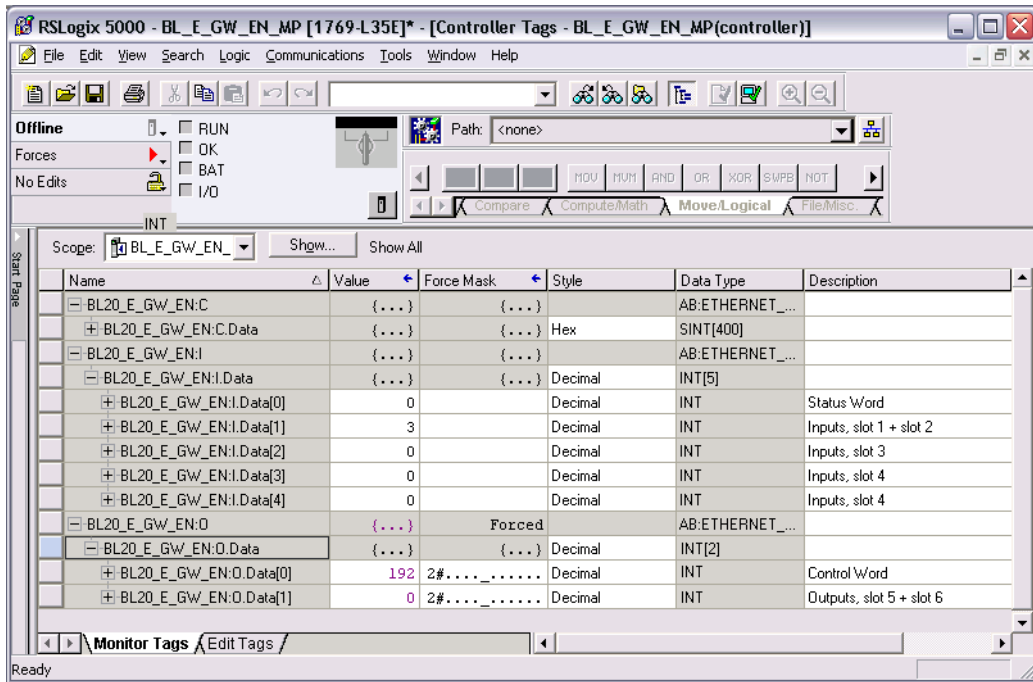

5.4 Process data access

5.4.1 Setting outputs

Example:

In order to set outputs "0" and "1" at slot 5 of the station (BL20-2DO-24VDC-0.5A-P, see example station), bit 0 and bit 1 in data word 1 (BL20_E_GW_EN:I.Data [1]) have to be set (see above [Figure 5-9:I/O data mapping \(page 5-9\)](#)).

Figure 5-13:
Setting outputs
at BL20-2DO-
24VDC-0.5A-P

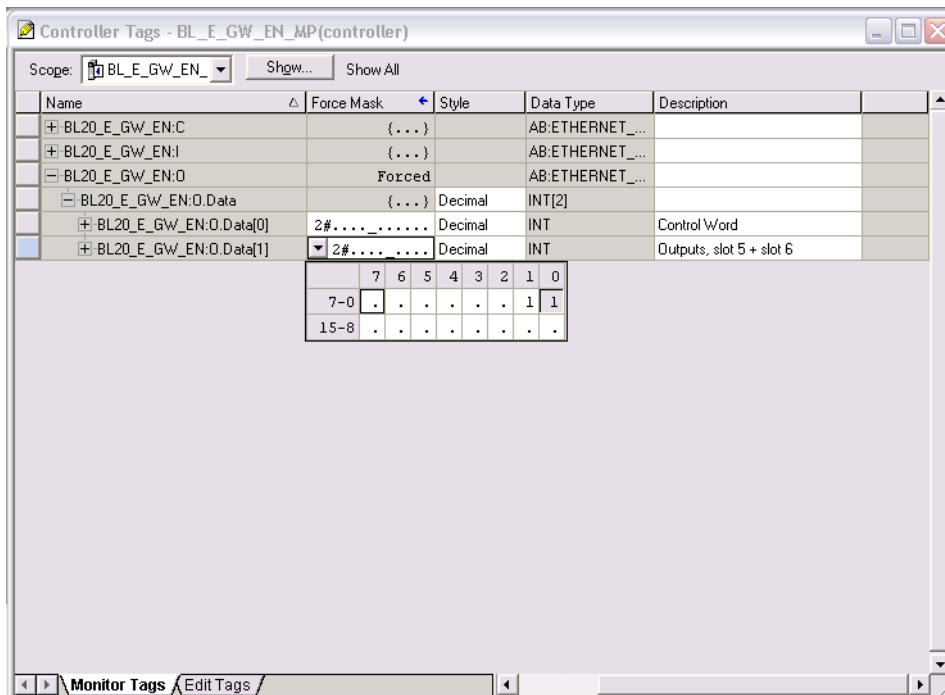

5.4.2 Example program

Figure 5-14:
Example
program

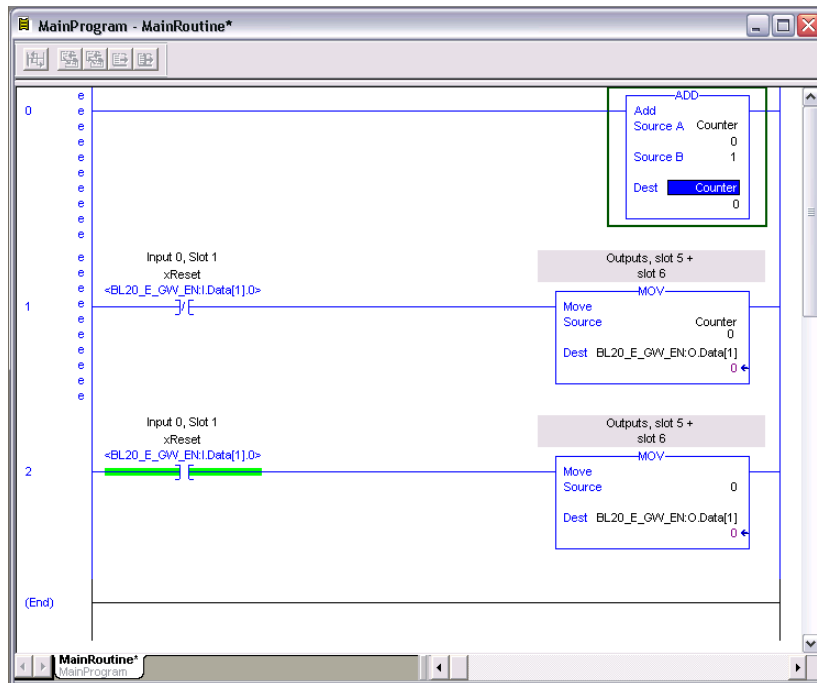

- 1 The counter counts upwards.
- 2 The counter value is mapped to the outputs of the two digital output modules in the station (slot 5 and slot 6).

Application example: BL20-E-GW-EN with EtherNet/IP™ (Allen Bradley)

6 Implementation of Modbus TCP

6.1	Common Modbus description.....	6-2
6.1.1	Protocol description.....	6-3
6.1.2	Data model.....	6-4
6.2	Implemented Modbus functions.....	6-6
6.3	Modbus registers.....	6-7
6.3.1	Structure of the packed in-/ output process data	6-12
	– Packed input process data.....	6-12
	– Packed output process data.....	6-13
	– Data width of the I/O-modules in the modbus-register area	6-14
6.3.2	Register 0x100C: Gateway status.....	6-16
6.3.3	Register 0x1130h: Modbus-Connection-Mode	6-17
6.3.4	Register 0x1131: Modbus-Connection-Timeout.....	6-17
6.3.5	Register 0x113C and 0x113D: Restore Modbus-connection parameters.....	6-17
6.3.6	Register 0x113E and 0x113F: „Save Modbus-Connection-Parameters“	6-18
6.3.7	Register 0x1140: Disable protocol	6-18
6.3.8	Register 0x1141: Active protocol.....	6-18
6.3.9	Register 0x2000 bis 0x207F: The Service-Object	6-19
	– Indirect reading of registers	6-20
	– Indirect writing of registers	6-21
6.4	Bit areas: mapping of input-discrete- and coil-areas	6-22
6.5	Error behavior of outputs (watchdog).....	6-23

6.1 Common Modbus description



Note

The following description of the Modbus protocol is taken from the Modbus Application Protocol Specification V1.1 of Modbus-IDA.

Modbus is an application layer messaging protocol, positioned at level 7 of the OSI model, that provides client/server communication between devices connected on different types of buses or networks.

The industry's serial de facto standard since 1979, Modbus continues to enable millions of automation devices to communicate. Today, support for the simple and elegant structure of Modbus continues to grow.

The Internet community can access Modbus at a reserved system port 502 on the TCP/IP stack.

Modbus is a request/reply protocol and offers services specified by function codes. Modbus function codes are elements of Modbus request/reply PDUs (Protocol Data Unit).

It is currently implemented using:

- TCP/IP over Ethernet. (that is used for the BLxx-gateways for Modbus TCP and described in the following)
- Asynchronous serial transmission over a variety of media (wire: RS232, RS422, RS485, optical: fiber, radio, etc.)
- Modbus PLUS, a high speed token passing network.

Schematic representation of the Modbus Communication Stack (according to Modbus Application Protocol Specification V1.1 of Modbus-IDA):

Figure 6-1: Schematic representation of the Modbus Communication Stack

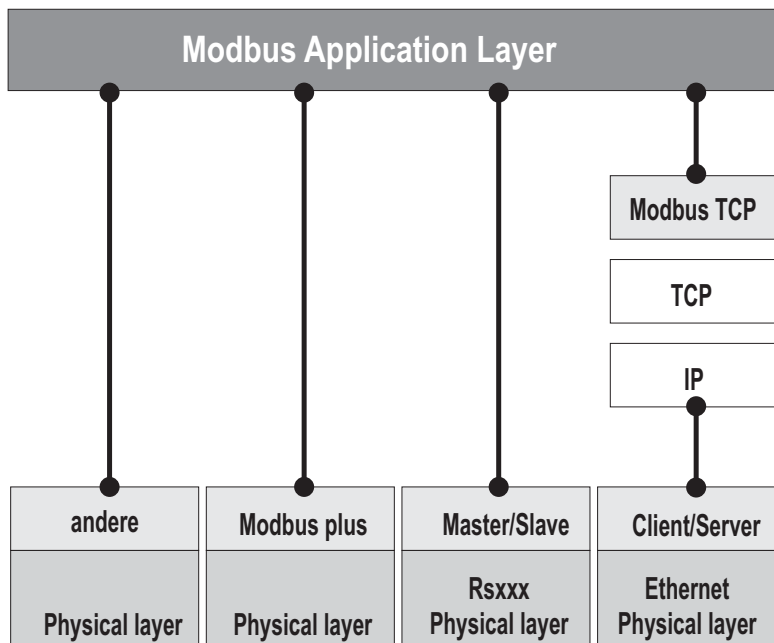

6.1.1 Protocol description

The Modbus protocol defines a simple protocol data unit (PDU) independent of the underlying communication layers.

The mapping of Modbus protocol on specific buses or network can introduce some additional fields on the application data unit (ADU).

Figure 6-2:
Modbus telegram acc. to Modbus-IDA

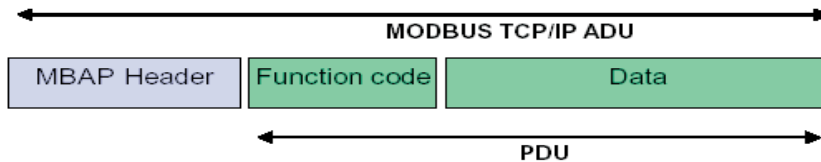

The Modbus application data unit is built by the client that initiates a Modbus transaction.

The function code indicates to the server what kind of action to perform.

The Modbus application protocol establishes the format of a request initiated by a client.

The field function code of a Modbus data unit is coded in one byte. Valid codes are in the range of 1..255 decimal (128 – 255 reserved for exception responses).

When a message is sent from a Client to a Server device the function code field tells the server what kind of action to perform. Function code "0" is not valid.

Sub-function codes are added to some function codes to define multiple actions.

The data field of messages sent from a client to server devices contains additional information that the server uses to take the action defined by the function code. This can include items like discrete and register addresses, the quantity of items to be handled, and the count of actual data bytes in the data field.

The data field may be non-existent (= 0) in certain kinds of requests, in this case the server does not require any additional information. The function code alone specifies the action.

If no error occurs related to the Modbus function requested in a properly received Modbus ADU the data field of a response from a server to a client contains the data requested.

Figure 6-3:
Modbus data transmission (acc. to Modbus-IDA)

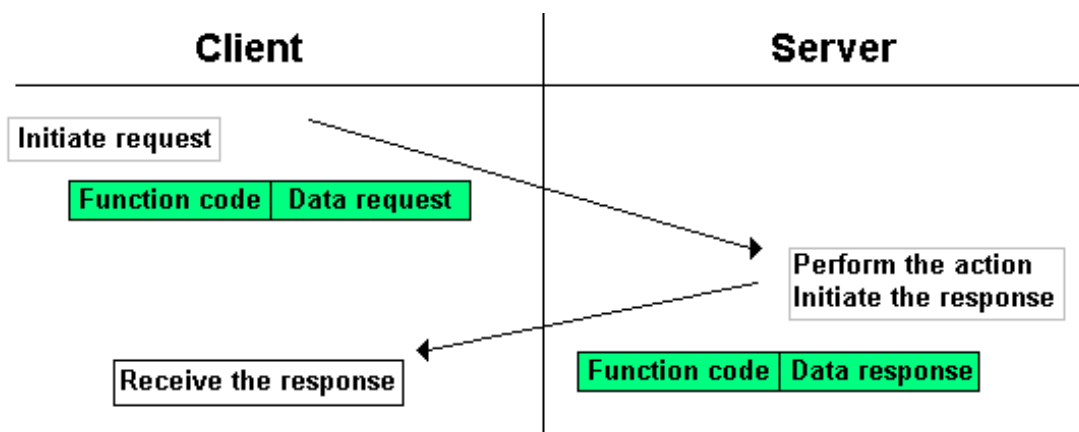

If an error related to the Modbus function requested occurs, the field contains an exception code that the server application can use to determine the next action to be taken.

Figure 6-4:
Modbus data
transmission
(acc. to
Modbus-IDA)

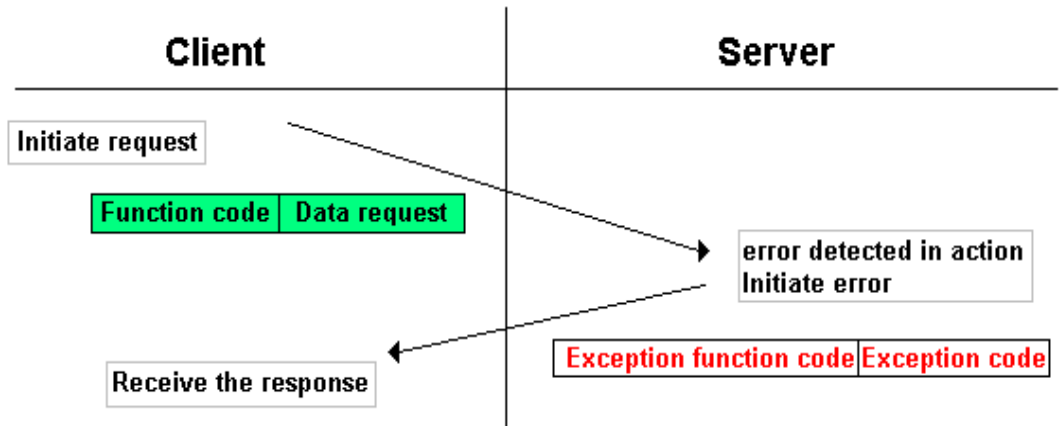

6.1.2 Data model

The data model distinguishes 4 basic data types:

Table 6-1:
Data types for
Modbus

Data Type	Object type	Access	Comment
Discrete Inputs	Bit	Read	This type of data can be provided by an I/O system.
Coils	Bit	Read-Write	This type of data can be alterable by an application program.
Input Registers	16-bit, (word)	Read	This type of data can be provided by an I/O system.
Holding Registers	16-bit, (word)	Read-Write	This type of data can be alterable by an application program.

For each of these basic data types, the protocol allows individual selection of 65536 data items, and the operations of read or write of those items are designed to span multiple consecutive data items up to a data size limit which is dependent on the transaction function code.

It's obvious that all the data handled via Modbus (bits, registers) must be located in device application memory.

Access to these data is done via defined access-addresses (see „Modbus registers“, [page 6-7](#)).

The example below shows the data structure in a device with digital and analog in- and outputs.

BL20 devices have only one data block, whose data can be accessed via different Modbus functions. The access can be carried out either via registers (16-bit-access) or, for some of them, via single-bit-access.

Figure 6-5:
Picture of the
data memory of
the BL20
modules

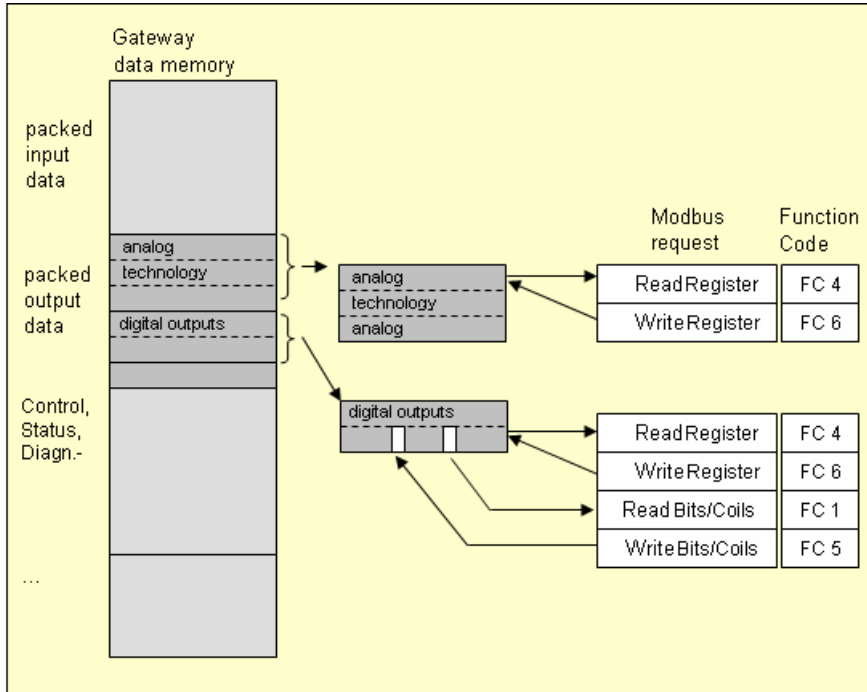

6.2 Implemented Modbus functions

The BL20-gateways for Modbus TCP support the following functions for accessing process data, parameters, diagnostics and other services.

Table 6-2:
Implemented
functions

Function codes	
No.	Function
	Description
1	Read Coils Serves for reading multiple output bits.
2	Read Discrete Inputs Serves for reading multiple input bits.
3	Read Holding Registers Serves for reading multiple output registers.
4	Read Input Registers Serves for reading multiple input registers.
5	Write Single Coil Serves for writing a single output bit.
6	Write Single Register Serves for writing a single output register.
15	Write Multiple Coils Serves for writing multiple output bits.
16	Write Multiple Registers Serves for writing multiple output registers.
23	Read/Write Multiple Registers Reading and writing of multiple registers.

6.3 Modbus registers



Note

The [Table 6-5](#), [page 6-14](#) shows the register mapping for the different Modbus addressing methods.

Table 6-3:
Modbus registers of the module

A ro = read only
rw = read/write

Address (hex.)	Access A	Description
0x0000 to 0x01FF	ro	packed process data of inputs (process data length of the modules → see Table 6-5: Data width of the I/O-modules)
0x0800 to 0x09FF	rw	packed process data of outputs (process data length of the modules → see Table 6-5: Data width of the I/O-modules)
0x1000 to 0x1006	ro	gateway identifier
0x100C	ro	Gateway status (see Table 6-6: Register 100Ch: Gateway status)
0x1010	ro	process image length in bit for the intelligent output modules
0x1011	ro	process image length in bit for the intelligent input modules
0x1012	ro	process image length in bit for the intelligent output modules
0x1013	ro	process image length in bit for the intelligent input modules
0x1017	ro	Register-mapping-revision (always 1, if not, mapping is incompatible with this description)
0x1018 to 0x101A	ro	group diagnostics of I/O-modules 0 to 32 (1 bit per I/O module)
0x1020	ro	watchdog, actual time [ms]
0x1120	rw	watchdog predefined time [ms] (default: 0), see also Error behavior of outputs (watchdog) (page 6-23))
0x1121	rw	Watchdog reset register
0x1130	rw	Modbus connection mode register, page 6-17
0x1131	rw	Modbus connection timeout in sec. (Def.: 0 = never), page 6-17
0x113C to 0x113D	rw	Modbus parameter restore, page 6-17 (reset of parameters to default values)

Table 6-3:
Modbus registers of the module

Address (hex.)	Access A	Description
0x113E to 0x113F	rw	Modbus parameter save, page 6-18 (permanent storing of parameters)
0x1140 (VN 03-00 and higher)	rw	Disable Protocol, page 6-18
0x1141 (VN 03-00 and higher)	ro	Active Protocol, page 6-18
0x2000 to 0x207F	rw	service-object, request-area, page 6-19
0x2080 to 0x20FF	ro	service-object, response-area, page 6-19
0x2400	ro	System voltage U_{SYS} [mV]
0x2401	ro	Load voltage U_L [mV]
0x2405	ro	load current I_L [A]
0x27FE	ro	no. of entries in actual module list
0x27FF	rw	no. of entries in reference module list
0x2800 to 0x283F	rw	Reference module list (max. 32 modules per station \times 2 registers for module-ID)
0x2A00 to 0x2A3F	ro	Actual module list (max. 32 modules per station \times 2 registers for module-ID)
0x8000 to 0x8400	ro	process data inputs (max. 32 modules per station \times 32 registers for module-ID)
0x9000 to 0x9400	rw	process data outputs (max. 32 modules per station \times 32 registers for module-ID)
0xA000 to 0xA400	ro	Diagnosis (max. 32 modules per station \times 32 registers for module-ID)
0xB000 to 0xB400	rw	Parameters (max. 32 modules per station \times 32 registers for module-ID)

The following table shows the register mapping for the different Modbus addressing methods

Table 6-4:
Mapping of
BL20-E-GW-EN
Modbus regis-
ters (holding
registers)

Description	Hex	Decimal	5-digit	Modicon
packed input data	0x0000 to 0x01FF	0 to 511	40001 to 40512	400001 to 400512
packed output data	0x0800 to 0x09FF	2048 to 2549	42049 to 42560	402049 to 402560
gateway identifier	0x1000 to 0x1006	4096 to 4102	44097 to 44103	404097 to 404103
Gateway status	0x100C	4108	44109	404109
process image length in bit for the intelligent output modules	0x1010	4112	44113	404113
process image length in bit for the intelligent input modules	0x1011	4113	44114	404114
process image length in bit for the digital output modules	0x1012	4114	44115	404115
process image length in bit for the digital input modules	0x1013	4115	44116	404116
Register-mapping-revision	0x1017	4119	44120	404120
group diagnostics of I/O-modules 1 to 32 (1 bit per I/O module)	0x1018 to 0x1019	4120 to 4121	44121 to 44122	404121 to 404122
watchdog, actual time	0x1020	4128	44129	404129
watchdog, predefined time	0x1120	4384	44385	404385
Watchdog reset register	0x1121	4385	44386	404386
Modbus connection mode register	0x1130	4400	44401	404401
Modbus connection timeout in sec.	0x1131	4401	44402	404402
Modbus parameter restore	0x113C to 0x113D	4412 to 4413	44413 to 44414	404413 to 404414
Modbus parameter save	0x113E to 0x113F	4414 to 4415	44415 to 44416	404415 to 404416
service-object, request-area,	0x2000 to 0x207F	8192 to 8319	48193 to 48320	408193 to 408320

Table 6-4:
Mapping of
BL20-E-GW-EN
Modbus regis-
ters (holding
registers)

Description	Hex	Decimal	5-digit	Modicon
Disable protocol (VN 03-00 and higher)	0x1140	4416	44417	404417
Active protocol (VN 03-00 and higher)	0x1141	4417	44418	404418
service-object, response-area,	0x2080	8320	48321	408321
	to 0x20FF	to 8447	to 48448	to 408448
System voltage U_{SYS} [mV]	0x2400	9216	49217	409217
Load voltage U_L [mV]	0x2401	9217	49218	409218
load current I_L [A]	0x2405	9221	49222	409222
no. of entries in actual module list	0x27FE	10238	-	410239
no. of entries in reference module list	0x27FF	10239	-	410240
Reference module list (max. 32 modules per station × 2 registers for module-ID)	0x2800 to 0x283F	10240 to 10303	-	410241 to 410304
Actual module list (max. 32 modules per station × 2 registers for module-ID)	0x2A00 to 0x2A3F	10752 to 10815	-	410753 to 410816
Slot-related address assignment				
Process data inputs (max. 32 modules per station × 32 registers for module-ID)	0x8000 to 0x8400			
slot 1	0x8000	32768	-	432769
slot 2	0x8020	32800	-	432801
slot 3	0x8040	32832	-	432833
...
slot 32	0x83E0	33760		433761
Process data outputs (max. 32 modules per station × 32 registers for module-ID)	0x9000 to 0x9400			
slot 1	0x9000	36864	-	436865
slot 2	0x9020	36896	-	436897
slot 3	0x9040	36928	-	436929
...
slot 32	0x93E0	37856	-	437857

Table 6-4:
Mapping of
BL20-E-GW-EN
Modbus regis-
ters (holding
registers)

Description	Hex	Decimal	5-digit	Modicon
Diagnostics (max. 32 modules per station × 32 registers for module-ID)				
slot 1	0xA000	40960	-	440961
slot 2	0xA020	40991	-	440992
slot 3	0xA040	41023	-	441024
...
slot 32	0xA3E0	41983	-	441984
Parameters (max. 32 modules per station × 32 registers for module-ID)				
slot 1	0xB000	45056	-	445057
slot 2	0xB020	45088	-	445089
slot 3	0xB040	45120	-	445121
...
slot 32	0xB3E0	46048	-	446049

6.3.1 Structure of the packed in-/ output process data

In order to assure a largely efficient access to the process data of a station, the module data are consistently packed and mapped to a coherent register area.

The I/O-modules are divided into digital and intelligent modules (analog modules, serial interfaces).



Note

For the data mapping, the BL20-1SWIRE-modules are not considered as intelligent modules. Their process data is mapped into the register area for the digital in- and output modules

Both module types are mapped in separate register ranges.

The data mapping always starts with the mapping of the intelligent modules. Each module occupies as many Modbus registers as necessary, depending on its data width. At least one register is occupied. A RS232-module, for example, occupies 4 consecutive registers (8 bytes) in the input and in the output area.

The data byte arrangement is done according to the physical order in the station, from the left to the right.

The data of the intelligent modules are followed by the data of the digital modules, also structured according to their physical appearance in the station. The Modbus registers for the digital data are filled up to 16 bit. This means on the one hand that one Modbus register can contain data of different digital modules and on the other hand that the data of one digital module can be distributed over multiple registers. Bit 0 of a digital module is thus not necessarily located on a word limit.



Note

An example in [chapter 7, page 7-16ff.](#) describes the data mapping.

Additionally, the software I/O-ASSISTANT offers the possibility to create a mapping table for every station.

Packed input process data

- input register area: **0x0000** to **0x01FF**

0x0000			0x01FF
intelligent modules, input data	digital Input modules	status/ diagnosis	free



Note

Independent of the I/O-configuration, an access to all 512 registers is always possible. Registers that are not used send "0".

Status/ diagnosis

The area "status/diagnosis" comprises a maximum of 9 registers.

The first register contains a common gateway-/station-status.

The following registers (max. 8) contain a group diagnostic bit for each I/O-module which shows whether a diagnostic message is pending for the relevant module or not.

Status/ diagnosis	
n + 0x0000	n + 0x0008
Gateway status (reg. 100Ch)	group diagnosis I/O-modules 0...127 (register 0x1018 to 0x101F)

Packed output process data

- output register area: **0x0800** to **0x09FF**

0x0800		0x09FF
intelligent modules, output data	Digital output modules	free



Note

Independent of the I/O-configuration, an access to all 512 registers is always possible. Registers that are not used send "0" answering a read access, write accesses are ignored.

Data width of the I/O-modules in the modbus-register area

The following table shows the data width of the BL20-I/O-modules within the modbus register area and the type of data alignment.

Table 6-5:
Data width of
the I/O-modules

Module	Process input	Process output	Alignment
- digital inputs			
BL20-2DI-x	2 Bit	-	bit by bit
BL20-4DI-x	4 Bit	-	bit by bit
BL20-E-8DI-x	8 Bit	-	bit by bit
BL20-16DI-x	16 Bit	-	bit by bit
BL20-E-16DI-x	16 Bit	-	bit by bit
BL20-32DI-x	32 Bit	-	bit by bit
- digital outputs			
BL20-2DO-x	-	2 Bit	bit by bit
BL20-4DO-x	-	4 Bit	bit by bit
BL20-E-8DO-x	-	8 Bit	bit by bit
BL20-16DO-x	-	16 Bit	bit by bit
BL20-E-16DO-x	-	16 Bit	bit by bit
BL20-32DO-x	-	32 Bit	bit by bit
- Analog input modules			
BL20-1AI-x	1 word		word by word
BL20-2AI-x	2 word		word by word
BL20-2AIH-I	12 word		word by word
BL20-4AI-x	4 word		word by word
BL20-E-4AI-TC	4 word		word by word
BL20-E-8AI-U/I-4AI-PT/NI	8 word		word by word
- Analog outputs			
BL20-1AO-x		1 word	word by word
BL20-2AO-x		2 word	word by word
BL20-2AOH-I	8 word	2 word	word by word
BL20-E-4AO-U/I		4 word	word by word

Table 6-5: Data width of the I/O-modules	Module	Process input	Process output	Alignment
A The process data of the SWIRE-modules is mapped into the register area for the digital in- and output modules.	– Technology modules			
	BL20-1RSxxx	4 word	4 word	word by word
	BL20-1SSI	4 word	4 word	word by word
	BL20-E-2CNT-2PWM	12 word	12 word	word by word
	BL20-E-SWIRE A	4 word	4 word	word by word
	BL20-2RFID-S	12 word	12 word	word by word
	– Power distribution modules			
	BL20-BR-x	-		
BL20-PF-x	-			

6.3.2 Register 0x100C: Gateway status

This register contains a general gateway/ station status.

Table 6-6:
Register 100Ch:
Gateway status

Bit	Name	Description
Gateway		
15	reserved	-
14	Force Mode Active Error	The Force Mode is activated, which means, the actual output values may no match the ones defined and sent by the field bus.
13	reserved	-
12	Modbus Wdog Error	A timeout occurred in the modbus-communication.
Module bus		
11	I/O Cfg Modified Error	The I/O-configuration has be changed and is no longer compatible.
10	I/O Communication Lost Error	No Communication on the module bus.
Voltage errors		
9	U_{sys} too low	System supply voltage too low (< 18 V DC).
8	U_{sys} too high	System supply voltage too high (> 30 V DC).
7	U_L too low	Load voltage too low (< 18 V DC).
6	reserved	-
5	reserved	-
4	reserved	-
Warnings		
3	I/O Cfg Modified Warning	The station configuration has changed.
0	I/O Diags Active Warning	At least one I/O-module sends active diagnosis.

6.3.3 Register 0x1130h: Modbus-Connection-Mode

This register defines the behavior of the Modbus connections:

Table 6-7: Register 0x1130h: Modbus- Connection- Mode	Bit	Name	Description
	15 to 2	reserved	
A default setting	1	MB_ImmediateWritePermission	<ul style="list-style-type: none"> – 0: With the first write access, a write authorization for the respective Modbus-connection is requested. If this request fails, an exception response with exception-code 01h is generated. If the request is accepted, the write access is executed and the write authorization remains active until the connection is closed. A – 1: The write authorization for the respective Modbus-connection is already opened during the establishment of the connection. The first Modbus-connection thus receives the write authorization, all following connections don't (only if bit 0 = 1).
	0	MB_OnlyOneWritePermission	<ul style="list-style-type: none"> – 0: all Modbus-connections receive the write authorization A – 1: only one Modbus-connection can receive the write permission. A write permission is opened until a Disconnect. After the Disconnect the next connection which requests a write access receives the write authorization.

6.3.4 Register 0x1131: Modbus-Connection-Timeout

This register defines after which time of inactivity a Modbus-connection is closed through a Disconnect.

6.3.5 Register 0x113C and 0x113D: Restore Modbus-connection parameters

Register 0x113C and 0x113D are used to reset the parameter registers 0x1120 and 0x1130 to 0x113B to default.

For this purpose, write 0x6C6F to register 0x113E. To activate the reset of the registers, write 0x6164 ("load") within 30 seconds in register 0x113D.

Both registers can also be written with one single request using the function codes FC16 and FC23.

The service resets the parameters without saving them. This can be achieved by using a following "save" service.

6.3.6 Register 0x113E and 0x113F: „Save Modbus-Connection-Parameters“

Registers 0x113E and 0x113F are used for permanent storing the parameters in registers 0x1120 and 0x1130 to 0x113B.

For this purpose, write 0x7361 to register 0x113E. To activate the saving of the registers, write 0x7665 ("save") within 30 seconds in register 0x113F.

Both registers can also be written with one single request using the function codes FC16 and FC23.

6.3.7 Register 0x1140: Disable protocol



Note

This register is only valid for BL20-E-GW-EN with multiprotocol-functionality, meaning, for gateways with **VN 03-00** and higher.

Bit 7	Bit 6	Bit 5	Bit 4	Bit 3	Bit 2	Bit 1	Bit 0
-	-	-	-	-	PROFINET deactivate	reserved	EtherNet/IP deactivate
Bit 15	Bit 14	Bit 13	Bit 12	Bit 11	Bit 10	Bit 9	Bit 8
Web-Server deactivate	-	-	-	-	-	-	-

6.3.8 Register 0x1141: Active protocol



Note

This register is only valid for BL20-E-GW-EN with multiprotocol-functionality, meaning, for gateways with **VN 03-00** and higher.

Bit 7	Bit 6	Bit 5	Bit 4	Bit 3	Bit 2	Bit 1	Bit 0
-	-	-	-	-	PROFINET active	Modbus TCP active	EtherNet/IP active
Bit 15	Bit 14	Bit 13	Bit 12	Bit 11	Bit 10	Bit 9	Bit 8
Web-Server active	-	-	-	-	-	-	-

6.3.9 Register 0x2000 bis 0x207F: The Service-Object

The service-object is used to execute one-time or acyclic services. It is an acknowledge service which may serve, for example, to parameterize an I/O-module.

0x2000	0x2080	0x20FF
service request area	service response area	

The service request area allows write access, the service response area only read access.

- service request area

0x2000	0x2001	0x2002	0x2003	0x2004	0x2005	0x207F
Service-number	reserved	Service-Code	Index/ addr	Data-Reg-Count	optional data (0...122 registers)	

The register **service no.** in the request area can contain a user defined value which is deleted after the execution of the service.

The register **service code** specifies which service is requested.

The register **index/addr** is optional and the meaning depends on the particular service.

The register **data-reg-count** contains, depending on the service, the number (0 to 122) of the transferred or of the requested data registers.

Depending on the service, the **optional data area** can contain additional parameters and/or other data to be written.

- Service-response-area

0x2080	0x2081	0x2082	0x2083	0x2084	0x2085	0x20FF
Service-number	result	Service-Code	Index/ Addr	Data-Reg-Count	optional data (0...122 registers)	

After the execution of a request, the registers **service-no.**, **service code** and **index/addr** in the response area contain a copy of the values in the request area.



Note

The service no. is thus used for a simple handshake on the application level. The application increases the service no. with every request. The service is blocked, until the service number in the request area matches the service number in the response area.

The register **result** shows whether the execution was successful or not.

The register **data-reg-count** contains the number of data registers (0 to 122).

The **optional data area** can contain, depending on the service, the requested data.

Supported service numbers:

Table 6-8:
Supported
service numbers

Service-Code	Meaning
0x0000	no function
0x0003	indirect reading of registers
0x0010	indirect writing of registers

A service request may have the following results:

Table 6-9:
results of the
service request

Service-Code	Meaning
0x0000	error free execution of service
0xFFFE	service parameters incorrect/ inconsistent
0xFFFF	service code unknown



Note

The services "indirect reading of registers" and "indirect writing of registers" offer an additional possibility to access any Modbus register.

Current Modbus-masters support only a limited number of register-areas that can be read or written during the communication with a Modbus-server. These areas can not be changed during operation.

In this case, the services mentioned above enables non-cyclic access to registers.

Indirect reading of registers

1...122 (Count) Modbus-registers are read starting with address x (Addr).

■ service-request

0x2000	0x2001	0x2002	0x2003	0x2004	0x2005	0x207F
Service-number	0x0000	0x0003	Addr	Count	no meaning	

■ service response

0x2080	0x2081	0x2082	0x2083	0x2084	0x2085	0x20FF
Service-number	result	0x0003	Addr	Count	register contents	

Indirect writing of registers

1 to 122 (Count) Modbus-registers are read, starting with address Addr.)

- service-request

0x2000	0x2001	0x2002	0x2003	0x2004	0x2005	0x207F
Service-number	0x0000	0x0010	Addr	Count	register contents	

- service response

0x2080	0x2081	0x2082	0x2083	0x2084	0x2085	0x20FF
Service-number	result	0x0010	Addr	Count	no meaning	

6.4 Bit areas: mapping of input-discrete- and coil-areas

The digital in- and outputs can be read and written (for outputs) as registers in the data area of the packed in- and output process data.



Note

In the packed process data, the digital I/O data are stored following the variable in- and output data area of the intelligent modules, which means they are stored with a variable offset, depending on the station's I/O-configuration.

In order to set for example a single output (single coil), the following functions are available for reading and writing single bits:

- FC1 („Read Coils“)
- FC2 („Read Discrete Inputs“)
- FC5 („Write Single Coil“)
- FC15 („Write Multiple Coils“)

Data mapping in the input-discrete- and coil-areas:

- Mapping Mapping: input-discrete-area
All digital inputs are stored in this area (offset "0").
- Mapping Mapping: Coil-area
All digital outputs are stored in this area (offset "0").

6.5 Error behavior of outputs (watchdog)

In case of a failure of the Modbus communication, the outputs' behavior is as follows, depending on the defined time for the Watchdog ([register 0x1120 \(page 6-7\)](#)):

- watchdog = 0 ms (default)
→ outputs hold the momentary value
- watchdog > 0 ms
→ outputs switch to **0** after the watchdog time has expired



Note

Please observe that changes in the watchdog time have to be saved per save-command (see [Register 0x113E and 0x113F: „Save Modbus-Connection-Parameters“ \(page 6-18\)](#)).



Note

Setting the outputs to predefined substitute values is not possible in Modbus TCP. Eventually parameterized substitute values will not be used.

7 Application example: BL20-E-GW-EN for Modbus TCP (CoDeSys Win V3)

7.1	Used hard-/ software.....	2
7.1.1	Hardware.....	2
7.1.2	Software.....	2
7.2	Network configuration	3
7.3	Programming with CoDeSys	4
7.3.1	Predefined feature sets	4
7.3.2	Creating a new project.....	5
7.3.3	Defining the communication settings.....	7
	– Gateway definition	7
	– Setting the communication path.....	8
7.3.4	Adding the Ethernet Adapter	9
7.3.5	Adding the Modbus master	10
7.3.6	Adding a Modbus TCP slave.....	11
7.3.7	Programming (example program).....	13
	– Small example program	13
7.3.8	CoDeSys: Global variables.....	14
	– Global variable list	14
7.3.9	Modbus channels.....	15
	– Modbus data mapping	16
	– Setting the Modbus-channels (examples) and data mapping.....	18
7.3.10	Building, login and start.....	26
7.3.11	Reading out the process data	28
7.3.12	Diagnosis evaluation.....	29
	– Evaluation of the Status word of the BL20-Station (%IW1)	29
	– Evaluation of the group diagnosis.....	30
	– Evaluation of the module diagnosis information.....	32

7.1 Used hard-/ software

7.1.1 Hardware

- BL20-E-GW-EN, VN 03-00 (IP-address 192.168.1.16)
 - BL20-2DI-24VDC-P
 - BL20-4DI-24VDC-P
 - BL20-1AI-U(-10/0...+10VDC)
 - BL20-2AI-THERMO-PI
 - BL20-2DO-24VDC-0.5A-P
 - BL20-E-8DO-24VDC-0.5A-P

7.1.2 Software

- CoDeSys 3.4, SP3, Patch 1
- PLC:
CoDeSys Control Win V3 (3.4.3.10)

7.2 Network configuration

BL20-stations are delivered in the address-mode "PGM-DHCP" and can be reached using IP-address **192.168.1.254** .



Note

In order to build up the communication between the BL20-station and a PLC/ PC or a network interface card, both devices have to be hosts in the same network.

To achieve this, you have either

- to adjust the gateway's IP address via BootP, DHCP etc. for integrating it into your own network (for detailed information about the different possibilities for address setting, please read [chapter 3.5, Address assignment, page 3-15](#).

or

- to change the IP address of the used PC or network interface card (for detailed information, please read the [Changing the IP address of a PC/ network interface card, page 13-16](#).

7.3 Programming with CoDeSys

Open CoDeSys via "Start → All programs → 3S CoDeSys → CoDeSys → CoDeSys V 3.4".

7.3.1 Predefined feature sets

In this example, CoDeSys is run with the "Professional feature set" not with the "Standard feature set". This setting has influence on different CoDeSys functions and can be changed via "Tools → Options..." in the "Features" under "Predefined feature sets...". For further information concerning this topic, please read the CoDeSys online help.

Figure 7-1:
Predefined feature sets

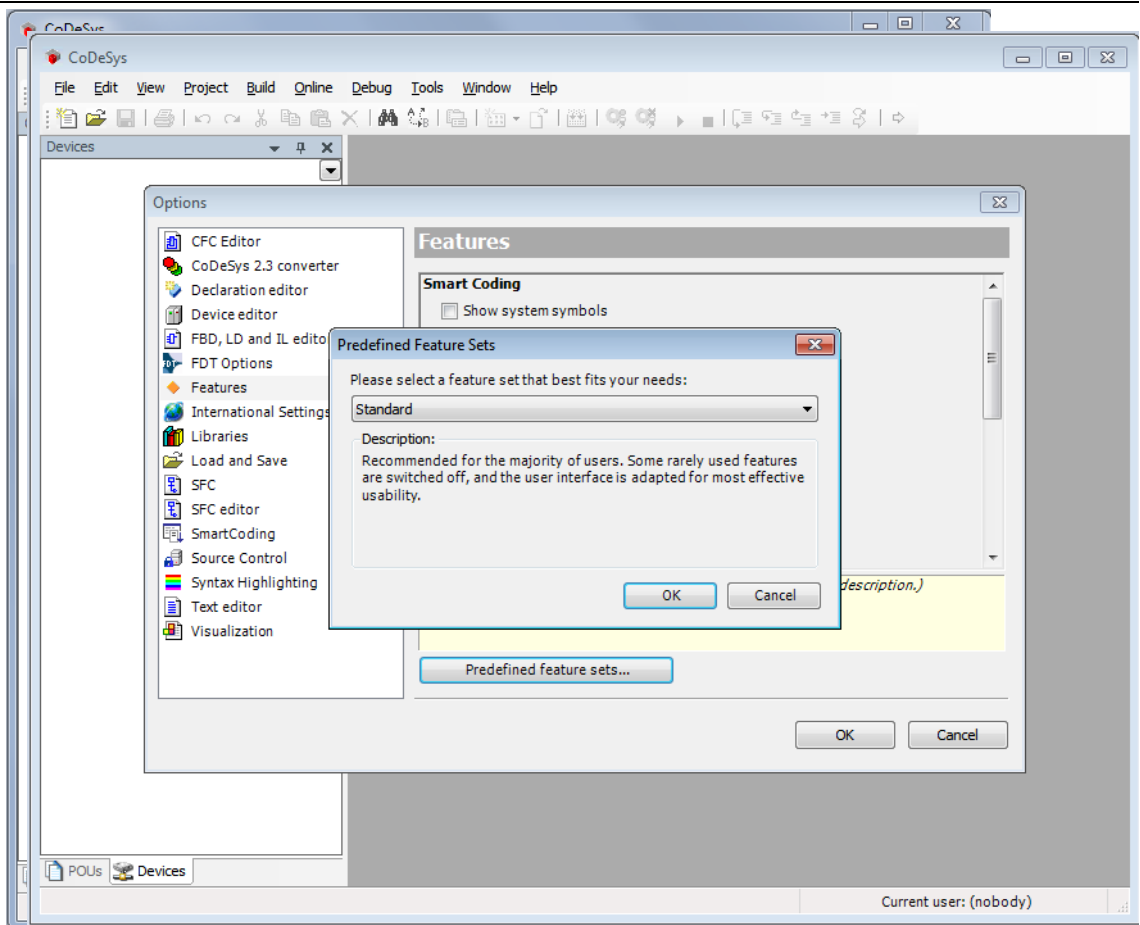

7.3.2 Creating a new project

- 1 Create a new CoDeSys-project using the "File → New project" command.

Figure 7-2:
New project

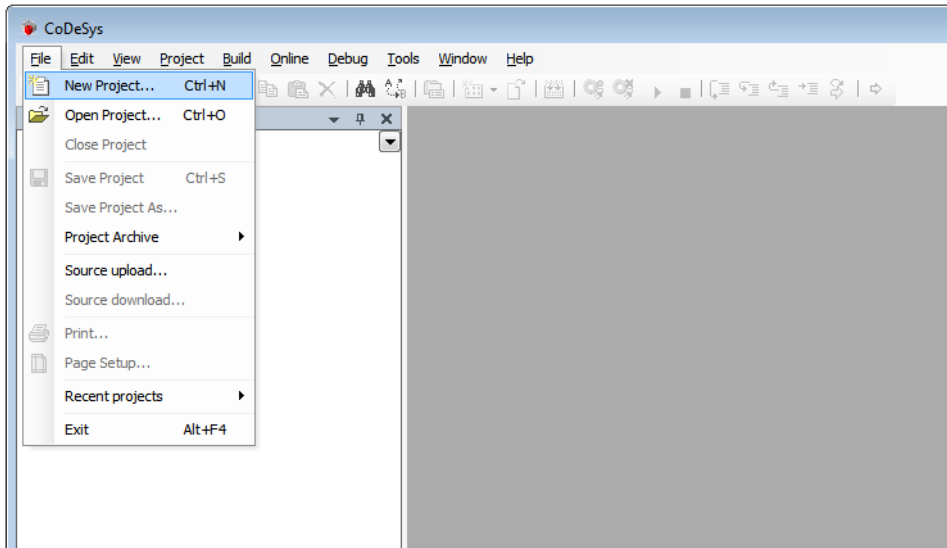

- 2 Select "Standard project" and define a project name.

Figure 7-3:
Standard project

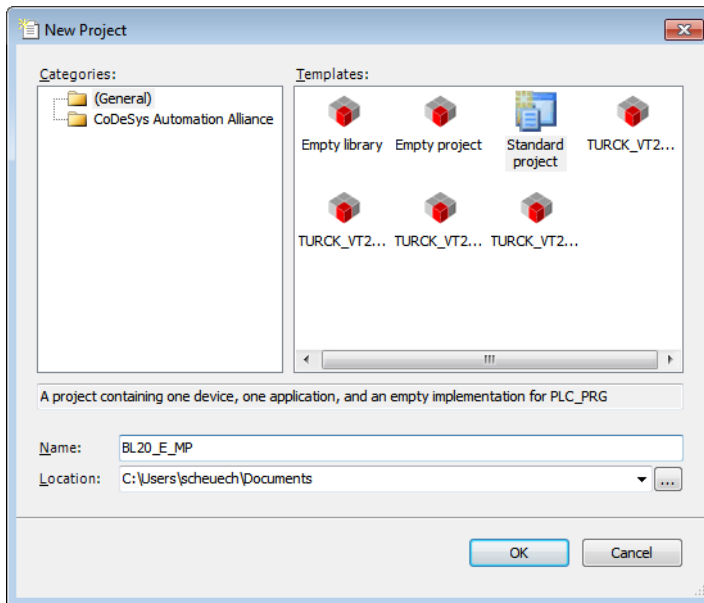

Application example: BL20-E-GW-EN for Modbus TCP (CoDeSys Win V3)

- 3 Select the PLC used in the project.
In this example, the CoDeSys Control Win V3 is used.
- 4 Please define also your preferred programming language.
In this example, Structured Text is used.

Figure 7-4:
Selection of
CoDeSys
Control Win V3

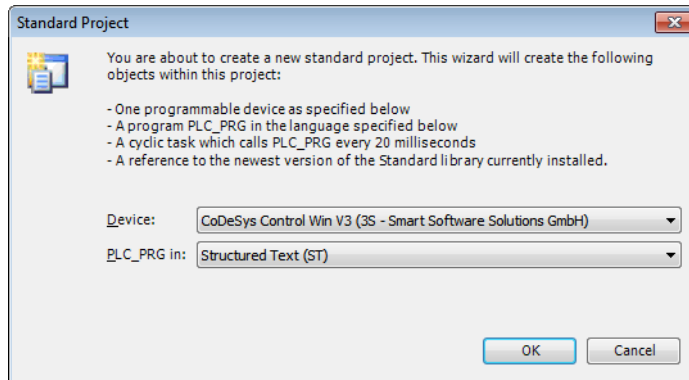

- 5 The new project is created.
- 6 In CoDeSys, the project tree is build up as follows:

Figure 7-5:
Project tree

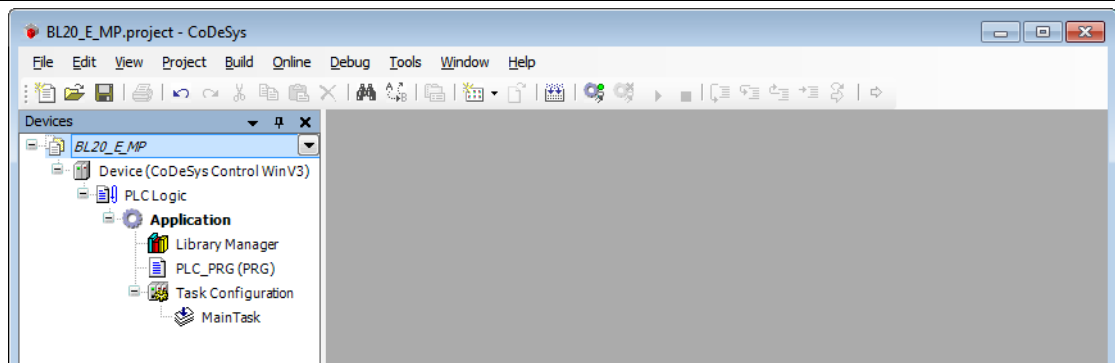

Note

If the window "devices" should not be displayed, it can be activated via "View → Devices".

7.3.3 Defining the communication settings

Double-clicking the "Device (CoDeSys Control Win V3)" opens the corresponding editors.

The communication path (Gateway) to the HMI is defined in the "Communication Settings" tab.

Gateway definition

- 1 Use the "Add gateway"-button to open the dialog box "Gateway" and, where necessary, assign a new gateway name.
- 2 Keep the setting "localhost" or define an IP-address for the gateway instead.
When using the setting "localhost", the CoDeSys-communication-gateway of the PC, on which this CoDeSys-installation is running, is used as programming interface.

Figure 7-6:
Communication settings

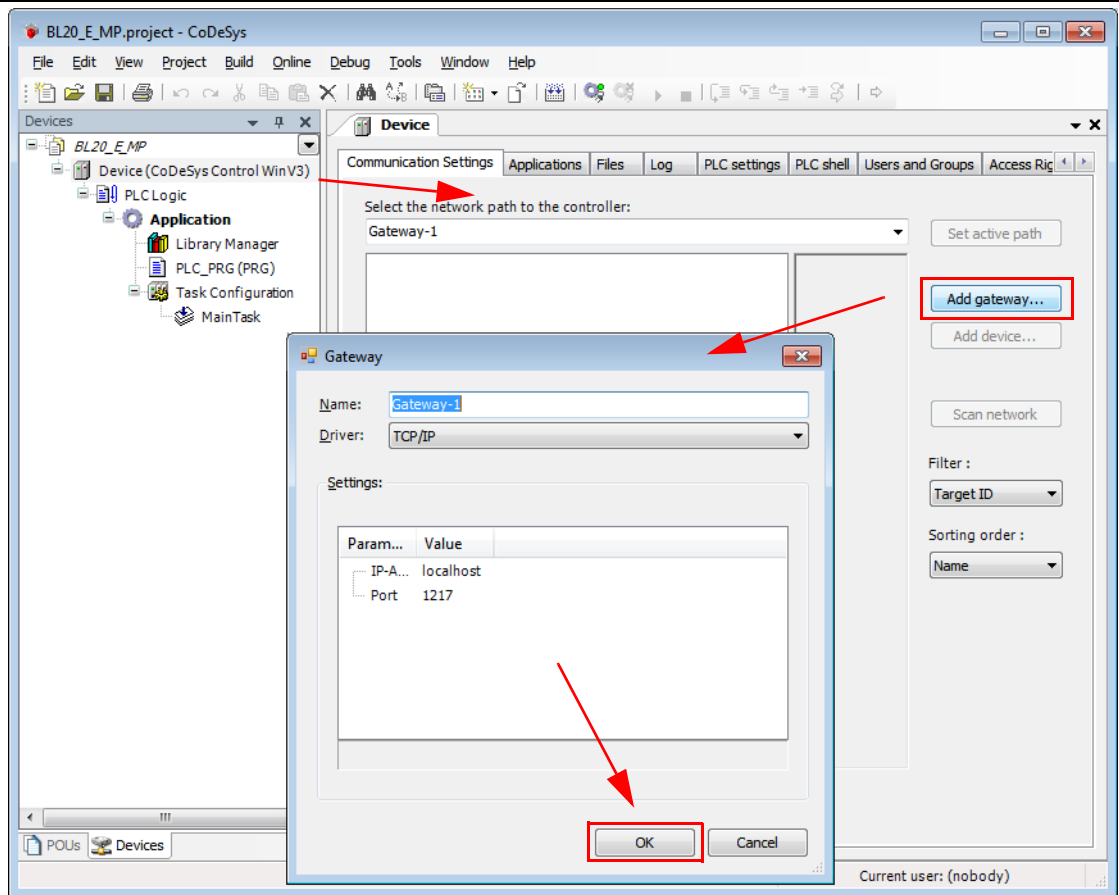

Setting the communication path

- 1 Mark the gateway and scan the network via the respective button.
- 2 The network card of your PC will be found and set as active path.

Figure 7-7:
Setting the communication path

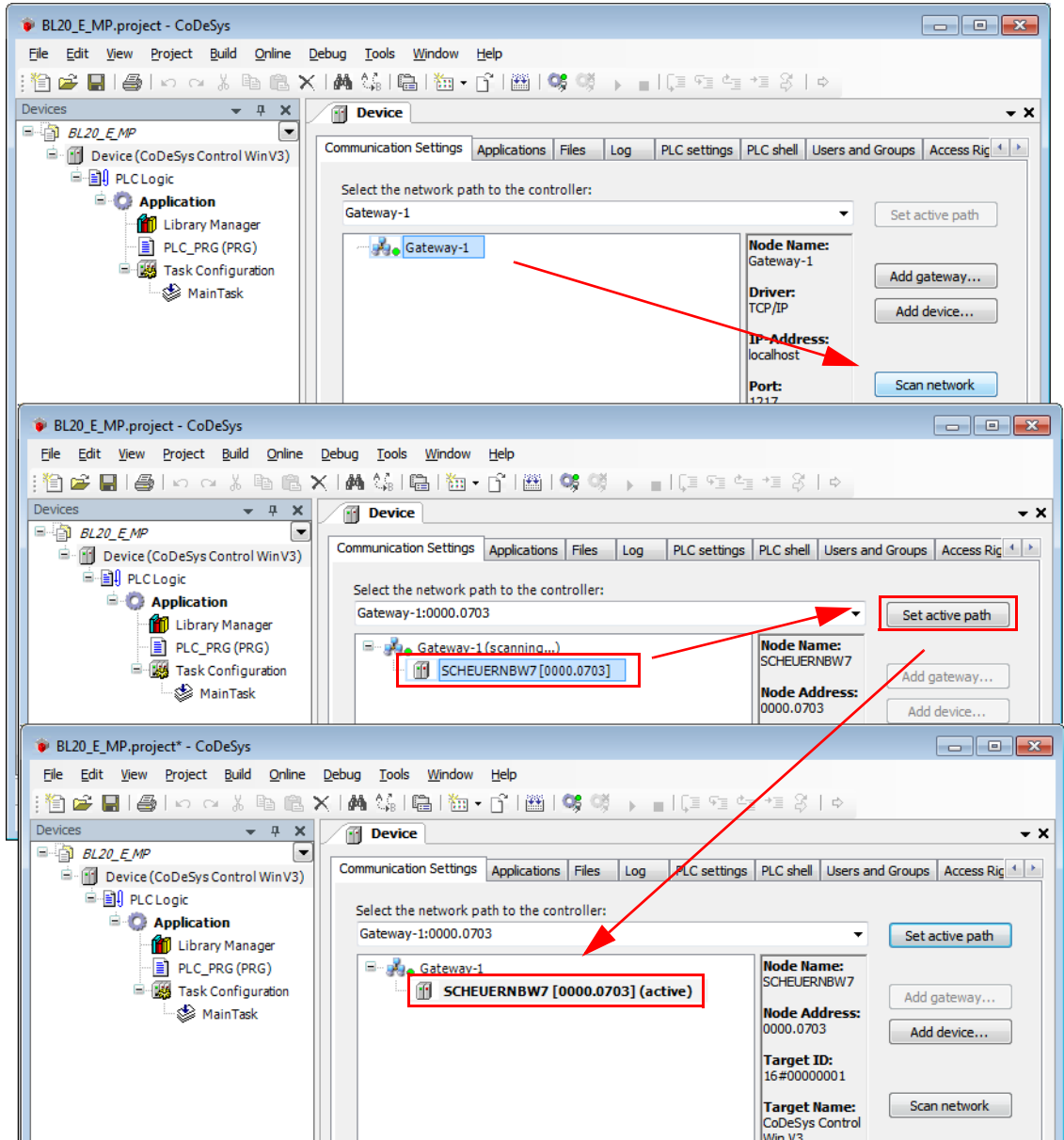

7.3.4 Adding the Ethernet Adapter

Open again the context menu by right-clicking the Device entry. In the dialog "Add Device" select the 3S Ethernet Adapter under "fieldbuses → Ethernet Adapter" and add it to the project tree.

Figure 7-8: Adding the Ethernet Adapter as device

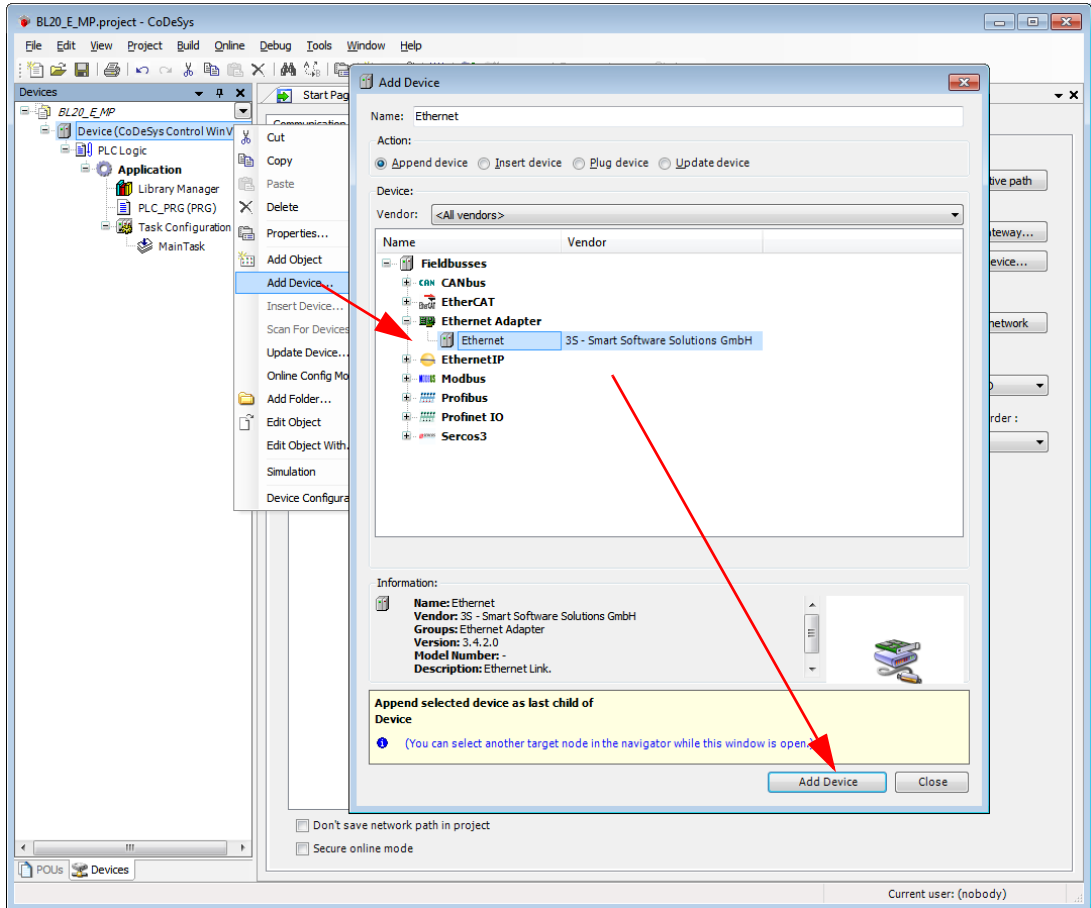

7.3.5 Adding the Modbus master

A right-click on the Ethernet-master opens the context menu. Select "Add Device" and add the Modbus TCP-master to the network.

Figure 7-9:
Adding the
Modbus master

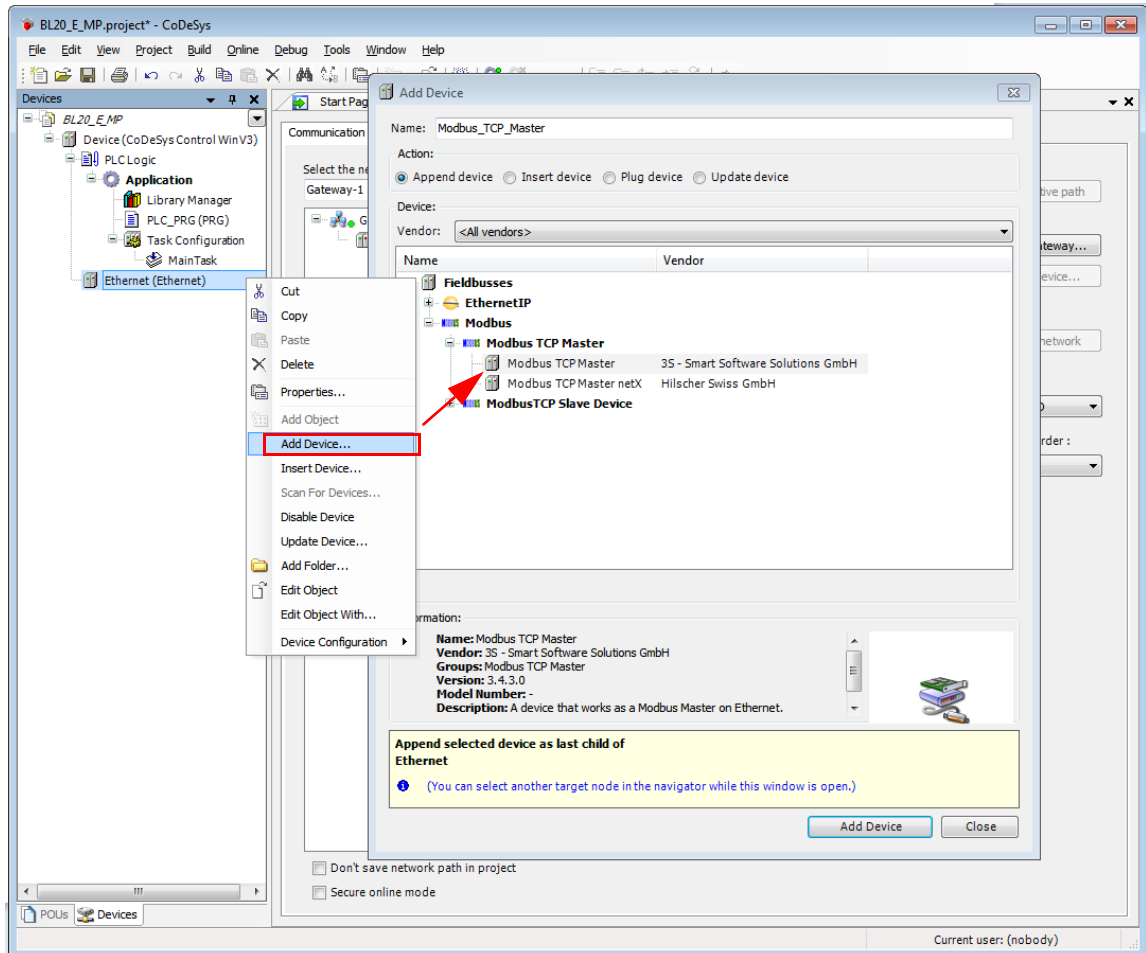

7.3.6 Adding a Modbus TCP slave

- 1 Now, add the Modbus TCP slaves to the project and rename them if necessary.

Figure 7-10:
Selecting a slave

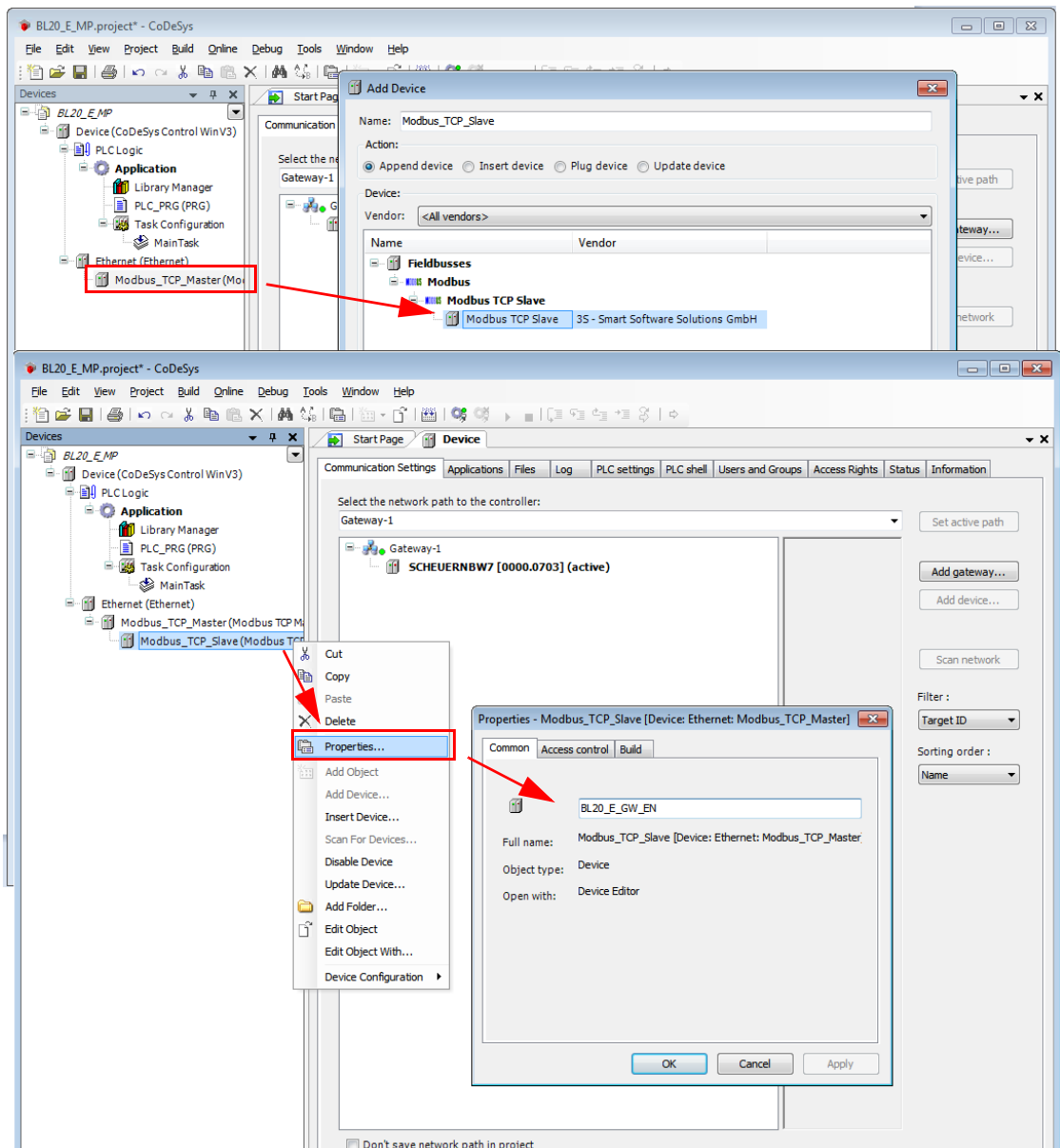

Application example: BL20-E-GW-EN for Modbus TCP (CoDeSys Win V3)

- 2 Again, a double-click onto the slave in the project tree opens the respective editors.
- 3 In the "Modbus TCP Slave"-tab, set the nodes IP-address (in this example: address **192.168.1.16**). All other settings can be kept.

Figure 7-11:
Setting the IP
address at the
slave

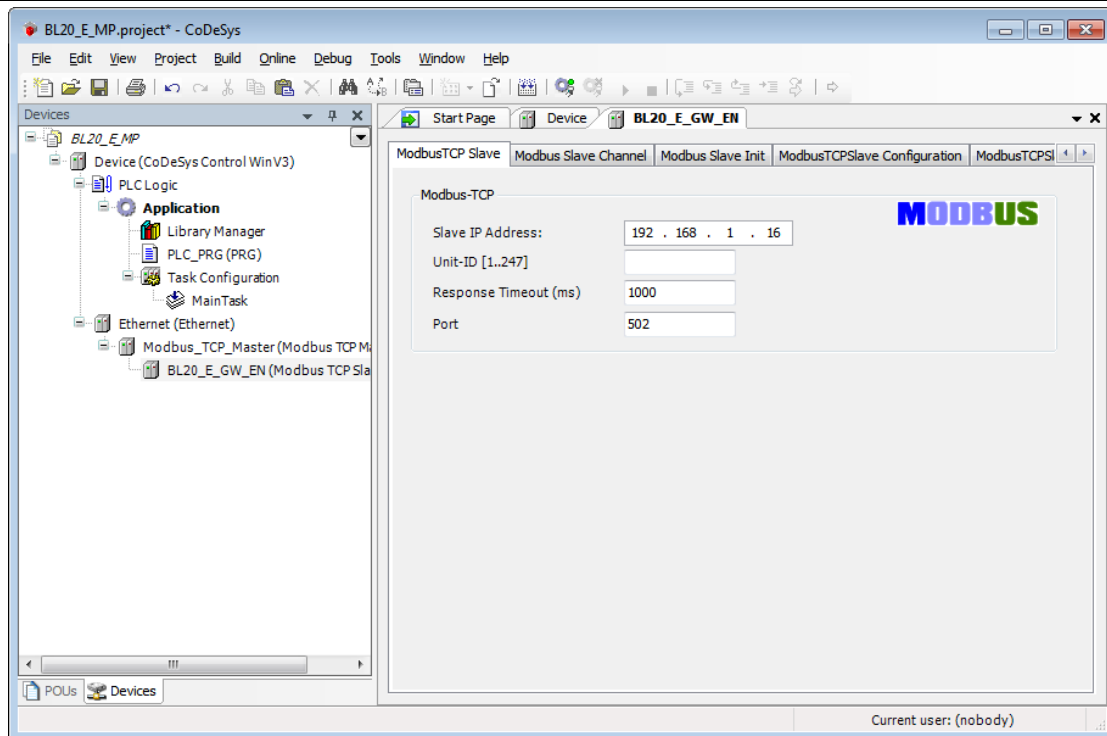

7.3.7 Programming (example program)

The programming is done under PLC-PRG in the project tree. This example is programmed in Structured Text (ST) as defined under [Creating a new project \(page 7-5\)](#).

Small example program

- 1 The counter counts
- 2 Counter-reset via setting the variable "xReset" (BOOL) to "1".
"xReset" has been defined in the global variables (see also page [page 7-14](#))



Note

The status of process values is only shown in the process image if a program refers to them or if the function "Always update variables" in the "ModbusTCP Slave I/O Mapping" (see „Reading out the process data“, [page 7-28](#)) is enabled.

Figure 7-12:
Example program

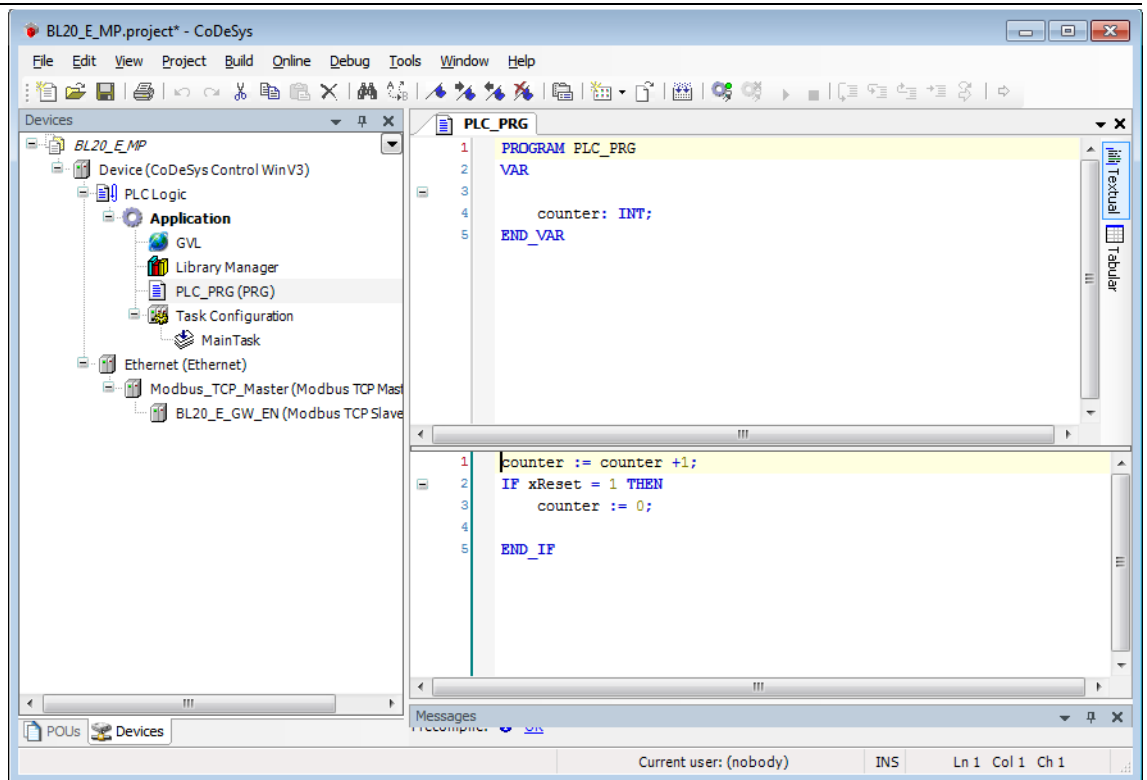

7.3.8 CoDeSys: Global variables

Global variables are defined either in the Global Variable List (see [page 7-14](#)) or directly in the I/O Mappings of the single stations.

Figure 7-13:
Example for
the definition of
a global vari-
able

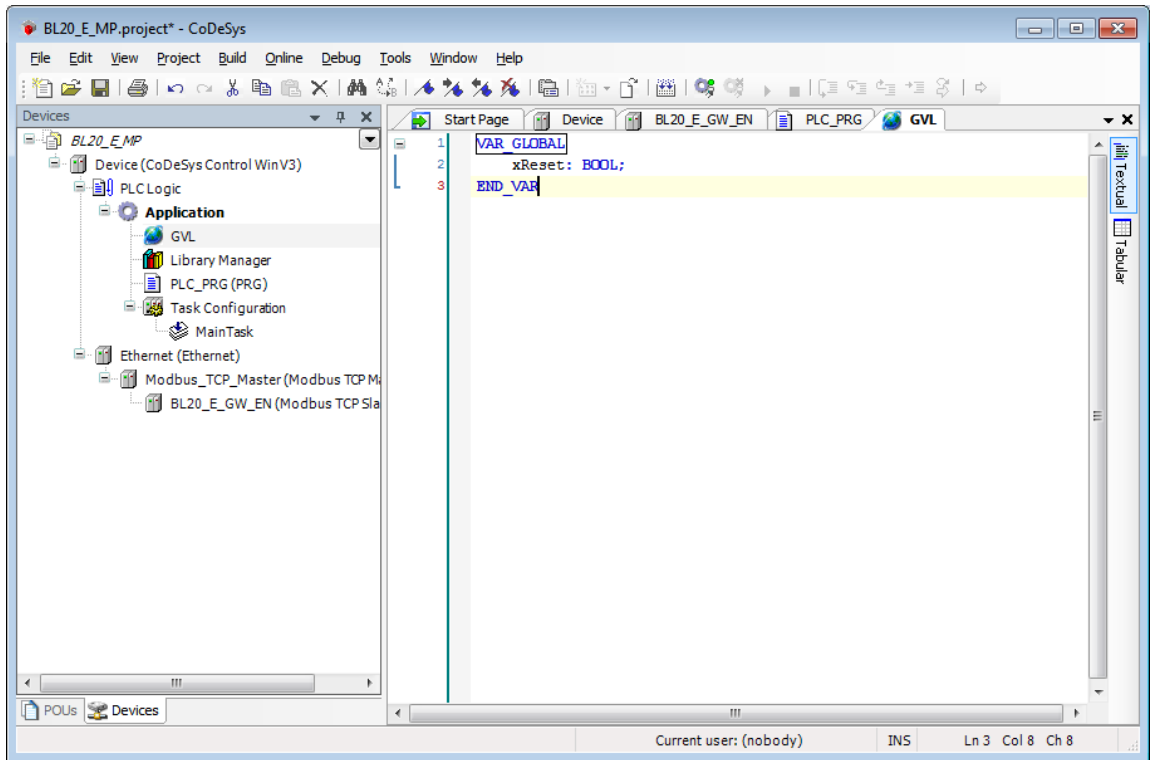

Global variable list

The creation of a "Global Variable List" is possible, too:
right-click to "APPL → Add object → Global Variable List".

Define the global variables The global variables are also automatically exported when building the project, if they have been chosen for export in the symbol configuration. (see also [Predefined feature sets](#) [Figure 7-1](#); [page 7-4](#)).

7.3.9 Modbus channels

The communication between Modbus TCP master and Modbus slaves is realized through defined Modbus channels.

These channels are set in the register-tab "Modbus Slave Channel" using the "Add Channel..." button.

The process data of a slave can then be monitored under "ModbusTCP Slave I/O Mapping" (see 7.3.11, „Reading out the process data“, page 7-28)

Figure 7-14: Setting the Modbus channels, examples

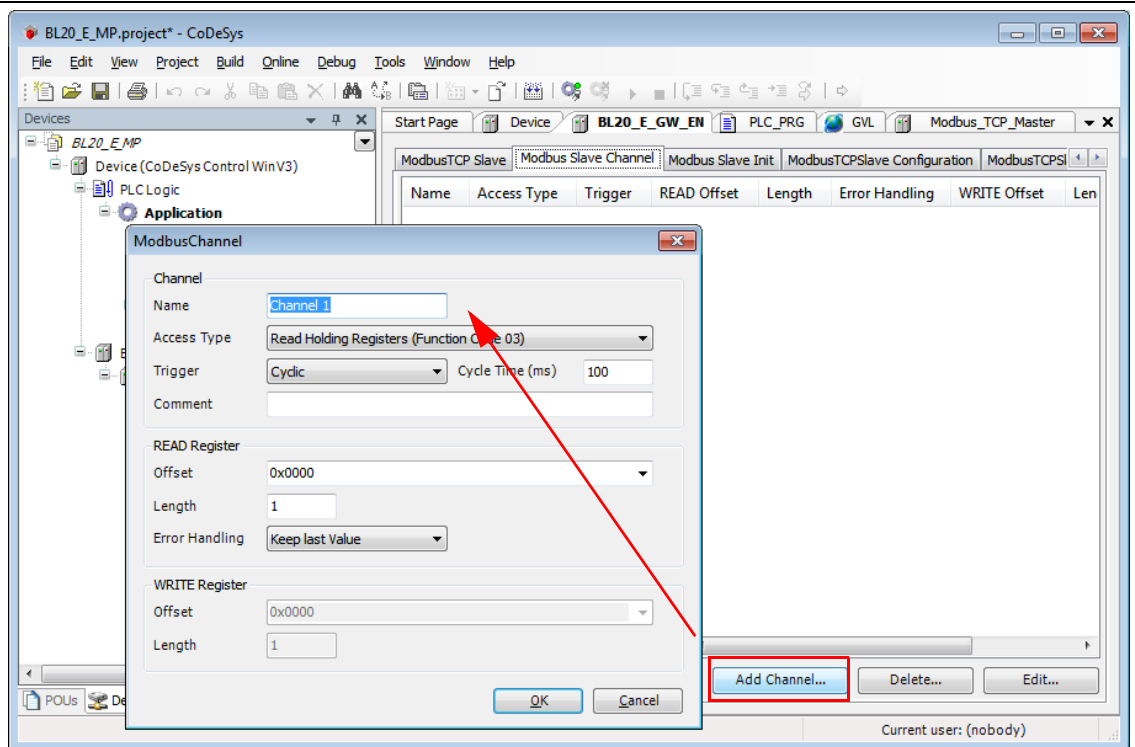

The Modbus communication channels are defined by:

- "Access Type":
Modbus function code, which defines the access method (bit- or word wise, read or write).
- "READ Register" or "WRITE Register" → "Offset":
Specification of the start address for the Modbus Slave's register that has to be read or written. These specifications have to be taken from the slave's Modbus documentation!

Modbus data mapping

The mapping for the input and output data of a BL20-Modbus-station depends on it's configuration. The TURCK-software "I/O-ASSISTANT (FDT/DTM)" offer the possibility to create a Modbus-report for each Modbus-station, which shows the in-and output data mapping as well as the parameter- and diagnostic data mappings for the respective station.

Modbus mapping (I/O-ASSISTANT)

Figure 7-15:
Modbus report -
Mapping of in-
and output data

2. Modbus report

2.1. Station description

Station address: 192.168.1.112

Adr./Slot	Name	TAG	Data Size In	Data Size Out
0*	BL20-E-GW-EN (>= VN 03-00)	192.168.1.112/BL20-E-GW-EN (>= VN 03-00)	16 bit	0 bit
1	BL20-2DI-24VDC-P	01/BL20-2DI-24VDC-P	2 bit	0 bit
2	BL20-4DI-24VDC-P	02/BL20-4DI-24VDC-P	4 bit	0 bit
3	BL20-1AI-U(-10/0...+10VDC)	03/BL20-1AI-U(-10/0...+10VDC)	16 bit	0 bit
4	BL20-2AI-THERMO-PI	04/BL20-2AI-THERMO-PI	32 bit	0 bit
5	BL20-2DO-24VDC-0.5A-P	05/BL20-2DO-24VDC-0.5A-P	0 bit	2 bit
6	BL20-E-8DO-24VDC-0.5A-P	06/BL20-E-8DO-24VDC-0.5A-P	0 bit	8 bit
Local I/O data incl. status/control			4 Words	1 Word
Summarized diagnostics			1 Word	0 Words
Total size for in/out data rounded on full words			6 Words	1 Word

*For detailed information about status/control word see online help.

2.2. I/O map for input data

Register		Bit position															
Hex	Dec	15	14	13	12	11	10	9	8	7	6	5	4	3	2	1	0
0x0000	0000	03.15	03.14	03.13	03.12	03.11	03.10	03.09	03.08	03.07	03.06	03.05	03.04	03.03	03.02	03.01	03.00
0x0001	0001	04.15	04.14	04.13	04.12	04.11	04.10	04.09	04.08	04.07	04.06	04.05	04.04	04.03	04.02	04.01	04.00
0x0002	0002	04.31	04.30	04.29	04.28	04.27	04.26	04.25	04.24	04.23	04.22	04.21	04.20	04.19	04.18	04.17	04.16
0x0003	0003	-	-	-	-	-	-	-	-	-	-	02.03	02.02	02.01	02.00	01.01	01.00
*0x0004	0004	GW.15	GW.14	GW.13	GW.12	GW.11	GW.10	GW.09	GW.08	GW.07	GW.06	GW.05	GW.04	GW.03	GW.02	GW.01	GW.00
**0x0005	0005	-	-	-	-	-	-	-	-	-	-	M05	M04	M03	M02	M01	M00

Description: 1.Column=Register address, n. Column=Modul number.bitposition

*) GW: gateway status-/diagnostics bits

**) M: module diagnostics (1 bit for each module)

Process input data: 6 Words

2.3. I/O map for output data

Register		Bit position															
Hex	Dec	15	14	13	12	11	10	9	8	7	6	5	4	3	2	1	0
0x0800	2048	-	-	-	-	-	-	06.07	06.06	06.05	06.04	06.03	06.02	06.01	06.00	05.01	05.00

Description: 1.Column=Register address, n. Column=Modul number.bitposition

Process output data: 1 Word

Figure 7-16:
Modbus report -
Mapping of
parameter and
diagnostic data

2.4. Map for parameter data

Station report

Register	Bit pos.	Length	Slot	Module	Parameter	Value range
B040	0	1	3	BL20-1AI-U(-10/0...+10VDC)	voltage mode	0 : 0..10V 1 : -10..+10V
B040	1	1	3	BL20-1AI-U(-10/0...+10VDC)	value representation	0 : Integer (15Bit + sign) 1 : 12Bit (left-justified)
B040	2	1	3	BL20-1AI-U(-10/0...+10VDC)	diagnostics	0 : release 1 : block
B040	3	1	3	BL20-1AI-U(-10/0...+10VDC)	channel	0 : activate 1 : deactivate
B060	0	1	4	BL20-2AI-THERMO-PI	mains suppression	0 : 50Hz 1 : 60Hz
B060	1	1	4	BL20-2AI-THERMO-PI	value representation	0 : Integer (15Bit + sign) 1 : 12Bit (left-justified)
B060	2	1	4	BL20-2AI-THERMO-PI	diagnostic	0 : release 1 : block
B060	3	1	4	BL20-2AI-THERMO-PI	channel	0 : activate 1 : deactivate
B060	4	4	4	BL20-2AI-THERMO-PI	element	0 : Type K, -270..1370°C 1 : Type B, +100..1820°C 2 : Type E, -270..1000°C 3 : Type J, -210..1200°C 4 : Type N, -270..1300°C 5 : Type R, -50..1760°C 6 : Type S, -50..1540°C 7 : Type T, -270..400°C 8 : +/-50mV 9 : +/-100mV 10 : +/-500mV 11 : +/-1000mV
B060	8	1	4	BL20-2AI-THERMO-PI	mains suppression	0 : 50Hz 1 : 60Hz
B060	9	1	4	BL20-2AI-THERMO-PI	value representation	0 : Integer (15Bit + sign) 1 : 12Bit (left-justified)
B060	10	1	4	BL20-2AI-THERMO-PI	diagnostic	0 : release 1 : block
B060	11	1	4	BL20-2AI-THERMO-PI	channel	0 : activate 1 : deactivate
B060	12	4	4	BL20-2AI-THERMO-PI	element	0 : Type K, -270..1370°C 1 : Type B, +100..1820°C 2 : Type E, -270..1000°C 3 : Type J, -210..1200°C 4 : Type N, -270..1300°C 5 : Type R, -50..1760°C 6 : Type S, -50..1540°C 7 : Type T, -270..400°C 8 : +/-50mV 9 : +/-100mV 10 : +/-500mV 11 : +/-1000mV

2.5. Map for diagnostic data

Register	Bit pos.	Length	Slot	Module	Parameter	Value range
A040	0	1	3	BL20-1AI-U(-10/0...+10VDC)	overflow/underrun channel x	0 : 1 : activate
A060	0	1	4	BL20-2AI-THERMO-PI	measurement value range error channel x	0 : 1 : activate
A060	1	1	4	BL20-2AI-THERMO-PI	open circuit channel x	0 : 1 : activate
A060	2	1	4	BL20-2AI-THERMO-PI	no PT1000 sensor(cold j. comp) channel x	0 : 1 : activate
A060	8	1	4	BL20-2AI-THERMO-PI	measurement value range error channel x	0 : 1 : activate
A060	9	1	4	BL20-2AI-THERMO-PI	open circuit channel x	0 : 1 : activate
A060	10	1	4	BL20-2AI-THERMO-PI	no PT1000 sensor(cold j. comp) channel x	0 : 1 : activate
A080	0	1	5	BL20-2DO-24VDC-0.5A-P	short circuit channel x	0 : 1 : activate
A080	1	1	5	BL20-2DO-24VDC-0.5A-P	short circuit channel x	0 : 1 : activate



Note

Detailed information about the modbus registers of the BL20-stations can be found in the descriptions in [chapter 6.3](#).

Setting the Modbus-channels (examples) and data mapping

1 Writing of %QW0 and mapping of the counter value (VAR "Counter", see PLC_PRG, page 7-13) to the output byte of the station (%QW0).

1.1 Write: %QW0

- Access Type:
Write Single Register (function code 06)
- Write Register, Offset:
0x0800 (see below)
The process output data of the station can be found in register 0x0800.

Figure 7-17:
Mapping of output data acc. to Modbus-report

2.3. I/O map for output data

Register		Bit position																
Hex	Dec	15	14	13	12	11	10	9	8	7	6	5	4	3	2	1	0	
0x0800	2048	-	-	-	-	-	-	-	06.07	06.06	06.05	06.04	06.03	06.02	06.01	06.00	05.01	05.00

Description: 1.Column=Register address, n. Column=Modul number.bitposition

Process output data: 1 Word

Figure 7-18:
Modbus channel, counter value, FC06

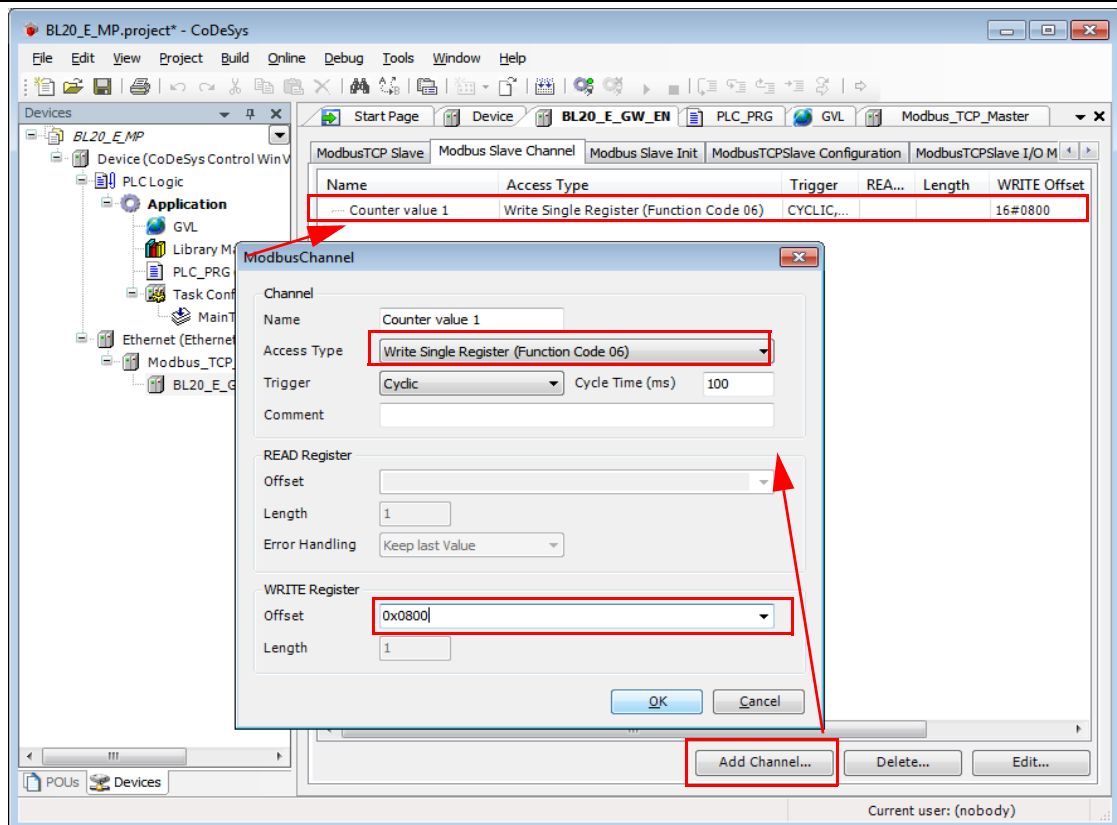

1.2 Mapping: counter value to %QW0

- The mapping of the counter value (VAR "Counter") to the station 's output register is done the the "ModbusTCPSlave I/O Mapping".
Double click the field "variable" in the respective line. Use the "..."-button to open the dialog box "Input Assistant".
- Select the variable to be mapped. As "Counter" been defined in PLC_PRG, see [Programming \(example program\)](#), it can be found there.

Figure 7-19:
Mapping of the
counter value to
%QW0

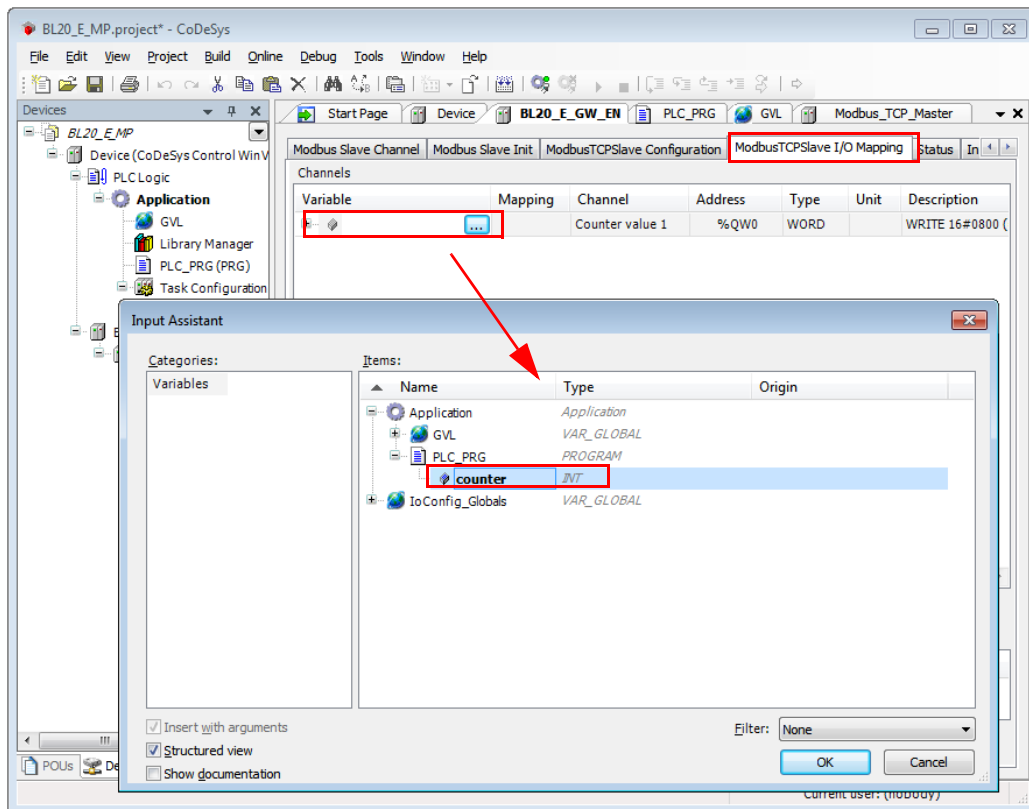

- Confirm with "OK". The counter value is now mirrored to %QW0 of the station and given out.

2 Read:

Bit 0 in register 0x0003 has to be read out
 (→ reset the counter (with „xReset“ = 1))

- 2.1** Read: %IW0
 - Access Type:
Read Holding Registers (function code **03**)
 - Read Register, Offset:
0x0003 (see below)

Figure 7-20:
Mapping of
input data acc.
to Modbus-
report

2. Modbus report

2.1. Station description

Station address: 192.168.1.112

Adr./Slot	Name	TAG	Data Size In	Data Size Out
0*	BL20-E-GW-EN (>= VN 03-00)	192.168.1.112/BL20-E-GW-EN (>= VN 03-00)	16 bit	0 bit
1	BL20-2DI-24VDC-P	01/BL20-2DI-24VDC-P	2 bit	0 bit
2	BL20-4DI-24VDC-P	02/BL20-4DI-24VDC-P	4 bit	0 bit
3	BL20-1AI-U(-10/0...+10VDC)	03/BL20-1AI-U(-10/0...+10VDC)	16 bit	0 bit
4	BL20-2AI-THERMO-PI	04/BL20-2AI-THERMO-PI	32 bit	0 bit
5	BL20-2DO-24VDC-0.5A-P	05/BL20-2DO-24VDC-0.5A-P	0 bit	2 bit
6	BL20-E-8DO-24VDC-0.5A-P	06/BL20-E-8DO-24VDC-0.5A-P	0 bit	8 bit
Local I/O data incl. status/control			4 Words	1 Word
Summarized diagnostics			1 Word	0 Words
Total size for in/out data rounded on full words			6 Words	1 Word

*For detailed information about status/control word see online help.

2.2. I/O map for input data

Register		Bit position															
Hex	Dec	15	14	13	12	11	10	9	8	7	6	5	4	3	2	1	0
0x0000	0000	03.15	03.14	03.13	03.12	03.11	03.10	03.09	03.08	03.07	03.06	03.05	03.04	03.03	03.02	03.01	03.00
0x0001	0001	04.15	04.14	04.13	04.12	04.11	04.10	04.09	04.08	04.07	04.06	04.05	04.04	04.03	04.02	04.01	04.00
0x0002	0002	04.31	04.30	04.29	04.28	04.27	04.26	04.25	04.24	04.23	04.22	04.21	04.20	04.19	04.18	04.17	04.16
0x0003	0003	-	-	-	-	-	-	-	-	-	-	02.03	02.02	02.01	02.00	01.01	01.00
*0x0004	0004	GW.15	GW.14	GW.13	GW.12	GW.11	GW.10	GW.09	GW.08	GW.07	GW.06	GW.05	GW.04	GW.03	GW.02	GW.01	GW.00
**0x0005	0005	-	-	-	-	-	-	-	-	-	-	M05	M04	M03	M02	M01	M00

Description: 1.Column=Register address, n. Column=Modul number.bitposition

*) GW: gateway status-/diagnostics bits

***) M: module diagnostics (1 bit for each module)

Process input data: 6 Words

2.3. I/O map for output data

Register		Bit position															
Hex	Dec	15	14	13	12	11	10	9	8	7	6	5	4	3	2	1	0
0x0800	2048	-	-	-	-	-	-	06.07	06.06	06.05	06.04	06.03	06.02	06.01	06.00	05.01	05.00

Description: 1.Column=Register address, n. Column=Modul number.bitposition

Process output data: 1 Word

Figure 7-21: Modbus channel, read "xReset", FC03

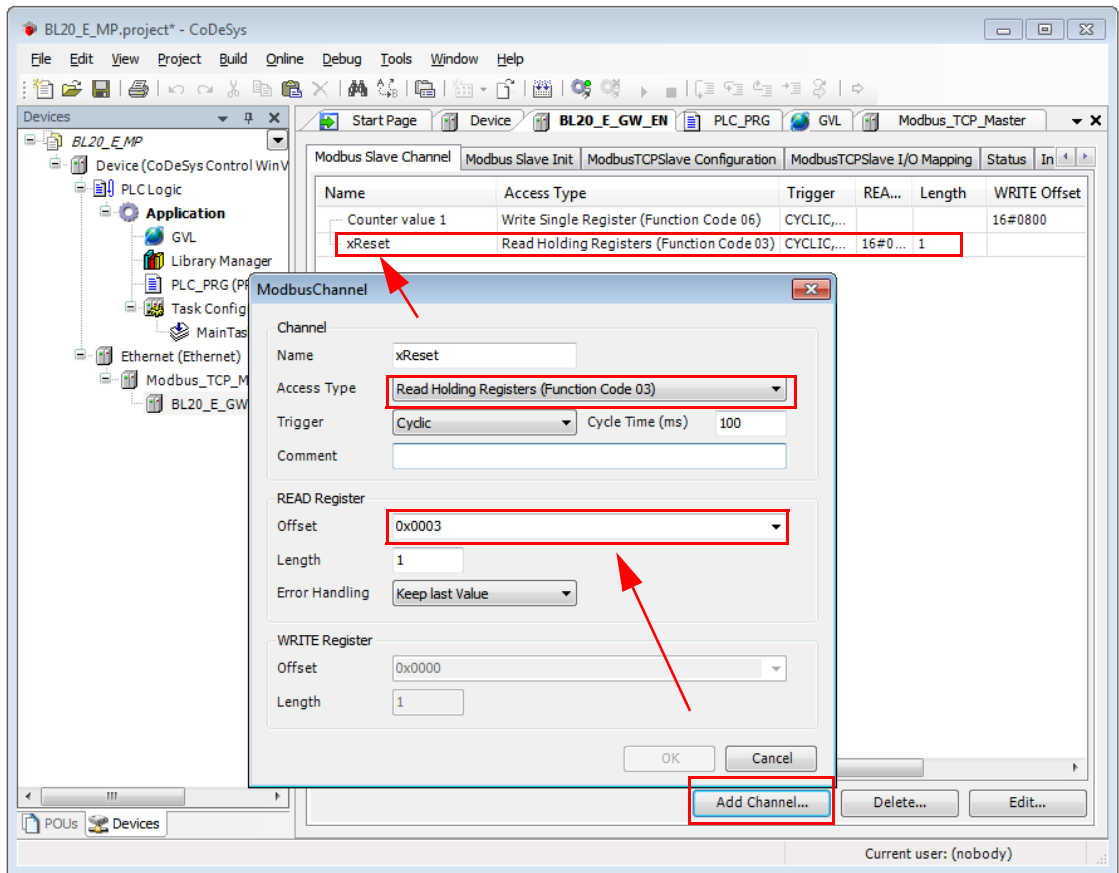

2.2 Mapping:

"xReset" (global variable) to %IX0.0 in %IW0

- "xReset" is mapped to the first bit in %IW0 of BL20-2DI-24VDC-P . This is done in the "ModbusTCP Slave I/O Mapping".
- Double click the field "variable" in the respective line. Use the "..."-button to open the dialog box "Input Assistant".
- Select the variable to be mapped. "xReset" can be found in the global variables as it has been defined there, see [CoDeSys: Global variables](#).

Application example: BL20-E-GW-EN for Modbus TCP (CoDeSys Win V3)

- Confirm with "OK". A "1" at bit %IX0.0 will now reset the counter to zero.

Figure 7-22:
Mapping of
"xReset" to bit
%IX0.0

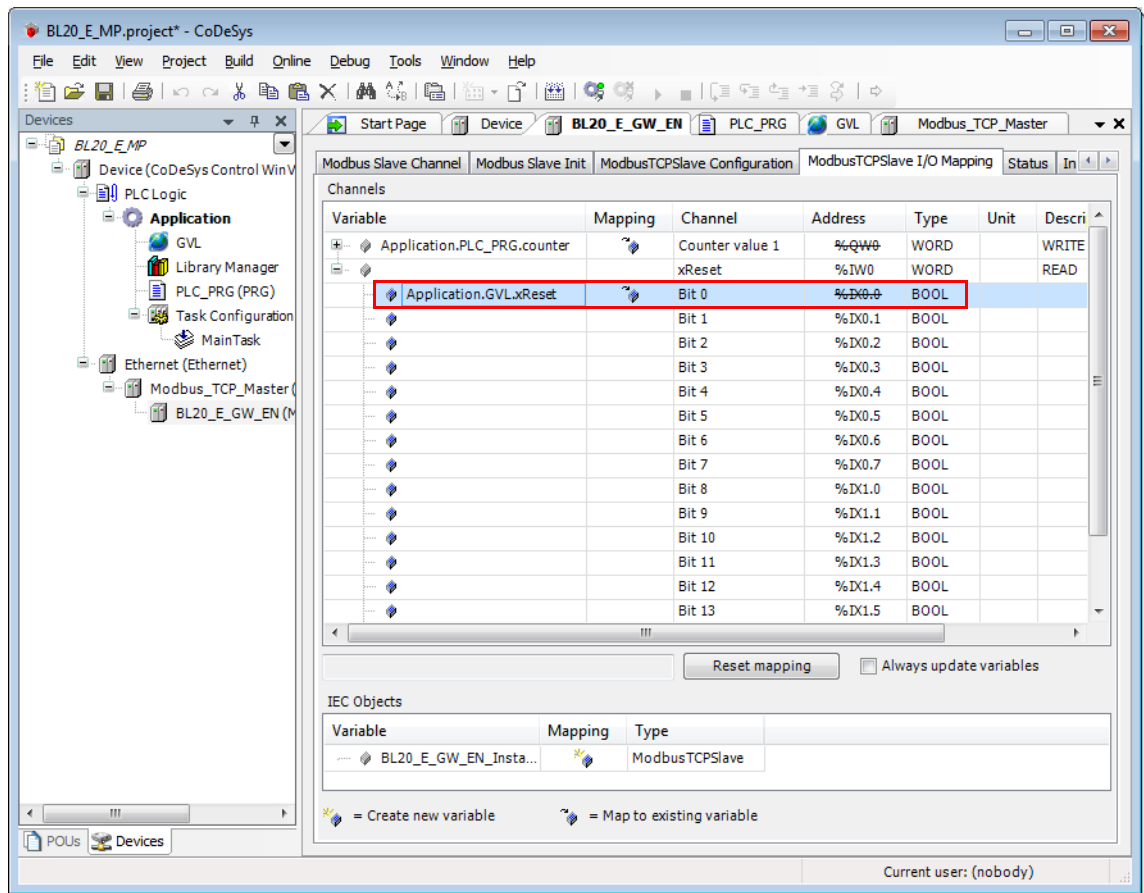

- 3 Read:
 - Reading the station's Status Word
 - Access Type:
Read Holding Registers (function code **03**)
 - Read Register, Offset:
0x0004 (see below)
 - The station's Status Word is read from register 0x0004 and displayed in &IW1 in the ModbusTCP Slave I/O Mapping.

Figure 7-23:
Status Word
mapping acc. to
Modbus-report

2.2. I/O map for input data

Register	Bit position																	
	Hex	Dec	15	14	13	12	11	10	9	8	7	6	5	4	3	2	1	0
0x0000	0000	03.15	03.14	03.13	03.12	03.11	03.10	03.09	03.08	03.07	03.06	03.05	03.04	03.03	03.02	03.01	03.00	
0x0001	0001	04.15	04.14	04.13	04.12	04.11	04.10	04.09	04.08	04.07	04.06	04.05	04.04	04.03	04.02	04.01	04.00	
0x0002	0002	04.31	04.30	04.29	04.28	04.27	04.26	04.25	04.24	04.23	04.22	04.21	04.20	04.19	04.18	04.17	04.16	
0x0003	0003											02.03	02.02	02.01	02.00	01.01	01.00	
0x0004	0004	GW.15	GW.14	GW.13	GW.12	GW.11	GW.10	GW.09	GW.08	GW.07	GW.06	GW.05	GW.04	GW.03	GW.02	GW.01	GW.00	
0x0005	0005											M05	M04	M03	M02	M01	M00	

Description: 1 Column=Register address, n. Column=Modul number.bitposition
 *) GW: gateway status/diagnostics bits
 **) M: module diagnostics (1 bit for each module)

Process input data: 6 Words

Figure 7-24:
Setting the
Modbus channel
for reading
the status word

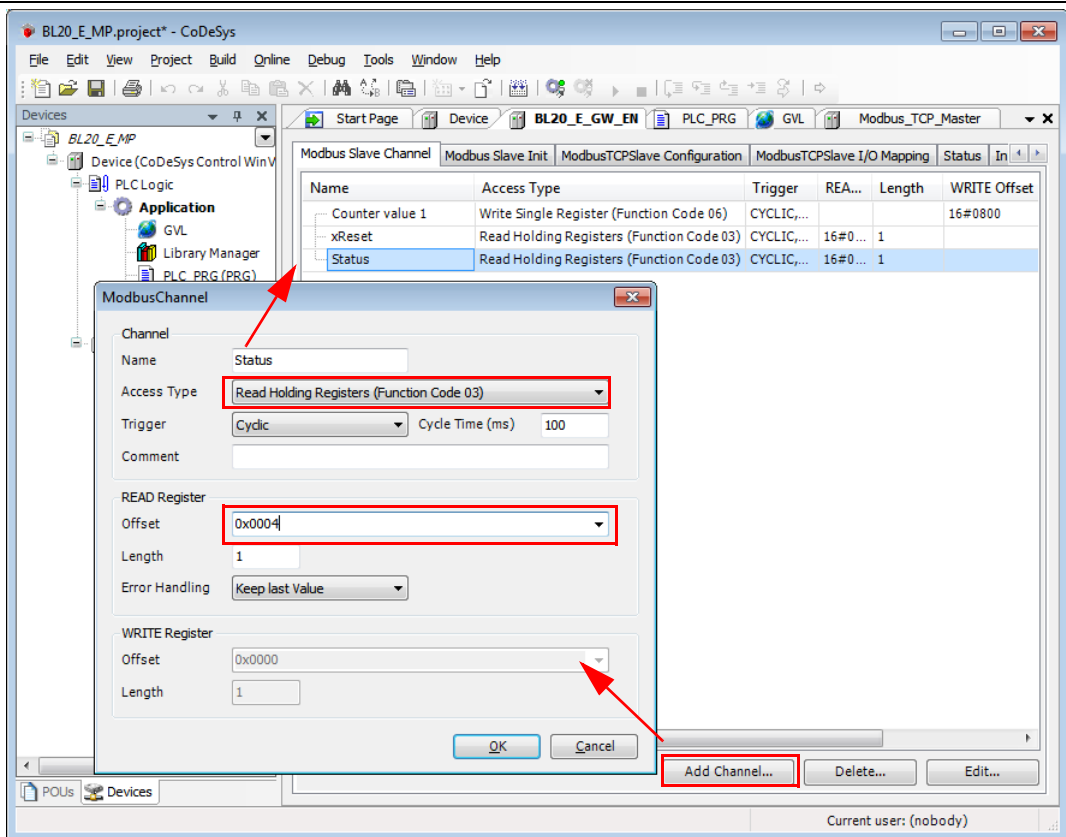

Application example: BL20-E-GW-EN for Modbus TCP (CoDeSys Win V3)

Figure 7-25:
Status Word in
the process
image

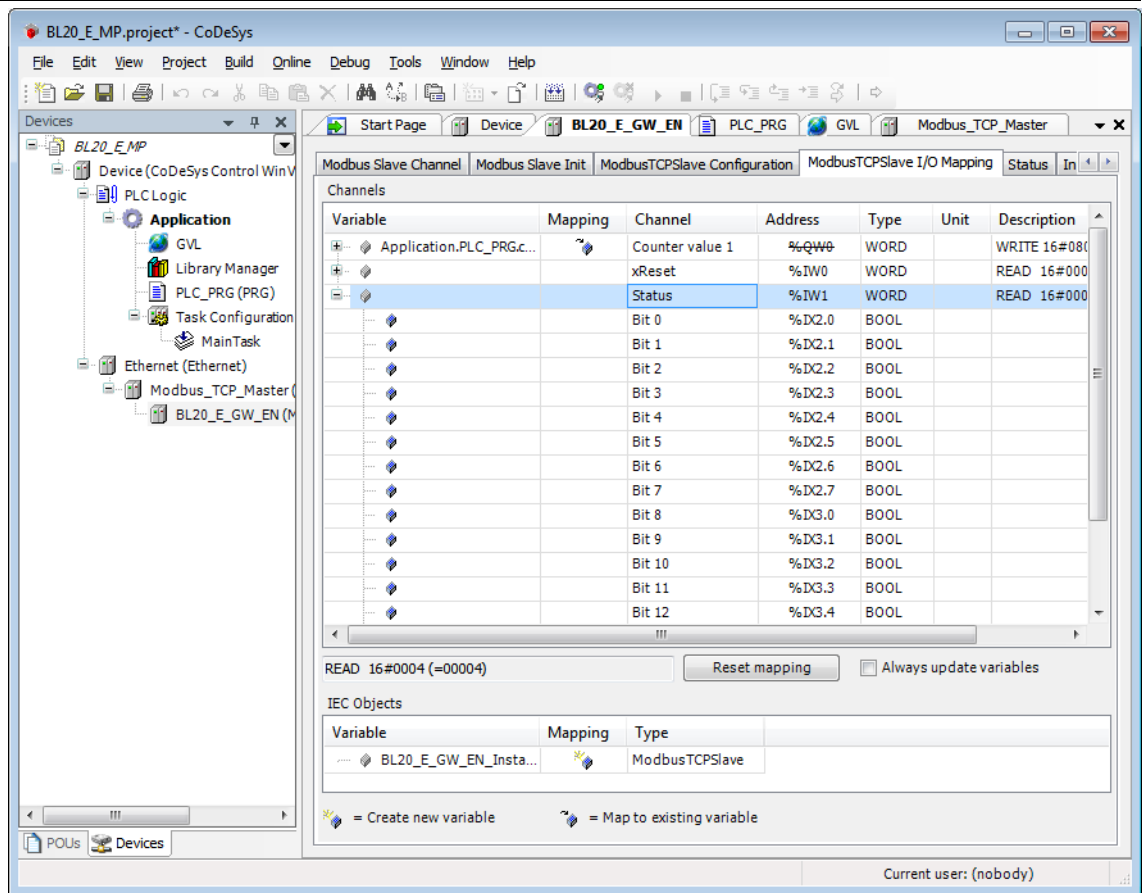

- 4 Write: **Parameters** of the station
 →
 Disable channel diagnosis at channel 1 at slot 3 of the station BL20-1AI-U(-10/0...+10VDC)

Writing parameters is normally done once during the program start and is thus not set as a "normal" Modbus channel under "ModbusSlave Channel", but as an Initialization channel under "**Modbus Slave Init**" (see Figure 7-27: Setting the initialization channel for the parameterization).

- Access Type:
Write Single Register (function code **06**)
- Write Register, Offset:
0xB040 (see below)

The parameters of the station can be found in register 0xB040 to 0xB060.

Parameterization of the station

The example parameterization will be the disabling of the channel diagnosis at channel 1, slot 3 of the station (Register 0xB040, Bit 2).

The parameter register is build up as follows:

Figure 7-26: Assignment of parameter registers

2.4. Map for parameter data

Station report

Register	Bit pos.	Length	Slot	Module	Parameter	Value range
B040	0	1	3	BL20-1AI-U(-10/0...+10VDC)	voltage mode	0: 0..10V 1: -10..+10V
B040	1	1	3	BL20-1AI-U(-10/0...+10VDC)	value representation	0: Integer (15Bit + sign) 1: 12Bit (left-justified)
B040	2	1	3	BL20-1AI-U(-10/0...+10VDC)	diagnostics	0: release 1: block
B040	3	1	3	BL20-1AI-U(-10/0...+10VDC)	channel	0: activate 1: deactivate
B060	0	1	4	BL20-2AI-THERMO-PI	mains suppression	0: 50Hz 1: 60Hz
B060	1	1	4	BL20-2AI-THERMO-PI	value representation	0: Integer (15Bit + sign) 1: 12Bit (left-justified)
B060	2	1	4	BL20-2AI-THERMO-PI	diagnostic	0: release 1: block
B060	3	1	4	BL20-2AI-THERMO-PI	channel	0: activate 1: deactivate

A $2^2 = 4$ will be written to register **0xB040**, which results from the station's the parameter byte assignment.

Figure 7-27: Setting the initialization channel for the parameterization

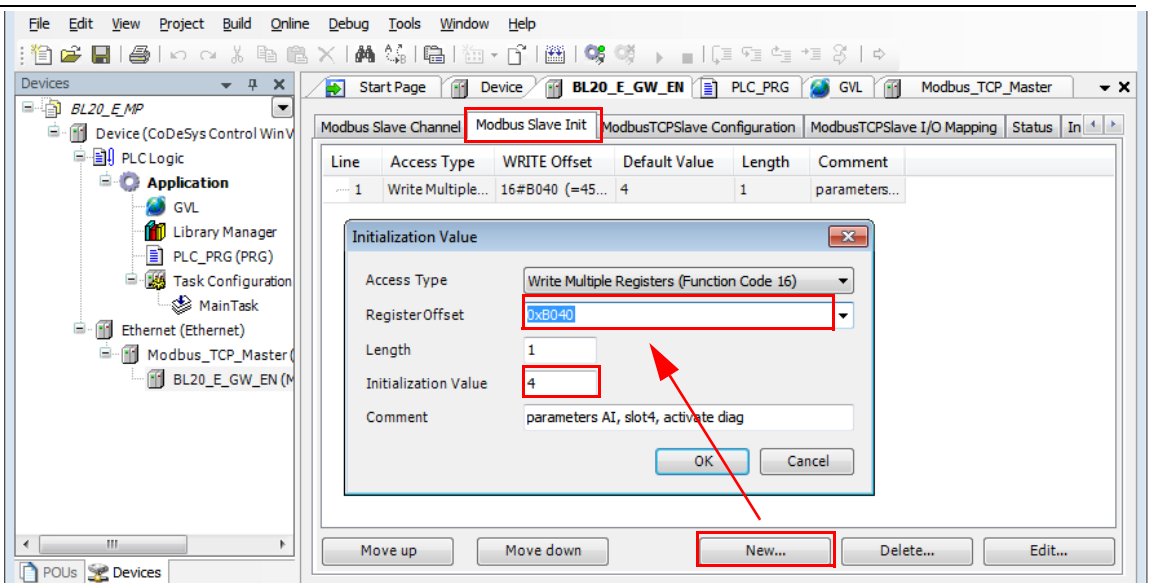

7.3.10 Building, login and start

- 1 The WIN V3-PLC has to be running. This is done in the Windows-task bar:

Figure 7-28:
Starting the WIN
V3-PLC

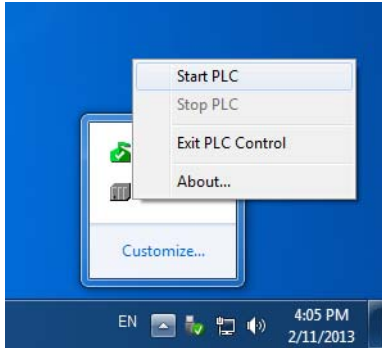

- 2 Building the program:

Figure 7-29:
Building the
program

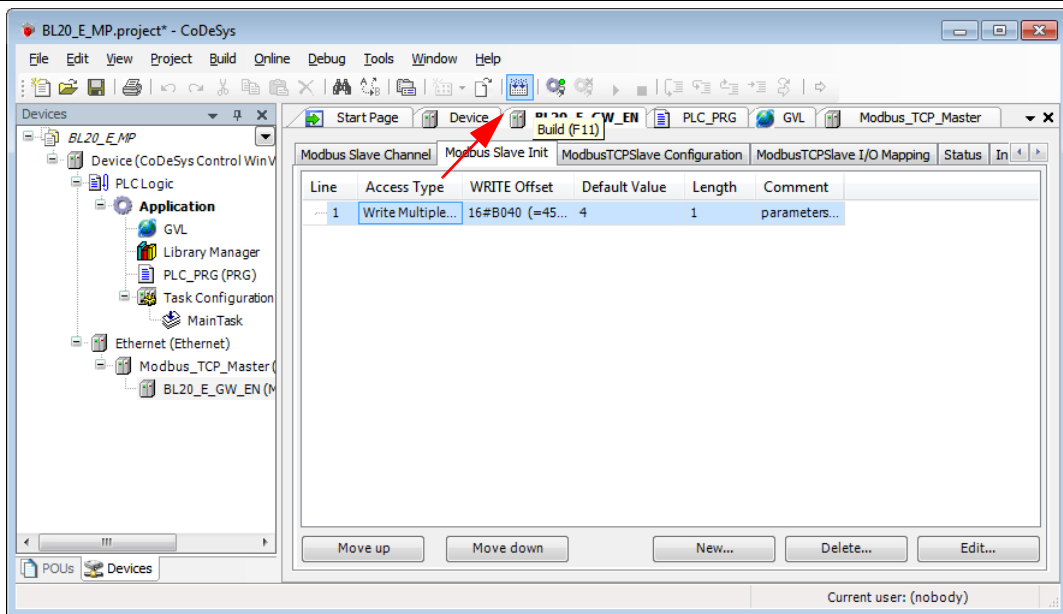

3 Login:

Figure 7-30:
Login

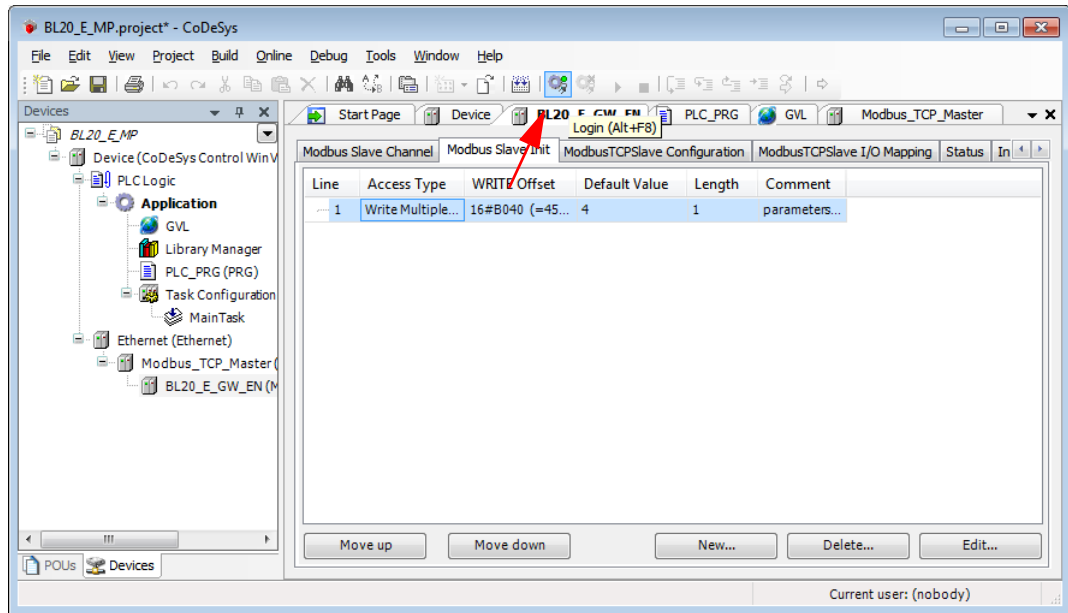

4 Start the program:

Figure 7-31:
Starting the program

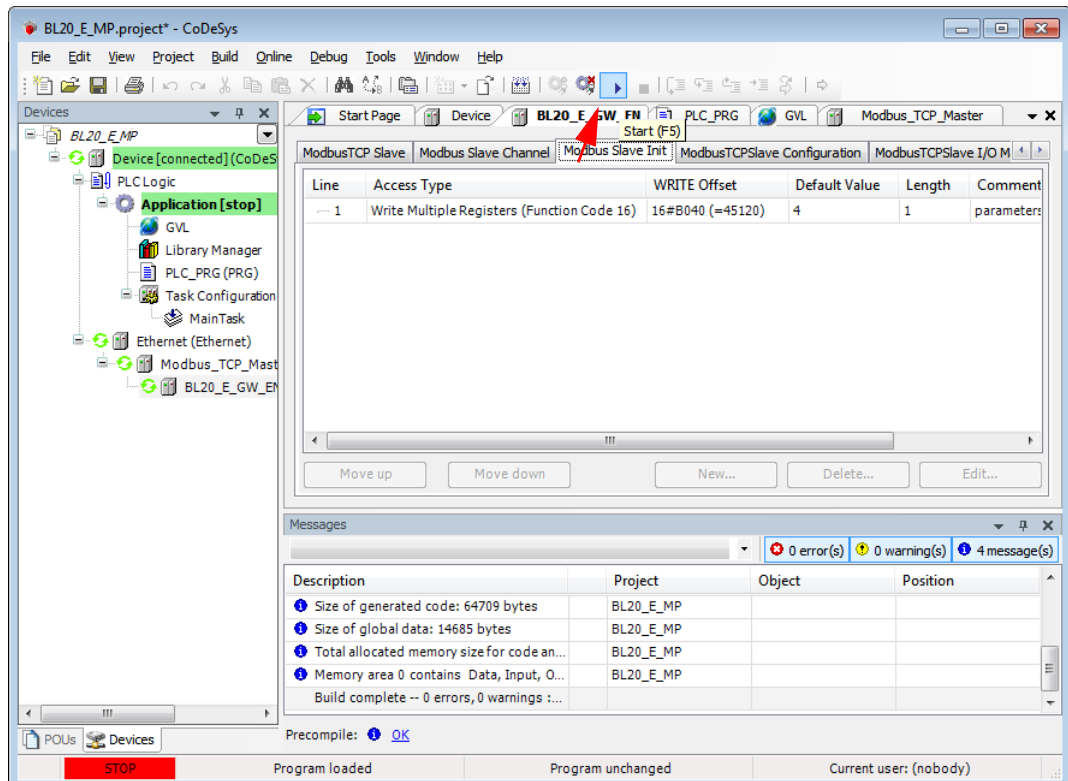

7.3.11 Reading out the process data

The station's process data are shown in the register tab "ModbusTCP Slave I/O Mapping".



Note

In order assure a regular updating of the process data, activate the function "Always update variables".

Figure 7-32:
Modbus TCP
Slave I/O image
with process
data

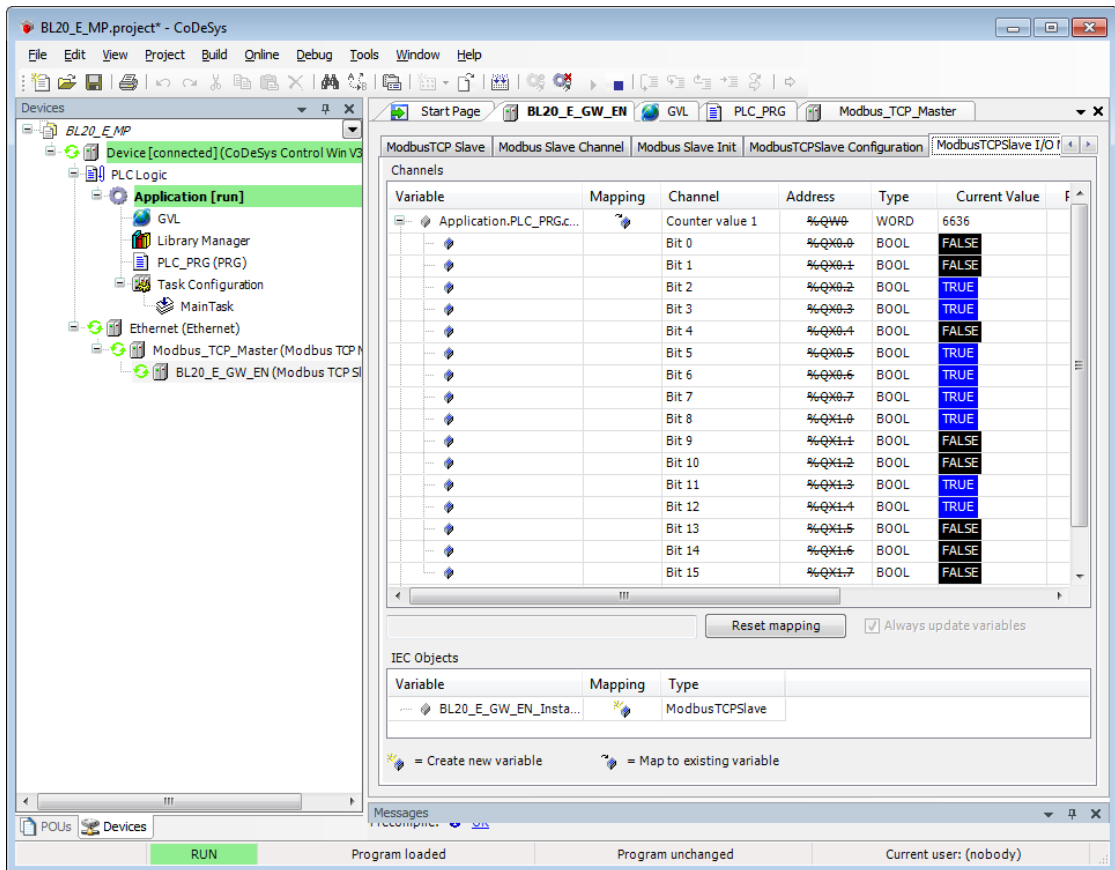

7.3.12 Diagnosis evaluation

Evaluation of the Status word of the BL20-Station (%IW1)

Register 0x0004 contains the Status-word of the Station (see [Modbus data mapping \(page 7-16\)](#)).

According to the definition of the Modbus communication channel (see [Setting the Modbus-channels \(examples\) and data mapping \(page 7-18\)](#)), it is read from **%IW1** of the station image.

Figure 7-33: Status Word of the station

1.2. I/O Belegung der Eingangsdaten

Register		Bitposition															
Hex	Dec	15	14	13	12	11	10	9	8	7	6	5	4	3	2	1	0
0x0000	0000	03.15	03.14	03.13	03.12	03.11	03.10	03.09	03.08	03.07	03.06	03.05	03.04	03.03	03.02	03.01	03.00
0x0001	0001	04.15	04.14	04.13	04.12	04.11	04.10	04.09	04.08	04.07	04.06	04.05	04.04	04.03	04.02	04.01	04.00
0x0002	0002	04.31	04.30	04.29	04.28	04.27	04.26	04.25	04.24	04.23	04.22	04.21	04.20	04.19	04.18	04.17	04.16
0x0003	0003	-	-	-	-	-	-	-	-	-	-	02.03	02.02	02.01	02.00	01.01	01.00
0x0004	0004	GW.15	GW.14	GW.13	GW.12	GW.11	GW.10	GW.09	GW.08	GW.07	GW.06	GW.05	GW.04	GW.03	GW.02	GW.01	GW.00
0x0005	0005	-	-	-	-	-	-	-	-	-	-	M5	M4	M3	M2	M1	M0

Beschreibung: 1. Spalte=Register Adresse, n. Spalte=Modulnummer.Bitposition
 *) GW: Gateway Status-/Diagnosebits
 **) M: Moduldiagnose (1 Bit für jedes Modul)

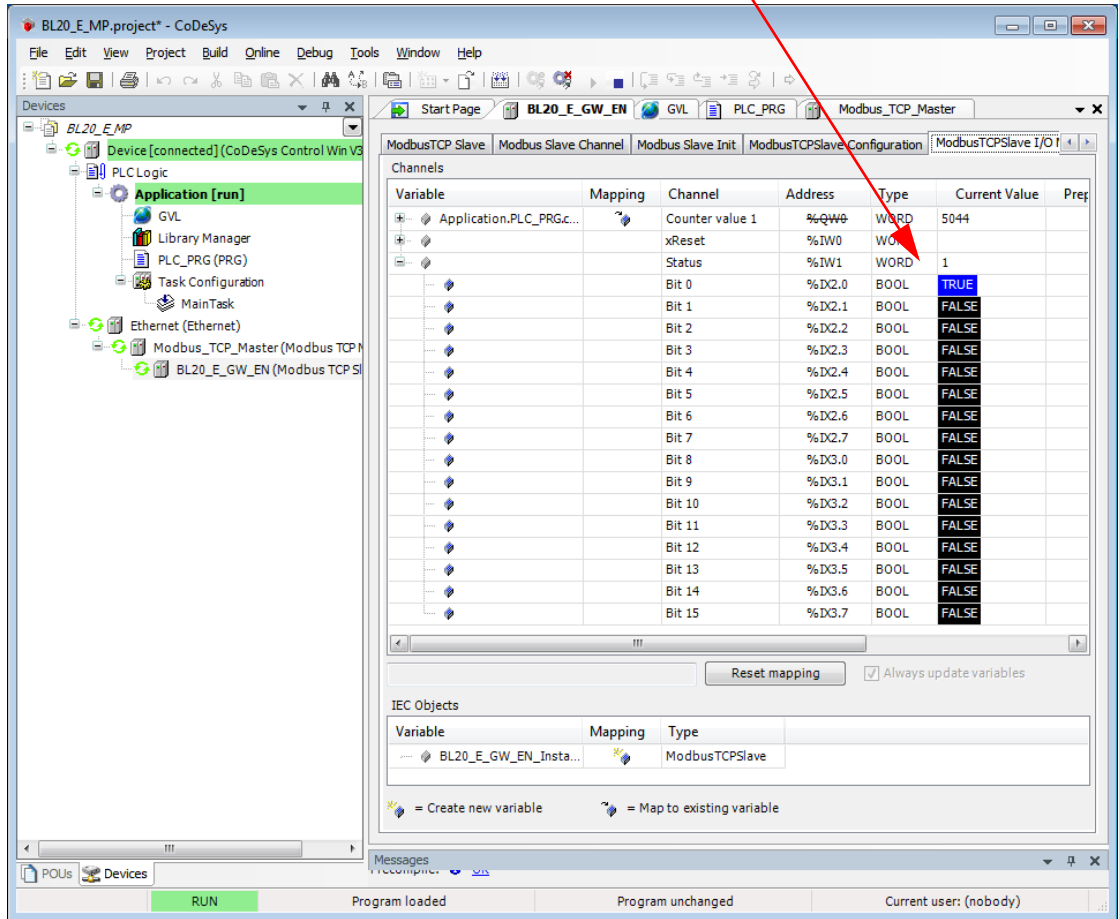

Application example: BL20-E-GW-EN for Modbus TCP (CoDeSys Win V3)

The message has to be interpreted as follows:

Status-register

→ %IW 1, bit 0 = 1

→ status message: „DiagWarn“ = active diagnosis

at least one module at the gateway sends a diagnostic message (see also [Register 0x100C: Gateway status \(page 6-16\)](#)).

Register	Byte	Bit 7	Bit 6	Bit 5	Bit 4	Bit 3	Bit 2	Bit 1	Bit 0
0x0004	0	U _L low	-	-	-	I/O Cfg Warn.	-	-	Diag Warn
	1	-	FCE	-	MB Wdg	I/O CFG	I/O COM	U _{sys} low	U _{sys} high

Evaluation of the group diagnosis

In order to identify the modules, which send diagnostic information, the group diagnosis register is read out. The group diagnosis register always follows the Status word of the gateway in the register mapping. Its position thus depends on the station configuration.

In this example, the group diagnosis register is register 0x0005. It contains on bit per module in the BL20-station, which displays whether the module sends diagnostic information or not.

The order of the bits in the registers corresponds to the order of the I/O-modules within the BL20-station.

Figure 7-34:
Group diagnosis
register

2. Modbus report

2.1. Station description

Station address: 192.168.1.112

Adr./Slot	Name	TAG	Data Size In	Data Size Out
0*	BL20-E-GW-EN (>= VN 03-00)	192.168.1.112/BL20-E-GW-EN (>= VN 03-00)	16 bit	0 bit
1	BL20-2DI-24VDC-P	01/BL20-2DI-24VDC-P	2 bit	0 bit
2	BL20-4DI-24VDC-P	02/BL20-4DI-24VDC-P	4 bit	0 bit
3	BL20-1AI-U(-10/0...+10VDC)	03/BL20-1AI-U(-10/0...+10VDC)	16 bit	0 bit
4	BL20-2AI-THERMO-PI	04/BL20-2AI-THERMO-PI	32 bit	0 bit
5	BL20-2DO-24VDC-0.5A-P	05/BL20-2DO-24VDC-0.5A-P	0 bit	2 bit
6	BL20-E-8DO-24VDC-0.5A-P	06/BL20-E-8DO-24VDC-0.5A-P	0 bit	8 bit
Local I/O data incl. status/control			4 Words	1 Word
Summarized diagnostics			1 Word	0 Words
Total size for in/out data rounded on full words			6 Words	1 Word

*For detailed information about status/control word see online help.

2.2. I/O map for input data

Register	Bit position																	
	Hex	Dec	15	14	13	12	11	10	9	8	7	6	5	4	3	2	1	0
0x0000	0000	03.15	03.14	03.13	03.12	03.11	03.10	03.09	03.08	03.07	03.06	03.05	03.04	03.03	03.02	03.01	03.00	
0x0001	0001	04.15	04.14	04.13	04.12	04.11	04.10	04.09	04.08	04.07	04.06	04.05	04.04	04.03	04.02	04.01	04.00	
0x0002	0002	04.31	04.30	04.29	04.28	04.27	04.26	04.25	04.24	04.23	04.22	04.21	04.20	04.19	04.18	04.17	04.16	
0x0003	0003	-	-	-	-	-	-	-	-	-	-	02.03	02.02	02.01	02.00	01.01	01.00	
**0x0004	0004	GW.15	GW.14	GW.13	GW.12	GW.11	GW.10	GW.09	GW.08	GW.07	GW.06	GW.05	GW.04	GW.03	GW.02	GW.01	GW.00	
**0x0005	0005	-	-	-	-	-	-	-	-	-	-	M05	M04	M03	M02	M01	M00	

Description: 1. Column=Register address, n. Column=Modul number.bitposition

*) GW: gateway status-/diagnostics bits

**) M: module diagnostics (1 bit for each module)

Process input data: 6 Words

According to the examples for setting the modbus channels (see [Setting the Modbus-channels \(examples\) and data mapping \(page 7-18\)](#)), the following channel is add to read out the group diagnosis register.

Read Holding Registers (FC3), register 0x0005, length 1

Figure 7-35:
Channel for
reading out the
group diagnosis

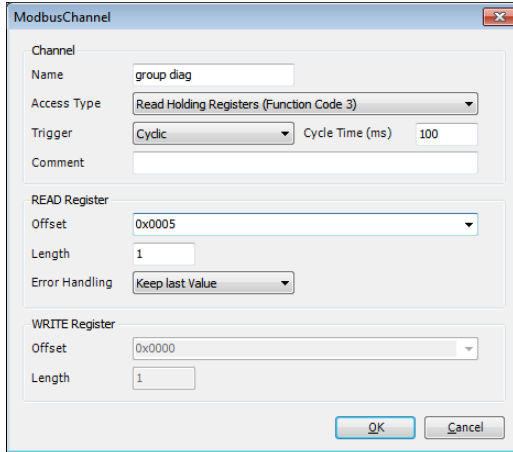

In the example, the group diagnosis is in %IW2:

Figure 7-36:
group diagnosis

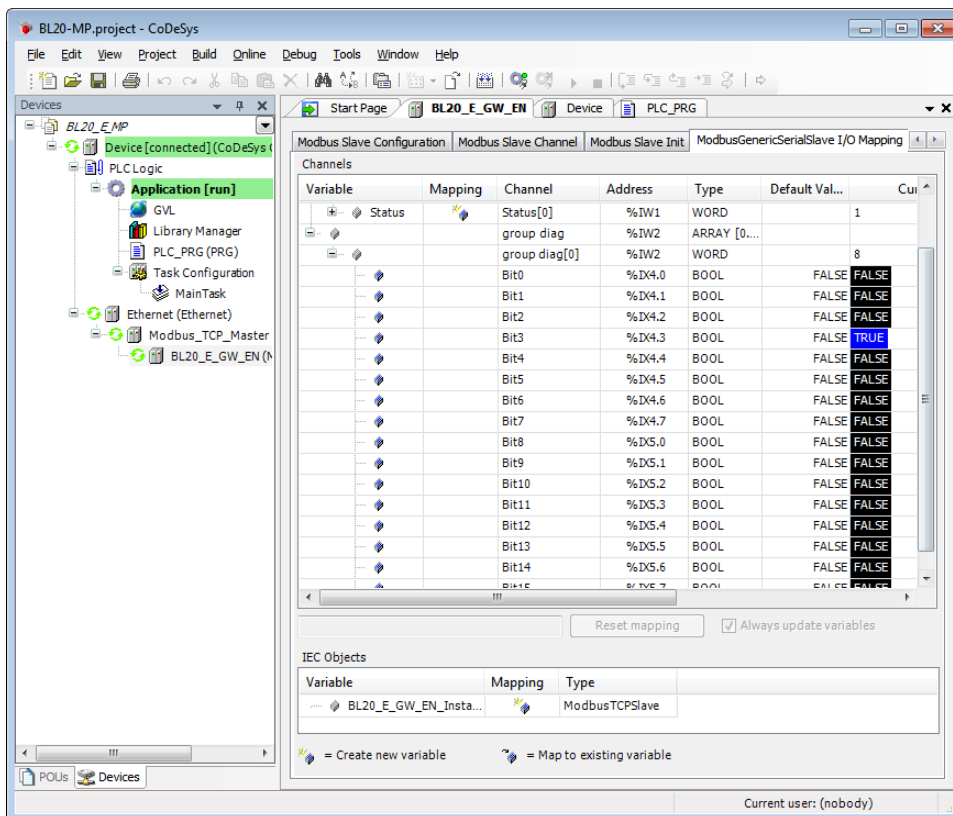

- bit 3 = 1
- slot 4 sends diagnosis information
- BL20-2AI-THERMO-PI (see also [Used hard-/ software \(page 7-2\)](#))

Evaluation of the module diagnosis information

The diagnosis data of module BL20-2AI-THERMO-PI at slot 4 of the example station can be found in registers 0xA060 to 0xA07F (see also Modbus TCP-report (Figure 7-16: Modbus report - Mapping of parameter and diagnostic data (page 7-17)), whereby only register 0xA060 contains diagnosis information.

According to the examples for setting the modbus channels (see Setting the Modbus-channels (examples) and data mapping (page 7-18)), the following channel is add to read out the module diagnosis.

Read Holding Registers (FC3), register 0xA060, length 1:

Figure 7-37: Diagnosis channel

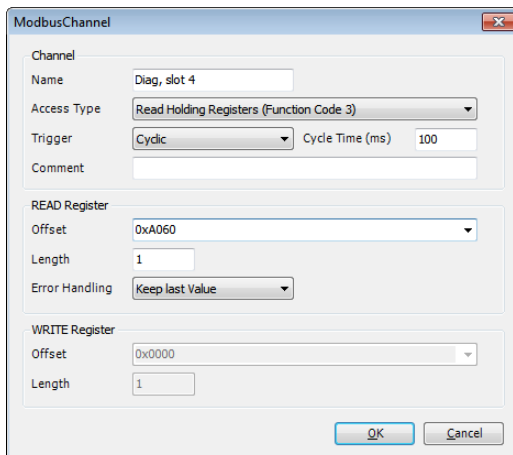

%IW3 in the I/O image of the example station shows the diagnosis information available at slot4:

Figure 7-38: Diagnosis data at slot 4

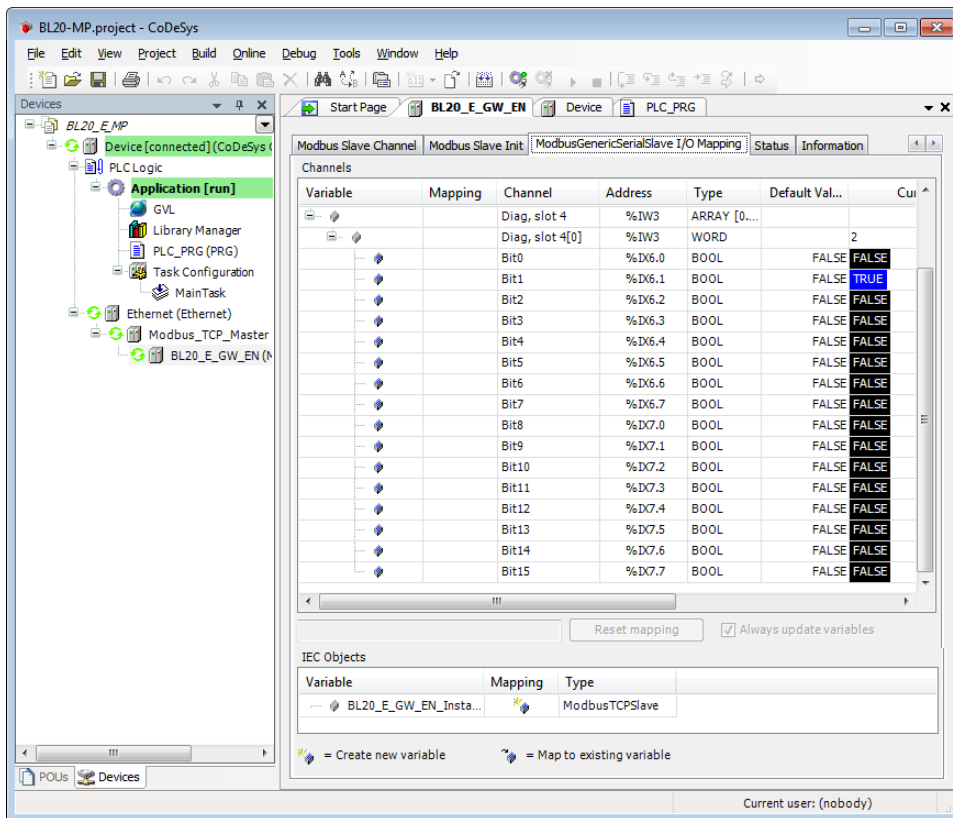

Meaning:

Bit 1: Open circuit at channel 1

(see also [Diagnostic messages of the modules \(page 3-56\)](#))

Figure 7-39:
Mapping of
diagnosis data
according to
Modbus report

1.5. Map for diagnostic data

Register	Bit pos.	Length	Slot	Module	Parameter	Value range
A040	0	1	3	BL20-1AI-U(-10/0...+10VDC)	Overflow/underrun channel x	0 :- 1 : activate
A060	0	1	4	BL20-2AI-THERMO-PI	Measurement value range error channel x	0 :- 1 : activate
A060	1	1	4	BL20-2AI-THERMO-PI	Open circuit channel x	0 :- 1 : activate
A060	2	1	4	BL20-2AI-THERMO-PI	No PT1000 sens or(cold j. comp) channel x	0 :- 1 : activate
A060	8	1	4	BL20-2AI-THERMO-PI	Measurement value range error channel x	0 :- 1 : activate
A060	9	1	4	BL20-2AI-THERMO-PI	Open circuit channel x	0 :- 1 : activate
A060	10	1	4	BL20-2AI-THERMO-PI	No PT1000 sens or(cold j. comp) channel x	0 :- 1 : activate
A080	0	1	5	BL20-2DO-24VDC-0.5A-P	Short circuit channel x	0 :- 1 : activate
A080	1	1	5	BL20-2DO-24VDC-0.5A-P	Short circuit channel x	0 :- 1 : activate

8 Implementation of PROFINET®

8.1	Address assignment	8-2
8.2	GSDML-file	8-3
8.3	Default-values	8-3
8.4	Diagnosis in PROFINET®	8-4
8.4.1	Gateway Error codes	8-4
8.4.2	Channel -specific error codes of the I/O-modules	8-5
	– Meaning of the error codes for the BL20 I/O-modules.....	8-5
8.5	Parameterization	8-10
8.5.1	Gateway parameters	8-10
	– Description of the gateway-parameters.....	8-10
8.5.2	I/O-module-parameters.....	8-13
8.5.3	Parameter "module parameterization"	8-13
8.6	Description of user data for acyclic services	8-14
8.6.1	Description of the acyclic gateway user data	8-14
8.6.2	Description of the acyclic module user data.....	8-15

8.1 Address assignment



Note

In PROFINET®, the connected device is not identified by its IP address, but recognized and addressed by its device name.

The selection of a device name for a special IO device can thus be compared to the setting of the PROFIBUS address for a DP slave.

The device name can be freely chosen.



Note

It is not necessary to address the station's internal module bus.

8.2 GSDML-file

You can download the actual GSDML file for the gateway BL20-E-GW-PN "GSDML-Vxx-Turck-BL20-xxx.xml" from our Homepage www.turck.com.

8.3 Default-values

Default-values:

IP-address	192.168.1.254
subnet mask:	255.255.255.0
Name:	-



Note

When storing the device name or the IP address or when resetting the gateway to the default values, the GW-LED switches to orange.

During this time, the gateway's voltage supply must not be interrupted. In case of a power failure, faulty data will be stored in the gateway.



Note

Resetting the gateway is only possible when the station is not connected to the fieldbus (no AR active). (no AR active).

8.4 Diagnosis in PROFINET®

In PROFINET®, critical events (diagnostic messages) are reported acyclically as alarms.

In addition to information as slot-number, subslot-number, channel type etc., the diagnostic telegrams contain error codes which define the diagnostic event more precisely.

The error codes are interpreted by the PLC-software or respective function block, so that the diagnostic messages are normally displayed as plain text.

You will find an example of a diagnostic telegram in [chapter 9](#), under [Diagnostic telegram with error code \(page 9-19\)](#).

Please read the following sections, for the meaning of the error codes of the gateway and the I/O-modules.

8.4.1 Gateway Error codes

Table 8-1:
gateway
error codes

Value (dec.)	Diagnostics meaning for the gateway
Error codes (1 to 9 according to the standards)	
2	Undervoltage: Undervoltage channel 0: Undervoltage at U_{SYS} Channel 1: Undervoltage at U_L
Error codes (16 to 31 manufacturer specific)	
16	Parametrization error/ configuration error – Station configuration changed → The configuration is currently deviating from the reference list of modules. Process data can still be exchanged with the module bus stations which are at present connected to the module bus. The constellation of the module bus station that is set in the configuration software of the corresponding controller serves as a reference. – Master configuration error → <u>Display:</u> Configuration error/ Parameterizing error at channel 1 → The actual list of modules has been altered in such a manner, that no process data can be exchanged with the module bus stations which are at present connected to the module bus. – Station configuration error → <u>Display:</u> Configuration error/ Parameterizing error at channel 0 → The gateway could not prepare the station's configuration to be read out.
22	behavior at communication loss – Module bus error → Communication with the module bus station on the module bus is not possible.

8.4.2 Channel-specific error codes of the I/O-modules

The channel-specific diagnostic messages of the I/O-modules using error codes are defined as follows:

Table 8-2:
channel-specific
error codes

Value (dec.)	Diagnosis
Error codes (1 to 9 according to the standards)	
1	Short circuit
2	Under voltage
4	overload
5	over temperature
6	wire break
7	overshoot upper limit
8	undershoot lower limit
9	error
Error codes (16 to 28 manufacturer specific)	
16	Parametrization error/ configuration error After a validity check, the parameter data are (partially) rejected by the module. Check the context of parameters. Check the context of parameters.
21	hardware failure The module detected a hardware failure. Exchange the module.
22	behavior at communication loss The module detected a communication problem at its ports, e. g. RS232/485/422, SSI or other interface. Check the connection or the function of the attached devices.
23	Direction error The direction is detected to be wrong. Check the parameterization or the control interface versus use case.
24	User software error The module detected an user application software error. Cold-junction compensation error Re-initialize user the application software of the module.
25	Cold-junction compensation error The module detected a defect or missing cold-junction compensation.
26	Overload sensor supply The module detected a load dump at the sensor supply.
28	Common error The module detected an error. Refer to the I/O-module manuals for a more detailed description of possible errors. Error types can depend on the operation mode and the parameterization.

Meaning of the error codes for the BL20 I/O-modules

The gateway changes the diagnostic messages sent by the BL20 I/O-modules to PROFINET® error codes.

The following table shows, which module message will be changed to which error code.

Table 8-3:
Error codes /
module diag-
nostics

PROFINET® Error code		possible module diagnostics	
No.	Text	I/O module	diagnostic message of the module
1	Short circuit	BL20-2AIH-I	Short circuit
		BL20-4DI-NAMUR	overcurrent
2	Under voltage	BL20-BR-24VDC	channel 0: Undervoltage at U_{SYS} channel 1: Undervoltage at U_L
		BL20-PF-24VDC	channel 1: Undervoltage at U_L
		BL20-E-1SWIRE	voltage U_{SW} , U_{SWERR}
		BL20-2RFID-x	transceiver voltage supply error
3	overvoltage	not sent	
4	overload	BL20-BR-24VDC-D	overcurrent
		BL20-PF-120/230VAC-D	
		BL20-xDO-24VDC-0.5A-x	
		BL20-E-1SWIRE	Overcurrent protective circuit-breaker, PKZE _{RR}
		BL20-2RFID-x	Ident-overcurrent (supply of transceiver is switched-off)
		BL20-4AI-U/I	short circuit (SC)
		BL20-E-8AI-U/I-4AI-PT/NI	
		BL20-2AI-PT/NI-2/3	
		BL20-E-2CNT-2PWM	short-circuit at channel CH2 = P1_DIAG CH4 = P2_DIAG CH3 = D1_DIAG CH5 = D2_DIAG
5	over temperature	not sent	

Table 8-3:
Error codes /
module diag-
nostics

PROFINET® Error code		possible module diagnostics	
No. (dec.)	Text	I/O module	diagnostic message of the module
6	open circuit	BL20-×AI-I(0/4...20MA)	open circuit
		BL20-2AI-PT/NI-2/3	
		BL20-2AI-THERMO-PI	
		BL20-2AIH-I	
		BL20-4AI-U/I	
		BL20-E-8AI-U/I-4AI-PT/NI	
		BL20-E-4AI-TC	
		BL20-2AOH-I	
		BL20-4DI-NAMUR	
7	overshoot upper limit	BL20-×AI-×	Measurement value range error (OoR)
		BL20-2AI-PT/NI-2/3	
		BL20-2AI-THERMO-PI	
		BL20-E-4AI-TC	
		BL20-4AI-U/I	
		BL20-E-8AI-U/I-4AI-PT/NI	
		BL20-2AIH-I	overflow
		BL20-E-4AO-U/I	Measurement value range error (OoR)
		BL20-2AOH-I	Value above upper limit
BL20-1SSI	sensor value overflow		
8	undershoot lower limit	BL20-×AI-×	Measurement value range error (OoR)
		BL20-2AI-PT/NI-2/3	
		BL20-2AI-THERMO-PI	
		BL20-E-4AI-TC	
		BL20-4AI-U/I	
		BL20-E-8AI-U/I-4AI-PT/NI	
		BL20-2AIH-I	undervoltage
		BL20-E-4AO-U/I	Measurement value range error (OoR)
		BL20-2AOH-I	value below lower limit
BL20-1SSI	sensor value underflow		

Table 8-3:
Error codes /
module diagnostics

PROFINET® Error code		possible module diagnostics	
No.	Text	I/O module	diagnostic message of the module
9	error	BL20-E-8AI-U/I-4AI-PT/NI	overflow/ underflow OUF _L
		BL20-E-4AO-U/I	
		BL20-2AOH-I	invalid value
16	parameterization error	BL20-E-1SWIRE	PLC SLAVE, RDYerr
		BL20-1RSxxx	parameterization error
		BL20-1SSI	
		BL20-2RFID-x	invalid parameter
		BL20-E-2CNT-2PWM	parameter error at channel CH0 = CNT1_PAR_ERR CH1 = CNT2_PAR_ERR CH2 = PWM1_PAR_ERR CH4 = PWM2_PAR_ERR
21	hardware failure	BL20-E-8AI-U/I-4AI-PT/NI	Hardware error
		BL20-2AIH-I	
		BL20-E-4AI-TC	
		BL20-E-4AO-U/I	
		BL20-2AOH-I	
		BL20-2RFID-x	transceiver hardware error
		BL20-1RSxxx	Hardware error
22	behavior at communication loss	BL20-2AIH-I	communication error error
		BL20-2AOH-I	
		BL20-E-1SWIRE	Communication SWIRE slave (SD _{ERR})
		BL20-2RFID-x	parameter not supported by transceiver
24	User software error	BL20-2AIH-I	Invalid parameter
		BL20-2AO-H	
		BL20-2RFID-x	software error
25	Cold-junction compensation error	BL20-2AI-THERMO-PI	no Pt1000-sensor found
		BL20-E-4AI-TC	
27	unknown error	BL20-E-2CNT-2PWM	Hardware error

Table 8-3:
Error codes /
module diag-
nostics

PROFINET® Error code		possible module diagnostics	
No.	Text	I/O module	diagnostic message of the module
28	Common error	BL20-2AIH-I	HART® status error
		BL20-E-4AI-TC	Measurement value range error
		BL20-2AOH-I	HART® status error
		BL20-E-1SWIRE	general error message, GEN _{ERR}
		BL20-1SSI	SSI group diagnostics
29	configuration error	BL20-E-1SWIRE	SWIRE MASTER (SW _{ERR}) TYPE ERROR (TYPE _{ERR})

8.5 Parameterization

8.5.1 Gateway parameters

The BL20-gateways for PROFINET® occupie 4 parameter bytes.

Description of the gateway-parameters

Table 8-4:
gateway
parameters

A default
setting

Byte	Bit parameters	Value	Meaning
0	Byte 0		
	bit 0, bit 1 Output behavior if one module is missing		
	00	output 0 A	The gateway switches the outputs of modules to "0". No error information is transmitted. No error information is transmitted.
	01	output substitute value	The gateway switches the outputs of all modules to "0" (with the exception of analog output modules). Error information is transmitted to the analog output modules. Depending on their configuration, these modules set their outputs either to "0" or to a default value, or to maintain the original values. The non-configured analog output modules set their outputs to "0".
	10	hold current value	The gateway maintains the actual output settings of all modules (with the exception of analog output modules). Error information is transmitted to the analog output modules. Depending on their configuration, these modules set their outputs either to "0" or to a default value, or to maintain the original values. The non-configured analog output modules set their outputs to "0".
	11	exchange process data	The gateway carries on exchanging process data with the other module bus stations. No error information is transmitted.
	bit 2, bit 3 Output behavior if one module is wrong		
	00	output 0 A	The gateway switches the outputs of modules to "0". No error information is transmitted. No error information is transmitted.
	01	output substitute value	The gateway switches the outputs of all modules to "0" (with the exception of analog output modules). Error information is transmitted to the analog output modules. Depending on their configuration, these modules set their outputs either to "0" or to a default value, or to maintain the original values. The non-configured analog output modules set their outputs to "0".

Table 8-4:
gateway
parameters

Byte	Bit parameters	Value	Meaning	
0 bit 2, bit 3 Output behavior if one module is wrong				
A default setting		10	hold current value	The gateway maintains the actual output settings of all modules (with the exception of analog output modules). Error information is transmitted to the analog output modules. Depending on their configuration, these modules set their outputs either to "0" or to a default value, or to maintain the original values. The non-configured analog output modules set their outputs to "0".
		11	exchange process data	The gateway carries on exchanging process data with the other module bus stations. No error information is transmitted.
bit 4, bit 5 Output behavior at communication loss				
		00	output 0 A	The gateway switches the outputs of modules to "0". No error information is transmitted. No error information is transmitted.
		01	output substitute value	The gateway switches the outputs of all modules to "0" (with the exception of analog output modules). Error information is transmitted to the analog output modules. Depending on their configuration, these modules set their outputs either to "0" or to a default value, or to maintain the original values. The non-configured analog output modules set their outputs to "0".
		11	hold current value	The gateway maintains the actual output settings of all modules (with the exception of analog output modules). Error information is transmitted to the analog output modules. Depending on their configuration, these modules set their outputs either to "0" or to a default value, or to maintain the original values. The non-configured analog output modules set their outputs to "0".
1	Bit 0: reserved			
	Bit 1: Disable all diagnosis			
		0	inactive A	Diagnostic messages and alarms are generated.
		1	active	Diagnostic messages and alarms are not generated.

Table 8-4:
gateway
parameters

A default
setting

Byte	Bit parameters	Value	Meaning	
1	Bit 2: Disable output power diagnosis			
	0	inactive A	A monitoring of the field supply V_O (from the gateway and the Power-Feeding modules) is activated. If this parameter is set but the parameter "Diagnostics from modules" (see bit 1) deactivated, then only the voltage supply at the gateway is monitored. The voltage supply with V_O at is not monitored at the power feeding modules.	
	1	active	An possible over- or undervoltage for V_O is not monitored.	
	Bit 3: reserved			
	Bit 4: I/O-ASSISTANT Force Mode disable			
	0	inactive A	-	
	1	active	The I/O-ASSISTANT is not able to access the gateway via Force Mode.	
	Bit 5: reserved			
	Bit 6: Startup also if configuration does not match			
	0	inactive A	Changes in the station configuration are stored in the gateway following a power-on reset.	
	1	active	If the static configuration is deactivated, a dynamic configuration take-over is realized directly following station configuration changes (important for acyclic parameterization).	
	Bit 7: reserved			
	2	Bit 0: EtherNet/IP deactivated		
		0	inactive A	Explicit deactivating of the other Ethernet-protocols as well as of the web server.
1		active		
Bit 1: Modbus TCP deactivated				
0		inactive A		
1		active		
Bit 2 to Bit 7: reserved				
3	Bit 0 to Bit 6: reserved			
	Bit 7: Web server deactivated			
	0	inactive A	Explicit deactivating of the web server	
	1	active		

8.5.2 I/O-module-parameters

The description of the single I/O-module-parameters is protocol-independent and can thus be found in [chapter 3.9, Parameters of the I/O-modules \(page 3-33\)](#).

8.5.3 Parameter "module parameterization"

Each parameterizable module, gets the additional parameter "module parameterization" via the GSDML-file of the gateway.

**Note**

This parameter is not part of the module parameters, but is only important for the communication between gateway and the modules.

This parameter extension is always necessary, even if the module is parameterized via a IO-supervisor.

■ "module parameterization" activated

The module receives its parameter settings from the controller, IO-supervisor, I/O-ASSISTANT or similar.

In this case, parameter changes which were done in the meantime for example by a configuration tool or similar will be overwritten with the valid parameter data set.

■ "module parameterization" deactivated

Changes in the parameter settings are ignored for the respective module. The stored parameter data will be used.

**Note**

If the "module parameterization" is activated and a module is replaced by a new one, the gateway has to be operated with active U_{SYS} , in order to keep the module's parameter-settings for the new module.

U_L has to be switched-off and the station has to be separated from the field bus. Now, the gateway sends the parameters defined for the old module, into the new module.

8.6 Description of user data for acyclic services

The acyclic data exchange is done via Record Data CRs (CR→ Communication Relation).

Via these Record Data CRs the reading and writing of the following services is realized:

- Writing of configuration data
- Reading and writing of device data
- Reading of diagnostic data
- Reading of I/O data
- Reading of Identification Data Objects (I&M functions)
- Reading of differences between the expected and the actually plugged modules

8.6.1 Description of the acyclic gateway user data

Table 8-5:
Gateway Appli-
cation Instance

Index	Name	Data Type	r/w	Comment
1 (0x01)	Gateway parameters	WORD	r/w	Parameter data of the module
2 (0x02)	gateway Designation	STRING	r	Product name of the gateway
3 (0x03)	Gateway revision	STRING	r	Firmware-revision of the gateway
4 (0x04)	Vendor-ID	WORD	r	Ident number for TURCK
5 (0x05)	Gateway-Name	STRING	r	Name assigned to the gateway
6 (0x06)	Gateway type	STRING	r	Device type of the gateway
7 (0x07)	Device-ID	WORD	r	Ident number of the gateway
8 (0x08) to 23 (0x17)	reserved			
24 (0x18)	Gateway diagnosis	WORD	r	Diagnosis data of the gateway
025 (0x19) to 31 (0x1F)	reserved			
32 (0x20)	Module input list	Array of BYTE	r	List of all input channels in the station
33 (0x21)	Module output list	Array of BYTE	r	List of all output channels in the station

Table 8-5: Gateway Application Instance

Index	Name	Data Type	r/w	Comment
34 (0x22)	Module diag. list	Array of BYTE	r	List of all module diagnosis messages
35 (0x23)	Module parameter list	Array of BYTE	r	List of all module parameters
36 (0x24) to 45039 (0xAFF0)	reserved			
45040 (0xAFF0)	I&M0-functions		r	Identification & Maintenance
45041 (0xAFF1)	I&M1-functions	STRING[54]	r/w	not supported
45042 (0xAFF2)	I&M2-functions	STRING[16]	r/w	
45043 (0xAFF3)	I&M3-functions	STRING[54]	r/w	
45044 (0xAFF4)	I&M4-functions	STRING[54]	r/w	
45045 (0xAFF5)	I&M5-functions			
28672 (0x7000)	Gateway parameters	WORD	r/w	activating/ deactivating the Ethernet-protocols (see also Gateway parameters (page 8-10))

8.6.2 Description of the acyclic module user data

Table 8-6: Module user data

Index	Name	Data type	r/w	Comment
1 (0x01)	Module parameter	specific	r/w	Parameter of the module
2 (0x02)	Module type	ENUM UINT8	r	Module type
3 (0x03)	Module version	UINT8	r	Firmware-revision of the module
4 (0x04)	Module ID	DWORD	r	Ident number of the module
5 (0x05) to 18 (0x12)	reserved			

Implementation of PROFINET®

19 (0x13)	Input data	specific	r	Input data of the respective module
20 (0x14) to 22 (0x16)	reserved			
23 (0x17)	Output data	specific	r/w	Output data of the respective module
24 (0x18) to 31 (0x1F)	reserved			
32 (0x20) to 255 (0xFF)	Profile-specific	These indices are reserved for the data of several module profiles (e. g. RFID). The definitions of the profile indices can be found in the respective module descriptions.		

9 Application example: BL20-E-GW-EN with PROFINET® (S7)

9.1	Application example	9-2
9.1.1	General	9-2
9.1.2	Example network	9-2
9.1.3	New project in the Simatic Manager	9-3
9.1.4	Setting the PG/PC-interface	9-3
9.1.5	Installation of the GSDML-files	9-4
9.1.6	Adding PROFINET®-network nodes	9-8
	– Adding a BL20-gateway and configuring the BL20-station	9-9
9.1.7	Configuring the BL20-station	9-11
9.1.8	Scanning the network for PROFINET® nodes	9-12
	– Device name assignment BL20-gateway	9-13
9.1.9	PROFINET neighborhood detection via LLDP	9-14
	– Necessary setting of the PROFINET®-controller	9-14
	– Configuring the neighborhood detection	9-15
9.1.10	Online topology detection	9-17
9.2	Diagnostics with Step 7	9-18
9.2.1	Diagnostic messages in the hardware configuration	9-18
9.2.2	Diagnostic telegram with error code	9-19

9.1 Application example

9.1.1 General

In order to configure the connection of a BL20 multi-protocol gateway for PROFINET® to a Siemens PLC S7, the software package "SIMATIC Manager" version 5.5 from Siemens is used.

9.1.2 Example network

- Siemens PLC S7, CPU 315-2 PN/DP, 6ES7 315-2EH14-0AB0, V3.2
 - device name: pn-io
 - IP address: 192.168.1.112
- FGEN-IOM88-5001
 - device name: turck-fgen-107
 - IP-address: not assigned, yet
- FGEN-XSG16-5001
 - device name: turck-fgen-90
 - IP-address: not assigned, yet
- BL20-E-GW-EN
Gateway for connecting PROFINET® to the BL20 example station (see [Table 9-1: Example station](#)).
 - Device name: not assigned, yet
 - IP-address: not assigned, yet

Table 9-1:
Example station

	Module	Data width	
		Process input	Process output
GW	BL20-E-GW-EN		
1	BL20-2DI-24VDC-P	2 Bit	-
2	BL20-4DI-24VDC-P	4 Bit	-
3	BL20-2AI-U(-10/0...+10VDC)	4 Byte	-
4	BL20-2AI-THERMO-PI	4 Byte	
5	BL20-2DO-24VDC-0.5A-P		2 Bit
6	BL20-E-8DO-24VDC-0.5A-P		8 Bit

9.1.3 New project in the Simatic Manager

- 1 Create a new project in the Simatic Manager using the "File →New"-command
- 2 Add a Simatic station to the project using the "Insert → station..."-command. In this example a "Simatic 300 station" is used.

Figure 9-1:
Selecting a
Simatic station

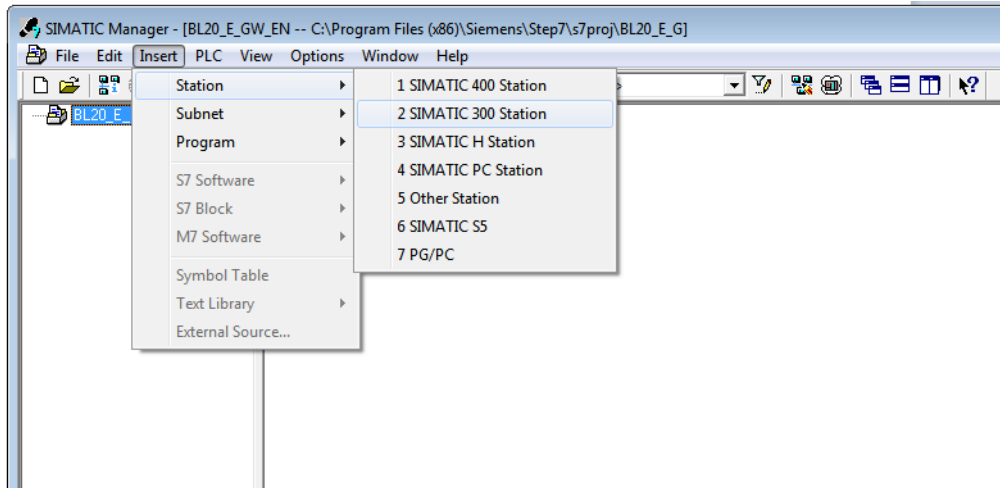

The configuration of the PROFINET®-network is then done in the software's hardware configuration

9.1.4 Setting the PG/PC-interface

In order to be able to build up communication between the PLC and your PG/PC via Ethernet, the respective interface/ network card of the PG/PC has to be activated.

The configuration of the interface is done via the "Set PG/PC Interface" command.

Open this dialog in the Simatic software for example via the "Options → Set PG/PC Interface..." command or directly in the Windows Control Panel for your PG/PC.

Figure 9-2:
Command "Set
PG/PC Inter-
face..."

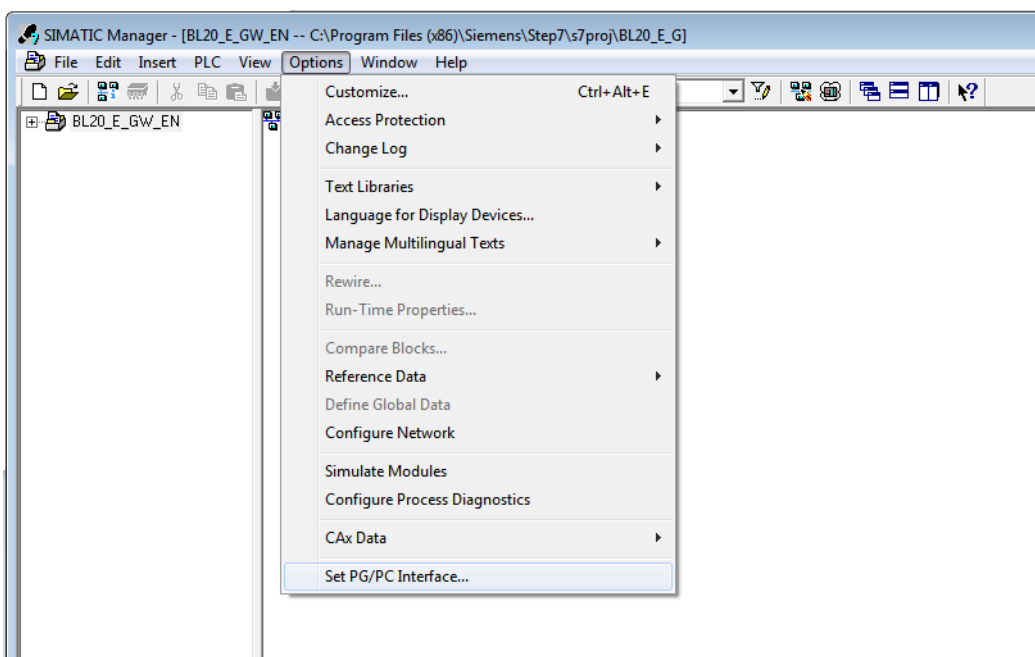

9.1.5 Installation of the GSDML-files

- 1 In the hardware configuration "HW config", open the "Options→ Install GSD file" command in order to install new GSD-files.

Figure 9-3:
GSD files
install

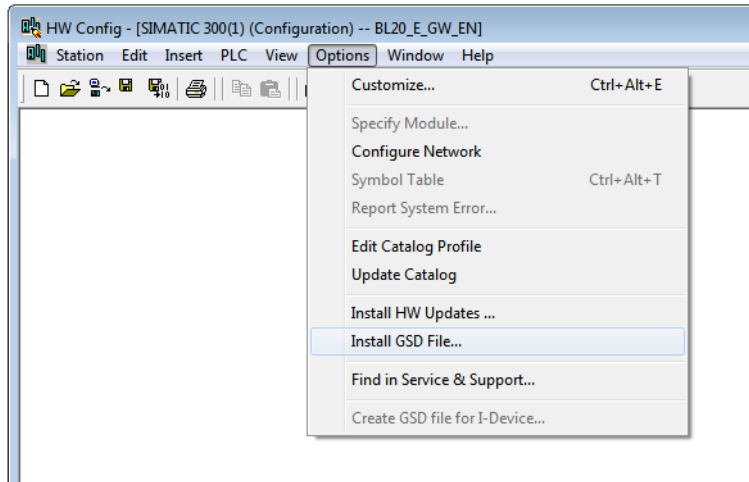

- 2 Define the directory for the TURCK GSDML-files by browsing the directories and add the BL20 PROFINET® gateway to the hardware catalog.

Figure 9-4:
Install GSD files

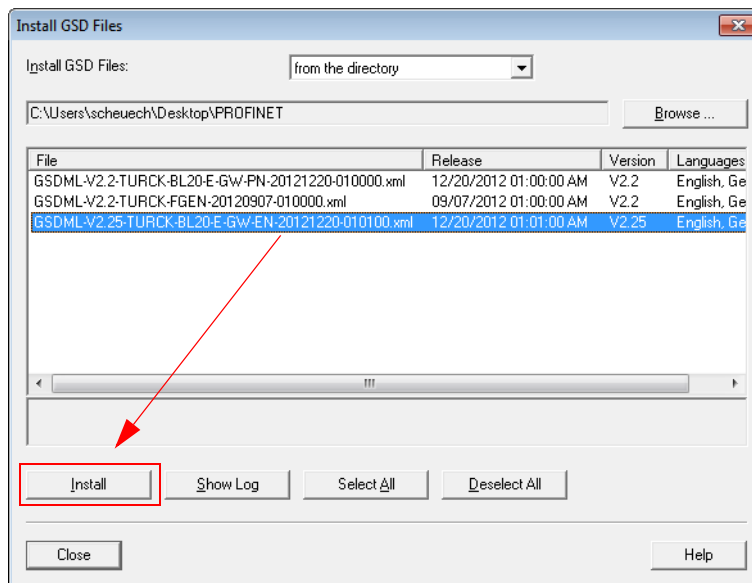

The new gateway can now be found under "PROFINET IO → Additional Field Devices → I/O → TURCK".

Figure 9-5:
BL20 gateway in
the hardware
catalog

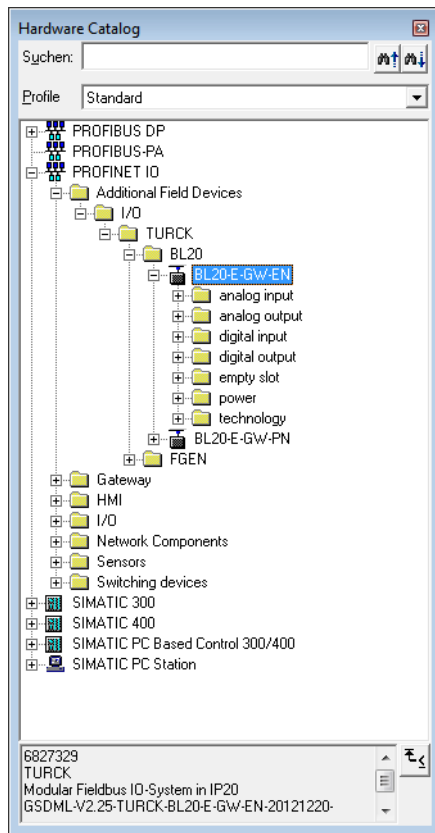

- 3 Chose the profile rack "RACK-300" for the Siemens CPU from the catalog and add it to the network window.

Application example: BL20-E-GW-EN with PROFINET® (S7)

- After this, select the Siemens CPU from the hardware catalog. In this example a CPU 315-2 PN/DP, version 6ES7 315-2EH14-0AB0 (V 3.2), is used.

Figure 9-6:
Selecting the
CPU

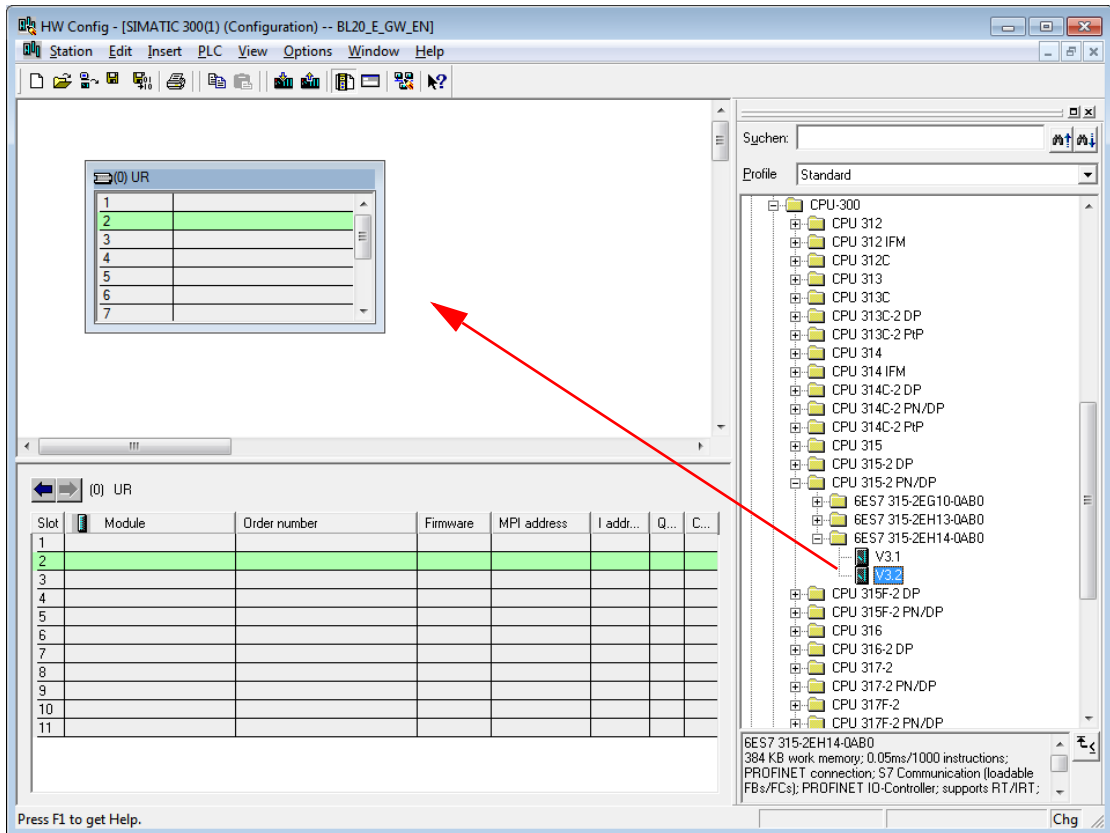

- In the dialog "Properties Ethernet Interface", define the IP address and the subnet mask for the S7 CPU and add the subnet using the "New..." button.

Figure 9-7:
Properties
Ethernet inter-
face

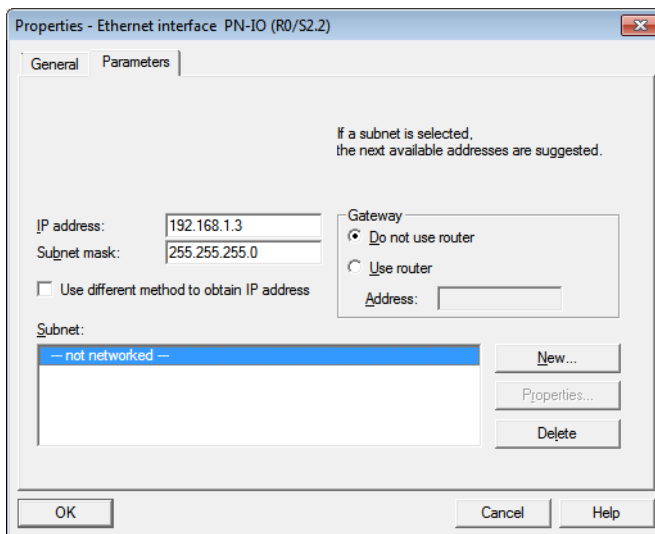
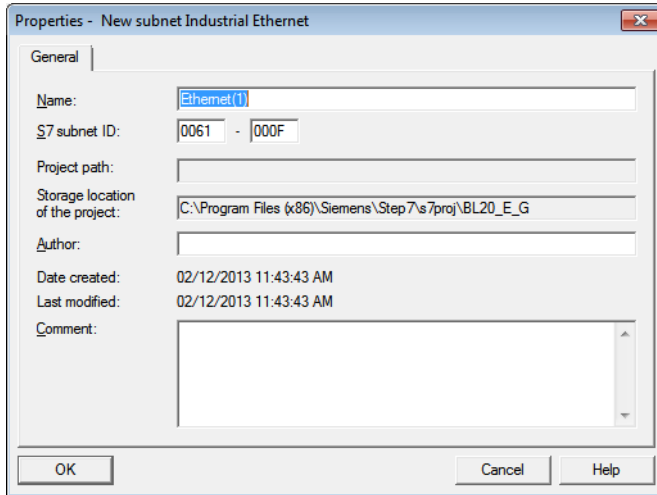

Figure 9-8:
Add new
Ethernet subnet



9.1.6 Adding PROFINET®-network nodes

The nodes of the example network (see [page 9-2](#)) are added to the PROFINET® as follows:

- FGEN
 - FGEN-IOM88-5001, device name: turck-fgen-107
 - FGEN-XSG16-5001, device name: turck-fgen-90

Figure 9-9:
Add network
node

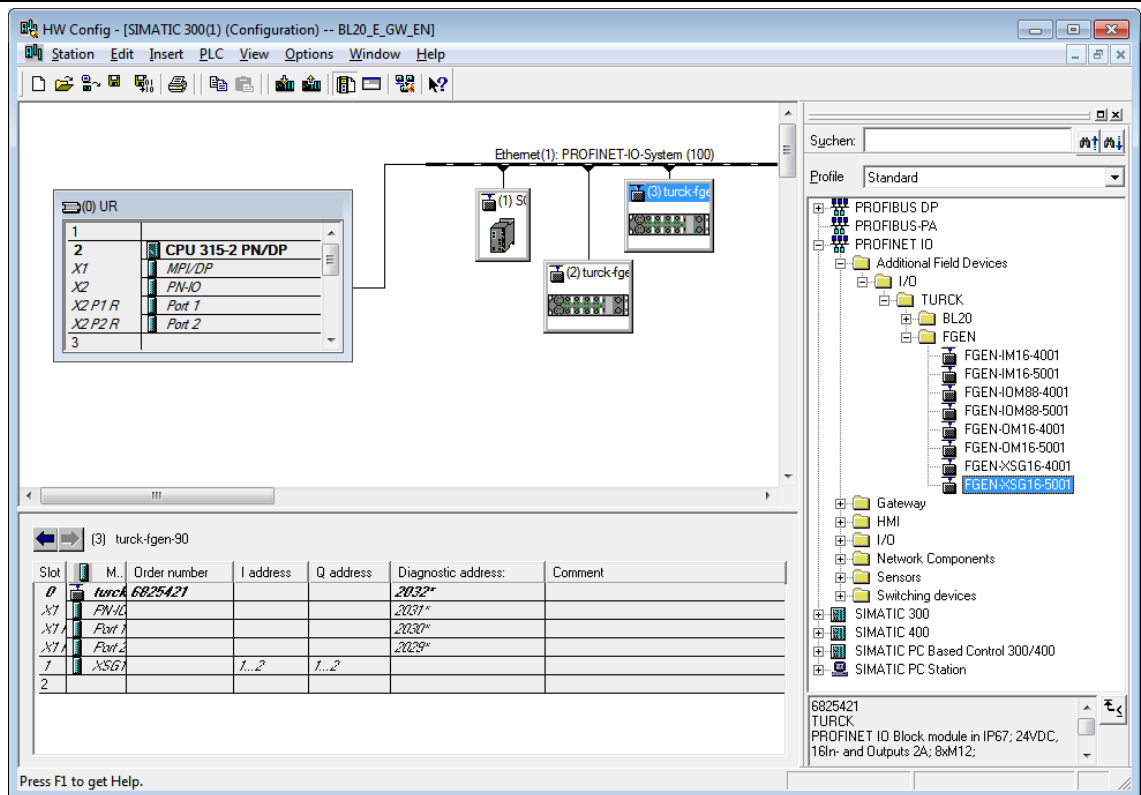

Adding a BL20-gateway and configuring the BL20-station

Now, the BL20-gateway is selected from the Hardware Catalog and added to the configuration

- BL20-E-GW-EN
 - Device name: not assigned, yet
 - IP-address: not assigned, yet
- 1 Select the gateway under "PROFINET IO → Additional Field Devices → I/O → TURCK → BL20" and add it to the Ethernet-network.

Figure 9-10:
Select BL20
gateway

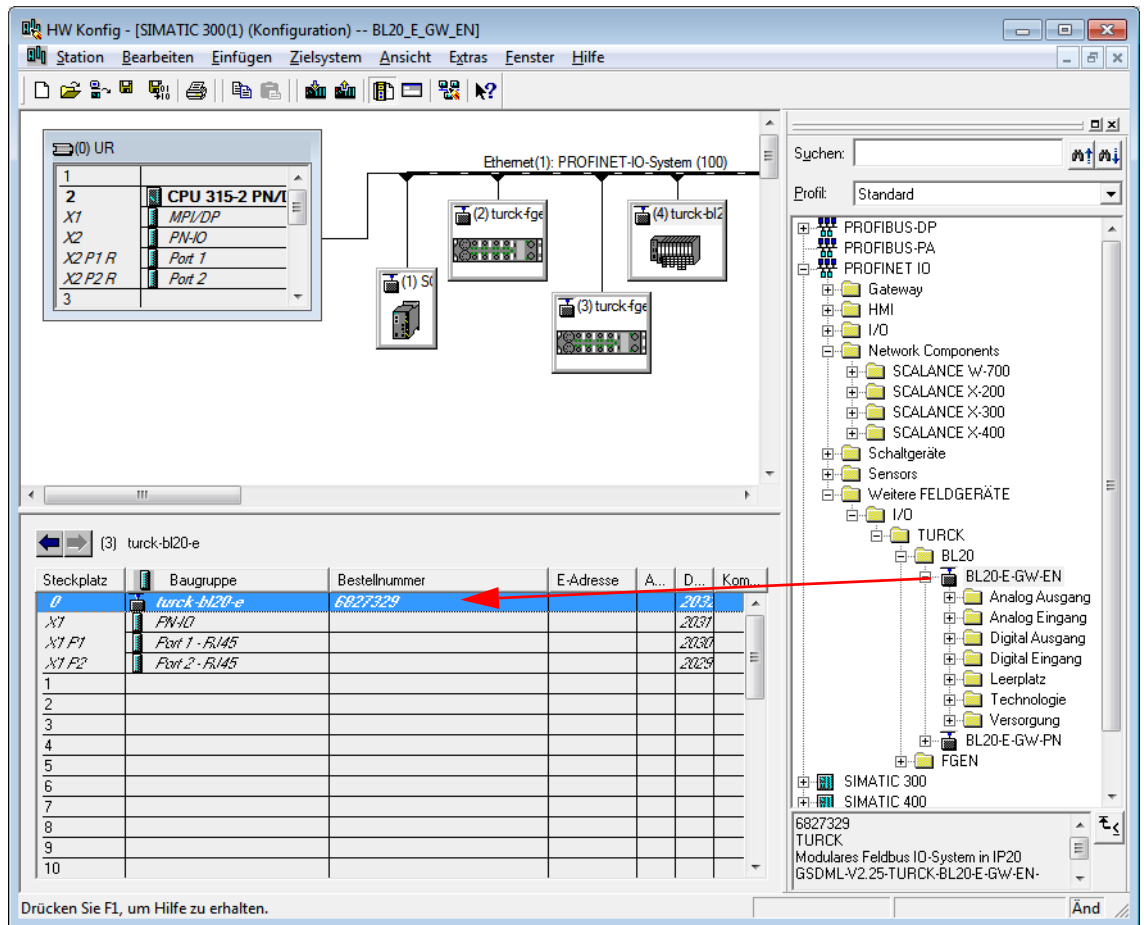

- 2 A double-click on the gateway-symbol opens the dialog "Properties TURCK".

3 Enter the gateway's device name in this dialog.

Figure 9-11:
Dialog:
Properties
TURCK

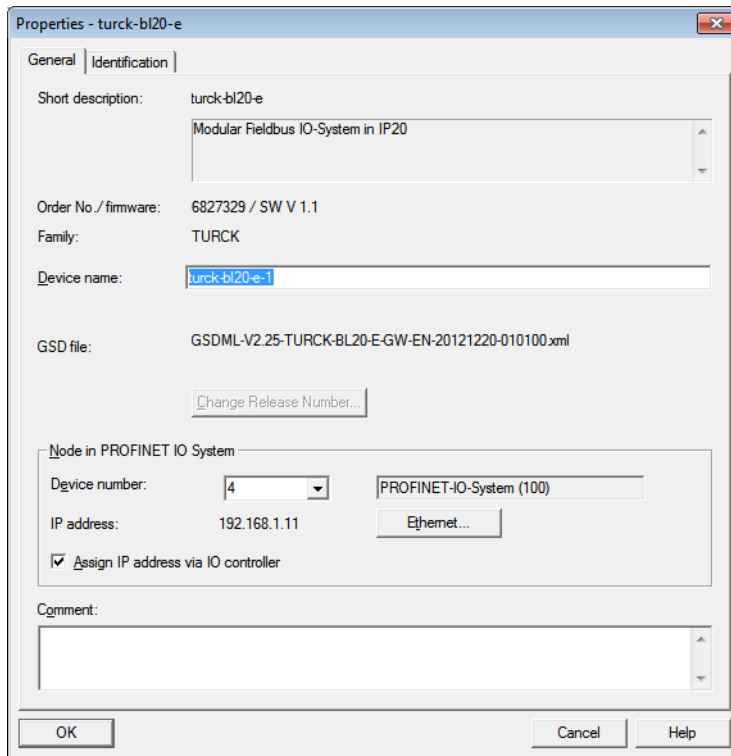

Note

In PROFINET®, the connected device is not identified by its IP address, but recognized and addressed by its device name. The selection of a device name for a special IO device can thus be compared to the setting of the PROFIBUS address for a DP slave.



Note

When storing the device name or the IP address or when resetting the gateway to the default values, the GW-LED switches to orange. During this time, the gateway's voltage supply must not be interrupted. In case of a power failure, faulty data will be stored in the gateway.

9.1.7 Configuring the BL20-station

After the assignment of the device name, the I/O modules, which are connected to the BL20 gateway, are added to the station. They have to be selected from the Hardware Catalog in the same order as they appear physically in the station.

Figure 9-12:
Add I/O-
modules to the
station
Add a station

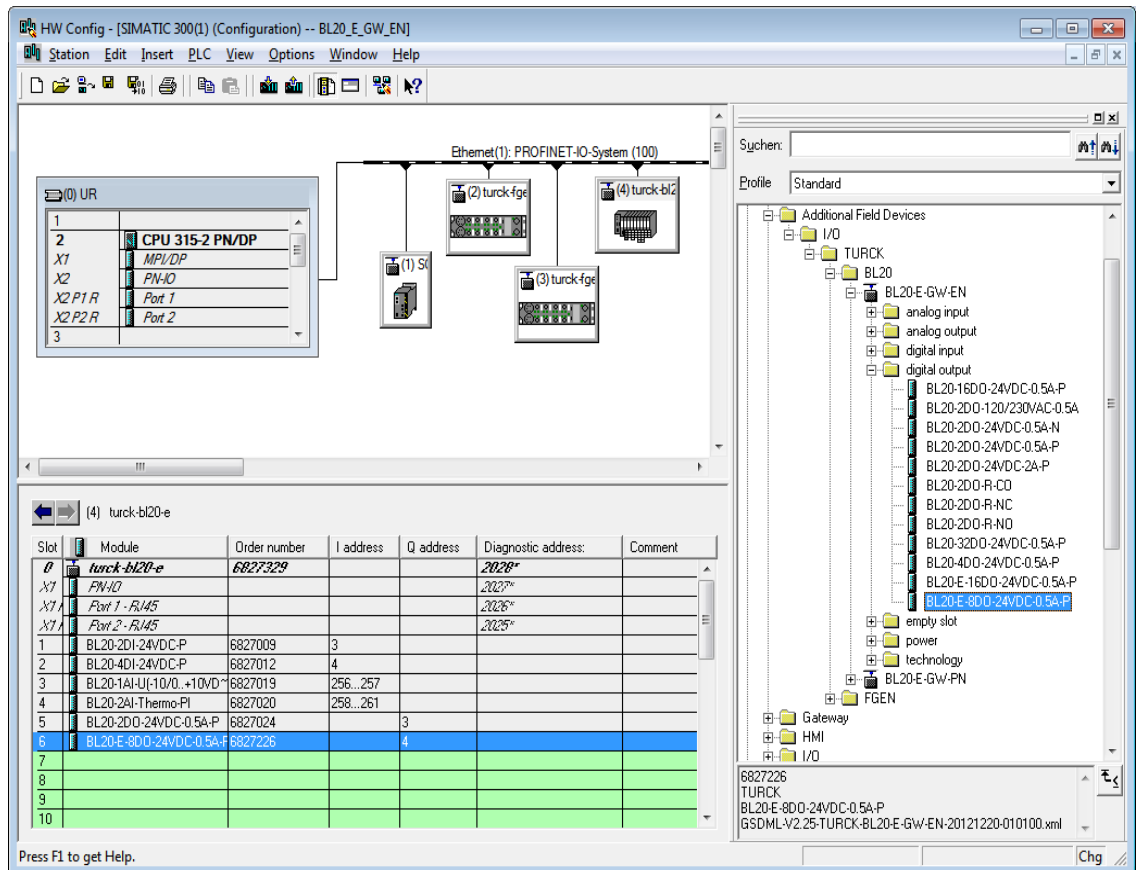

1 Save your hardware configuration via "Station → Save and Compile"

2 and download it to the PLC via "PLC → Download..." command.

The hardware configuration is completed.



Note

If changes in the configuration of a node are made after the download of the configuration and the starting of the PLC, PROFINET® requires a reset for the respective device.

This can be done following different ways:

Hardware reset:

- F_RESET at the gateway (see also [F_Reset \(Reset to factory setting\)](#) (page 3-22))

Software reset:

- HW Config: "PLC → Ethernet → Edit Ethernet Node... → Browse", select a node and execute the reset in the dialog box "Edit Ethernet Node..." via "Reset".
- other PROFINET®-tool (PST-tool from Siemens, etc.)

9.1.8 Scanning the network for PROFINET® nodes

The Simatic hardware configuration offers the possibility to browse the PROFINET® network using a broadcast command in order to find active PROFINET® nodes. The active nodes are identified via their MAC address.

- 1 Open the respective dialog box by using "PLC → Ethernet → Edit Ethernet Node".

Figure 9-13:
Configure
Ethernet node

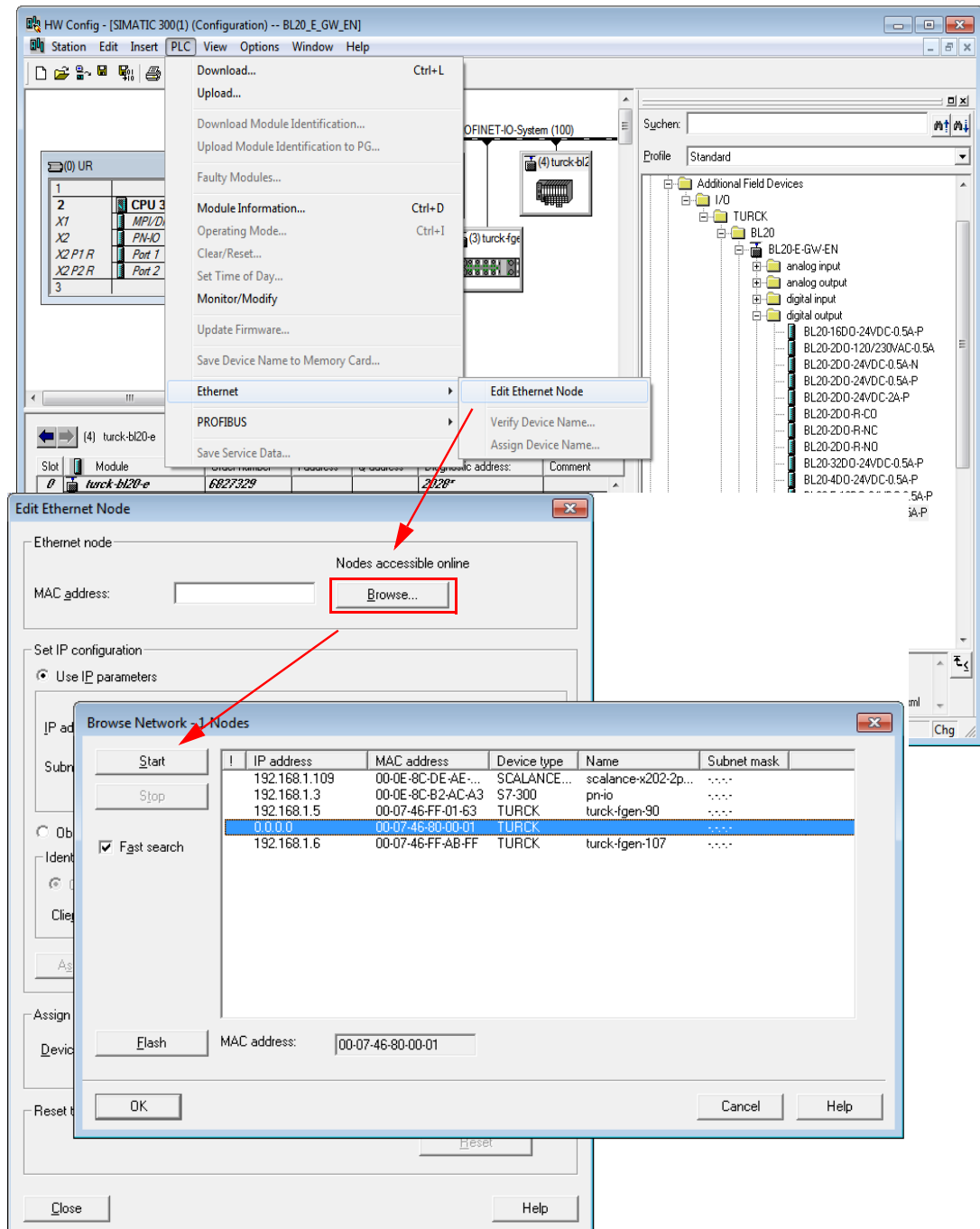

- 2 Browse the network for active network nodes identified by means of their MAC address, by using the button "Browse" in the field "Ethernet node".
All PROFINET® nodes found in the network answer the command sending their MAC address and their device name.

- 3 Select a node and close the dialog with "OK".
The features of the selected node are now shown in the in the dialog "Edit Ethernet Node".

Device name assignment BL20-gateway

If necessary, the device name can now be changed to the needs of the application.

In this example, the following name is assigned to the BL20-gateway:

- Device name: turck-bl20-e-1

Figure 9-14:
Adaptation of
the Ethernet
node configura-
tion

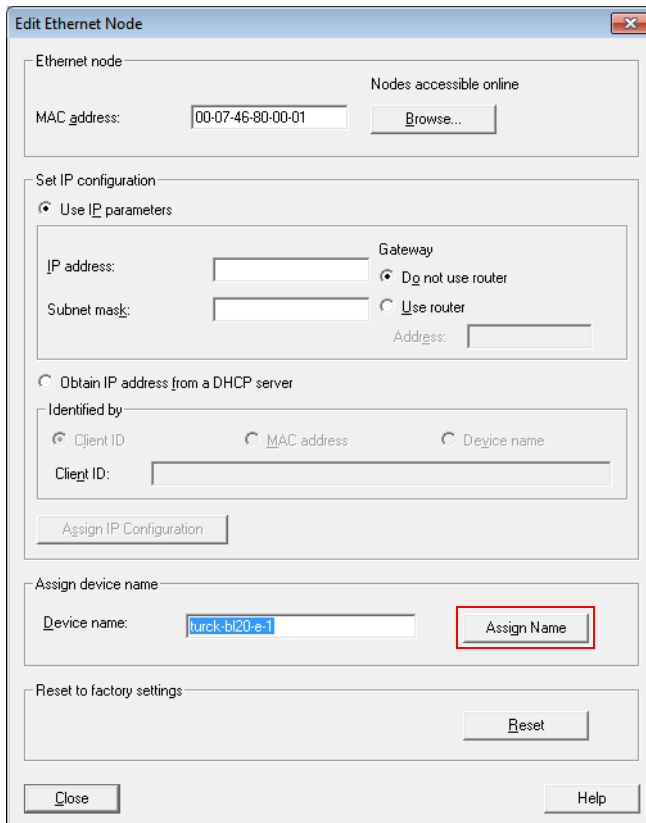

Note

Here, you can also assign an application specific device name to the devices which were found.
Please observe, that the device name assigned here has to be similar to the device name assigned to the node in the properties dialog box (see [Figure 9-11: Dialog: Properties TURCK](#)).
If this is not guaranteed, the PLC will not be able to clearly identify the node!

9.1.9 PROFINET® neighborhood detection via LLDP

Due to the neighborhood detection, there is no previous PROFINET® name assignment (see [Device name assignment BL20-gateway \(page 9-13\)](#)) is necessary for a new device of the same type and with an identical process data width in case of a device exchange. The device name and the IP-address will be assigned to the new device by the neighbor-device configured before (see [Configuring the neighborhood detection \(page 9-15\)](#)).

Necessary setting of the PROFINET®-controller

The neighborhood detection without using a PC or removable media can only be executed if the function "Support device replacement without exchangeable medium" is activated within the properties of the PROFINET®-controller.

Figure 9-15:
Settings of the
PROFINET®-
controller

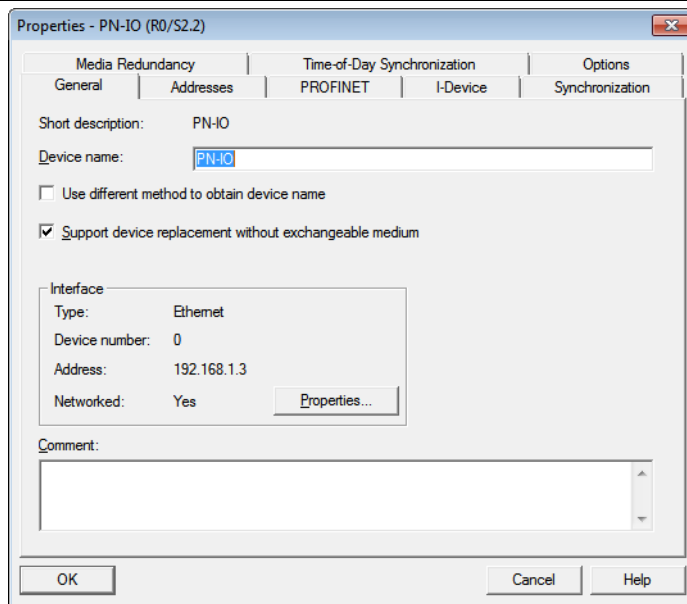

In case of a device exchange, a new device thus not receives the device name from the removable medium or the PG but from the IO-controller.

The device name is assigned by means of the devices' port interconnections configured in the topology definition.

Configuring the neighborhood detection

A neighbor-port can be assigned to each Ethernet-port of a device. In case of a device exchange, this port is then used to assign the IP-address and the device name to the new device.

The definition of the partner-port is done either in the properties of the devices' Ethernet-ports or directly in the PROFINET® Topology Editor (see [page 9-16](#)).

- Partner-port definition via port-configuration.
Selection of the port at the neighboring device to which this port is physically connected.

Figure 9-16:
Partner-port
definition
(Example)

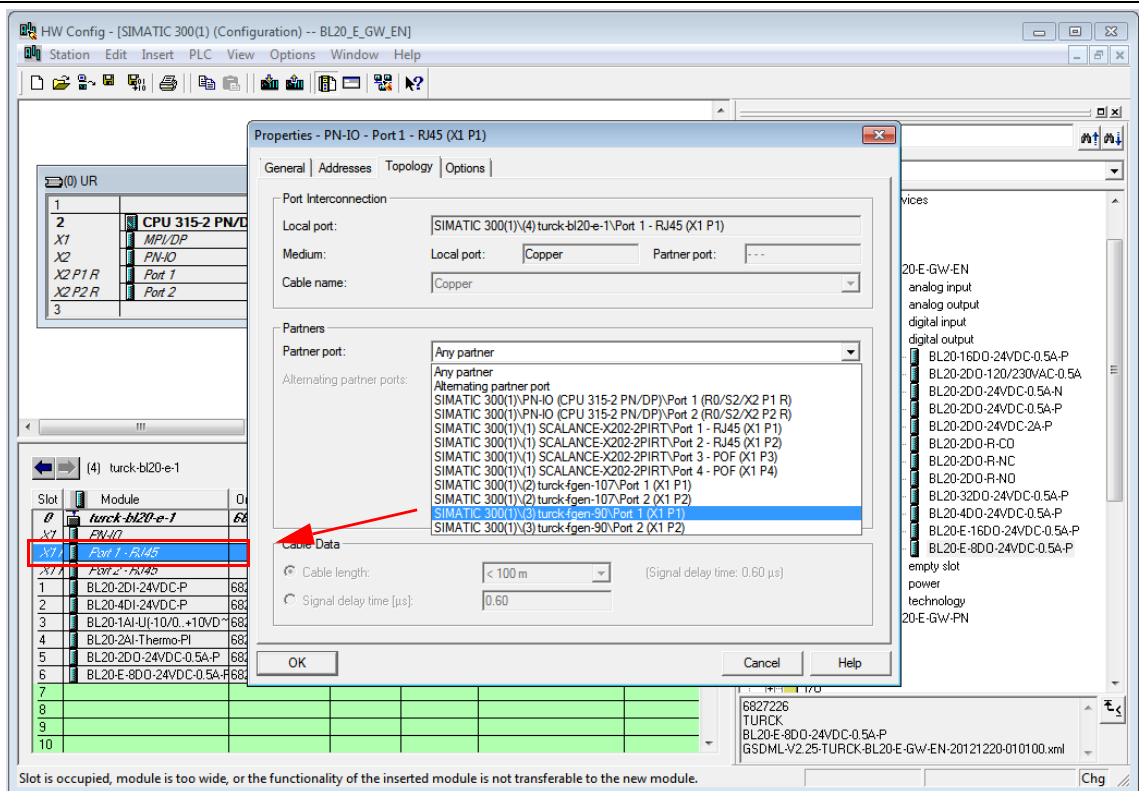

- Neighborhood-assignment using the Topology Editor.
The assignment of neighboring devices is done either in the tabular or the graphical view.
The copper ports of the devices are shown in green, the fiber-optic-ports in orange.

Figure 9-17:
PROFINET®
Topology Editor

- A** Example: copper port
- B** fiber optic port
- C** Example: copper connection

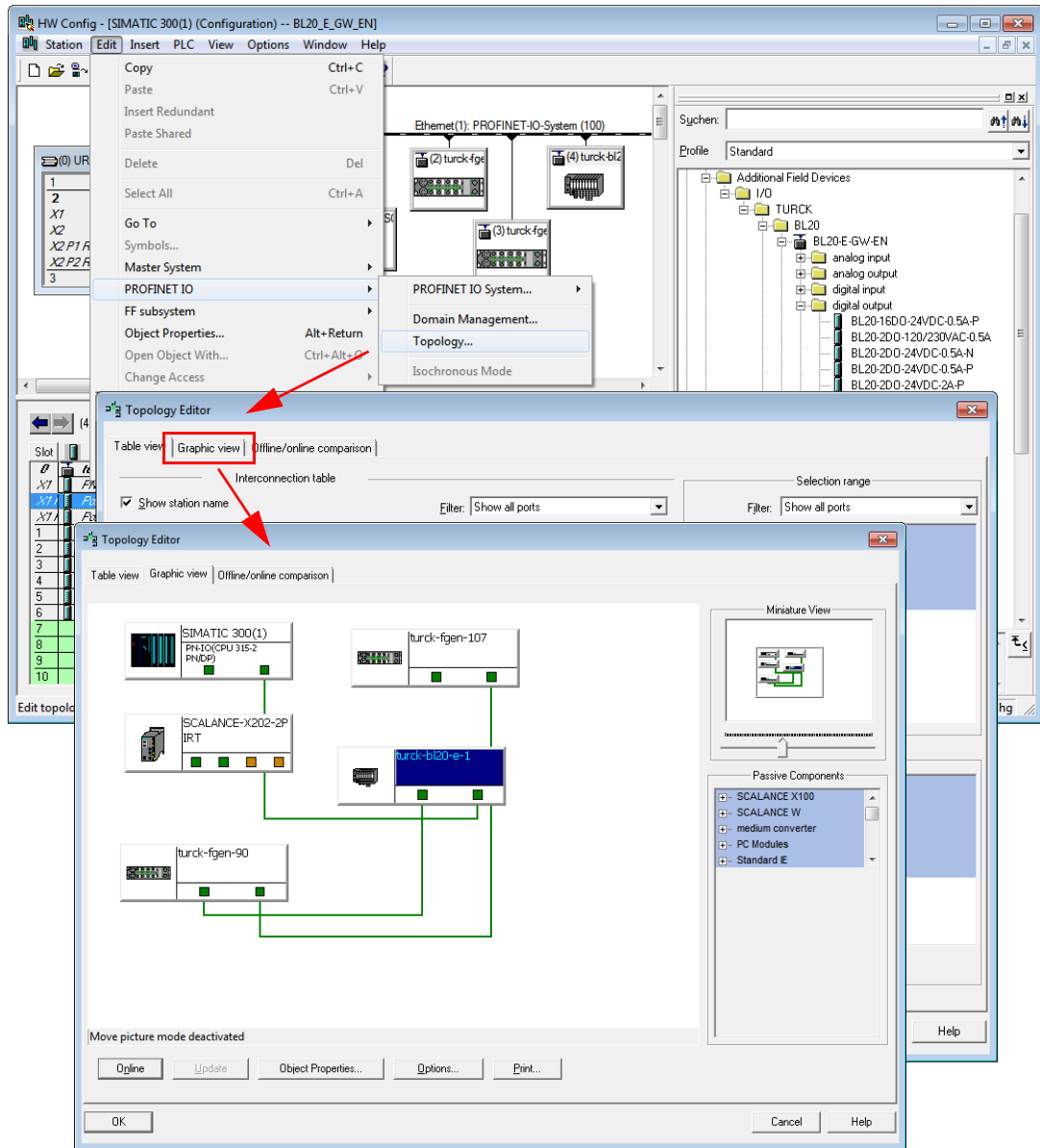

9.1.10 Online topology detection

The Step 7 software allows an offline/online comparison of the configured and the actually present topology.

- 1 Start the "Offline/ online comparison" in the Topology Editor using the "Start"-button in the respective tab.

Figure 9-18:
PROFINET®
Topology Editor
Offline/ online
comparison

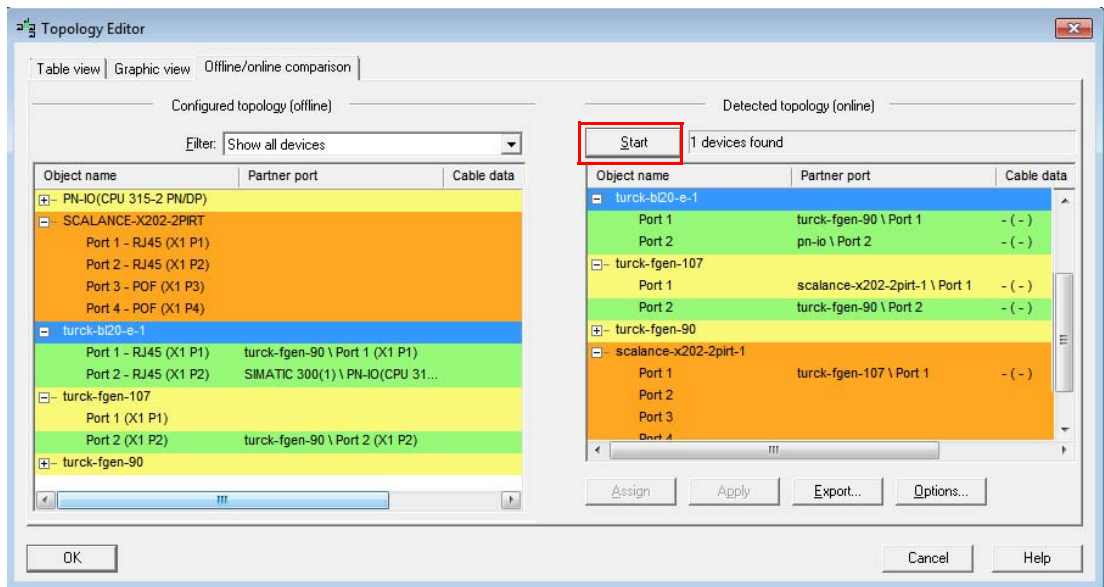

9.2 Diagnostics with Step 7

9.2.1 Diagnostic messages in the hardware configuration

The BL20 gateways for PROFINET® show gateway diagnostics and channel-specific module diagnostics in the hardware configuration of the Step 7-software.

Furthermore a special help text, which clearly specifies the error, is given for each diagnostic message:

Figure 9-19:
Diagnostics

- A** channel-specific module diagnostics
- B** manufacturer specific help texts

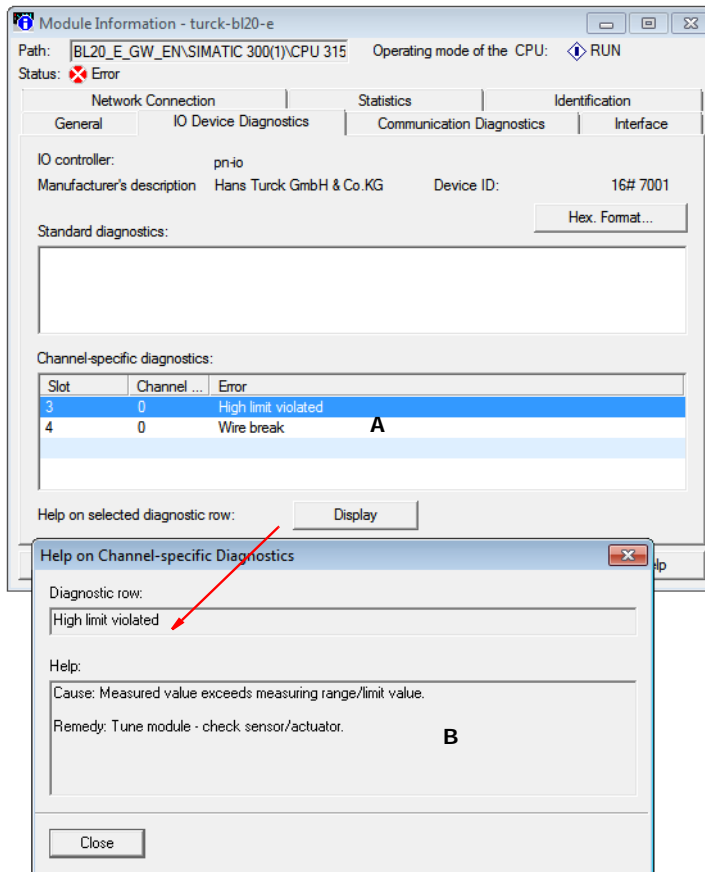

9.2.2 Diagnostic telegram with error code

Figure 9-20:
Diagnostic message

- A** slot-no.
- B** subslot-no.
- C** error code
- D** plaint text diagnostic message

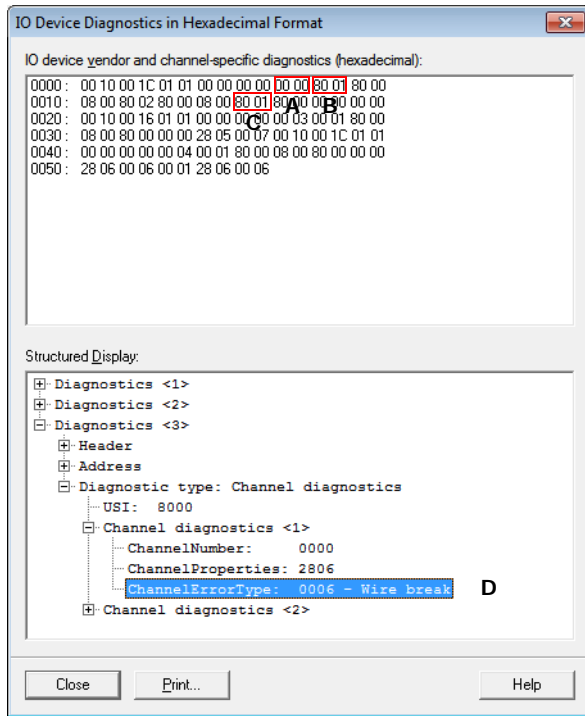

10 Guidelines for station planning

10.1	Module arrangement	10-2
10.1.1	Random module arrangement.....	10-2
10.1.2	Complete planning.....	10-2
10.1.3	Maximum system extension	10-3
10.2	Power supply	10-6
10.2.1	Power supply to the gateway	10-6
10.2.2	Module bus refreshing (BL20-BR-24VDC-D)	10-6
10.2.3	Creating potential groups.....	10-7
10.2.4	C-rail (cross connection)	10-7
10.2.5	Direct wiring of relay modules	10-9
10.3	Protecting the service interface on the gateway	10-10
10.4	Plugging and pulling electronics modules	10-10
10.5	Extending an existing station	10-10
10.6	Firmware download	10-11

10.1 Module arrangement

10.1.1 Random module arrangement

The arrangement of the I/O-modules within a BL20 station can basically be chosen at will. Nevertheless, it can be useful with some applications to group certain modules together.



Note

A mixed usage of gateways of the BL20 ECO and the BL20 standard product line and I/O modules of both product lines (base modules with tension clamp terminals) is possible without any problems.

Figure 10-1:
Example of a station structure with ECO gateway (here for CANopen), ECO and standard I/O modules

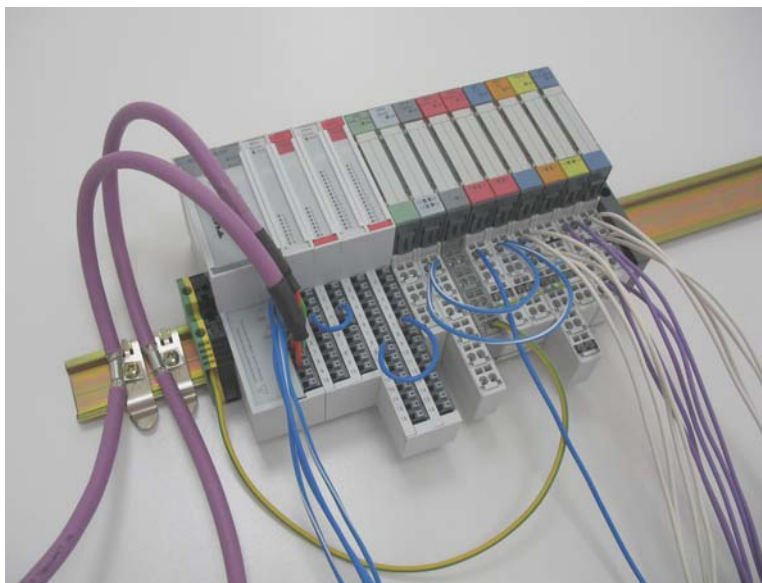

Note

Next to the gateway, only base modules with tension clamp terminals and ECO-modules can be used.

Base modules with screw terminals can only be used, if a power supply module (BR or PF) with screw terminals was set before.

10.1.2 Complete planning

The planning of a BL20 station should be thorough to avoid faults and increase operating reliability.



Attention

If there are more than two empty slots next to one another, the communication is interrupted to all following BL20 modules.

The power to BL20 systems is supplied from a common external source. This avoids the occurrence of potential compensating currents within the BL20 station.

10.1.3 Maximum system extension

The maximum number of modules connected to the gateway BL20-E-GW-EN depends on the following:

- The station extension may not exceed the maximum number of **32 modules**.
- Die maximum number of **192** communications bytes, which are transferred via the module bus from the gateway to the modules may not be exceeded (see below [Table 10-1: Communication bytes and nominal current consumption of the BL20-modules](#)).
- If the maximum sum of the modules' nominal current consumptions (see below [Table 10-1: Communication bytes and nominal current consumption of the BL20-modules](#)) right to the gateway (max. sum $\Sigma I_{MB} = 400 \text{ mA}$) is reached, a Bus Refreshing module has to be used in order to provide the module bus voltage.
To the right of the Bus Refreshing module, the sum of the modules' current consumptions can amount to **1,5 A**.



Attention

Ensure that a sufficient number of Bus Refreshing and Power Feeding modules are used if the system is extended to its maximum.



Note

If the system limits are exceeded, the software I/O-ASSISTANT 3 (FDT/DTM) generates an error message when the user activates the command "Verify station".

For the calculation of the maximum system extension, the following table contains an overview about the modules' nominal current consumptions.

Table 10-1:
Communication bytes and nominal current consumption of the BL20-modules

Module	Communication bytes (on the module bus)	Nominal current consumption at the module bus
BL20-PF-24VDC-D	2	28 mA
BL20-PF-120/230VAC-D	2	25 mA
BL20-2DI-24VDC-P	1	28 mA
BL20-2DI-24VDC-N	1	28 mA
BL20-2DI-120/230VAC	1	28 mA
BL20-4DI-24VDC-P	1	29 mA
BL20-4DI-24VDC-N	1	28 mA
BL20-4DI-NAMUR	5	40 mA
BL20-E-8DI-24VDC-P	1	15 mA
BL20-E-16DI-24VDC-P	2	15 mA
BL20-16DI-24VDC-P	2	45 mA

*Table 10-1:
Communication bytes and
nominal current
consumption of
the BL20-
modules*

Module	Communication bytes (on the module bus)	Nominal current consumption at the module bus
BL20-32DI-24VDC-P	4	30 mA
BL20-1AI-I(0/4...20MA)	3	41 mA
BL20-2AI-I(0/4...20MA)	5	35 mA
BL20-1AI-U(-10/0...+10VDC)	3	41 mA
BL20-2AI-U(-10/0...+10VDC)	5	35 mA
BL20-2AI-PT/NI-2/3	5	45 mA
BL20-2AI-THERMO-PI	5	45 mA
BL20-4AI-U/I	9	30 mA
BL20-E-8AI-U/I-4AI-PT/NI	9	50 mA
BL20-2DO-24VDC-0.5A-P	2	32 mA
BL20-2DO-24VDC-0.5A-N	2	32 mA
BL20-2DO-24VDC-2A-P	2	33 mA
BL20-2DO-120/230VAC-0.5A	2	35 mA
BL20-4DO-24VDC-0.5A-P	2	30 mA
BL20-E-8DO-24VDC-0.5A-P	2	15 mA
BL20-E-16DO-24VDC-0.5A-P	2	25 mA
BL20-16DO-24VDC-0.5A-P	3	120 mA
BL20-32DO-24VDC-0.5A-P	5	30 mA
BL20-1AO-I(0/4...20MA)	4	39 mA
BL20-2AO-I(0/4...20MA)	7	40 mA
BL20-2AO-U(-10/0...+10VDC)	7	43 mA
BL20-E-4AO-U/I	9	50 mA
BL20-2DO-R-NC	1	28 mA
BL20-2DO-R-NO	1	28 mA
BL20-2DO-R-CO	1	28 mA
BL20-E-2CNT/2PWM	9	30 mA
BL20-1RS232	9	140 mA
BL20-1RS485/422	9	60 mA

Table 10-1: Communication bytes and nominal current consumption of the BL20-modules

Module	Communication bytes (on the module bus)	Nominal current consumption at the module bus
BL20-1SSI	9	50 mA
BL20-2RFID-x	9	30 mA
BL20-E-1SWIRE	9	60 mA

10.2 Power supply

10.2.1 Power supply to the gateway

The gateway BL20-E-GW-EN offers an integrated power supply (see also [Power supply \(page 3-14\)](#)).

10.2.2 Module bus refreshing (BL20-BR-24VDC-D)

The number of BL20 modules, which can be supplied via the internal module bus by the gateway or a Bus Refreshing module depends on the modules' nominal current consumptions at the module bus [Table 10-1: Communication bytes and nominal current consumption of the BL20-modules, page 10-3](#)).



Attention

The sum of the nominal current consumptions (see [Table 10-1: Communication bytes and nominal current consumption of the BL20-modules, page 10-3](#)) of the used BL20 modules may not exceed 400 mA.

If a Bus Refreshing module is mounted, the sum of the current consumptions which follow the Bus Refreshing module must not exceed 1,5 A.



Note

The Bus Refreshing modules which are used in a station with BL20-E-GW-EC have to be combined with the base modules BL20-P3T-SBB-B or BL20-P4T-SBBC-B (tension clamp) or with the base modules BL20-P3S-SBB-B or BL20-P4S-SBBC-B (screw terminals).

With the system supply, it must be ensured that the same ground potential and ground connections are used. Compensating currents flow via the module bus if different ground potentials or ground connections are used, which can lead to the destruction of the Bus Refreshing module.

All Bus Refreshing modules are connected to one another via the same ground potential.

The power to the module bus is supplied via the connections 11 and 21 on the base module.

If the power supply from the module bus is not guaranteed, the software I/O-ASSISTANT 3 (FDT/DTM) generates an error message if the user activates the DTM "Additional functions → Verify station".

10.2.3 Creating potential groups

Power Feeding modules can be used to create potential groups. The potential isolation of potential groups to the left of the respective power distribution modules is provided by the base modules.



Note

The system can be supplied with power independent of the potential group formation.

When using a digital input module for 120/230 V AC, it should be ensured that a potential group is created in conjunction with the Power Feeding module BL20-PF-120/230VAC-D.



Attention

It is not permitted to use modules with 24 V DC and 120/230 V AC field supply in a joint potential group.

10.2.4 C-rail (cross connection)

The C-rail runs through all base modules. The C-rail of the base modules for power distribution modules is mechanically separated; thus potentially isolating the adjoining supply groups.

Access to the C-rail is possible with the help of base modules with a C in their designation (for example, BL20-S4T-SBCS). The corresponding connection level is indicated on these modules by a thick black line. The black line is continuous on all I/O modules.

On power distribution modules, the black line is only above the connection 24. This makes clear that the C-rail is separated from the adjoining potential group to its left.

Figure 10-2:
C-rail
(front view)



Figure 10-3:
C-rail
(side view)

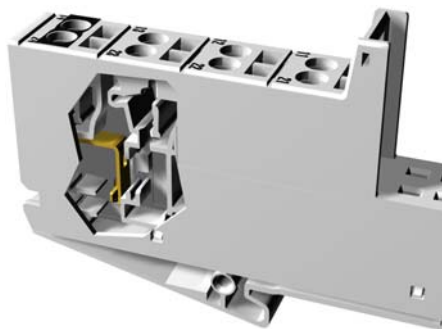



Warning

It is permitted to load the C-rail with a maximum of 24 V. Not 230 V!

The C-rail can be used as required by the application, for example, as a protective earth (PE). In this case, the PE connection of each power distribution module must be connected to the mounting rail via an additional PE terminal, which is available as an accessory.

The C-rail is not interrupted by the modules of the BL20-ECO-products. It is connected through the modules' connection level. But, an access to the C-rail is not possible.



Note

For information about introducing a BL20 station into a ground reference system, please read [chapter 10](#).

Figure 10-4:
Using the C-rail
as a protective
earth

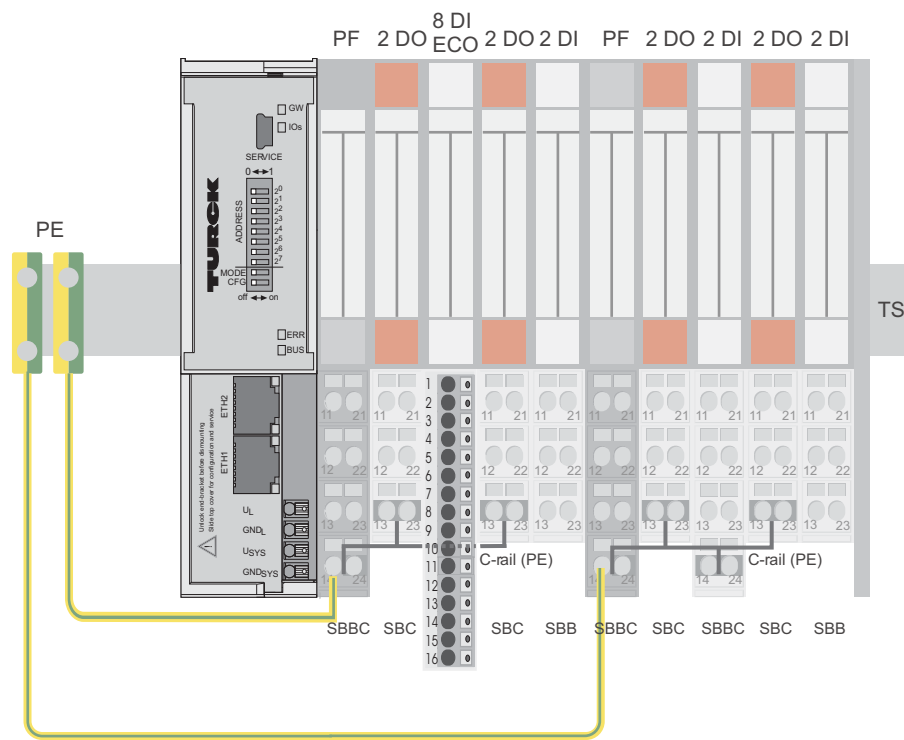

C-rails can be used for a common voltage supply (24 V DC) when relay modules are planned. To accomplish this, the load voltage is connected to a Power Feeding module with the BL20-P4x-SBBC base module. All the following relay modules are then supplied with power via the C-rail.



Attention

When relay modules are planned and the C-rail is used for a common voltage supply, a further power distribution module must be used for the potential isolation to the following modules. The C-rail can only again be used as a PE following potential isolation.

Figure 10-5:
Using the C-rail
as protective
earth and for
the power
supply with
relay modules

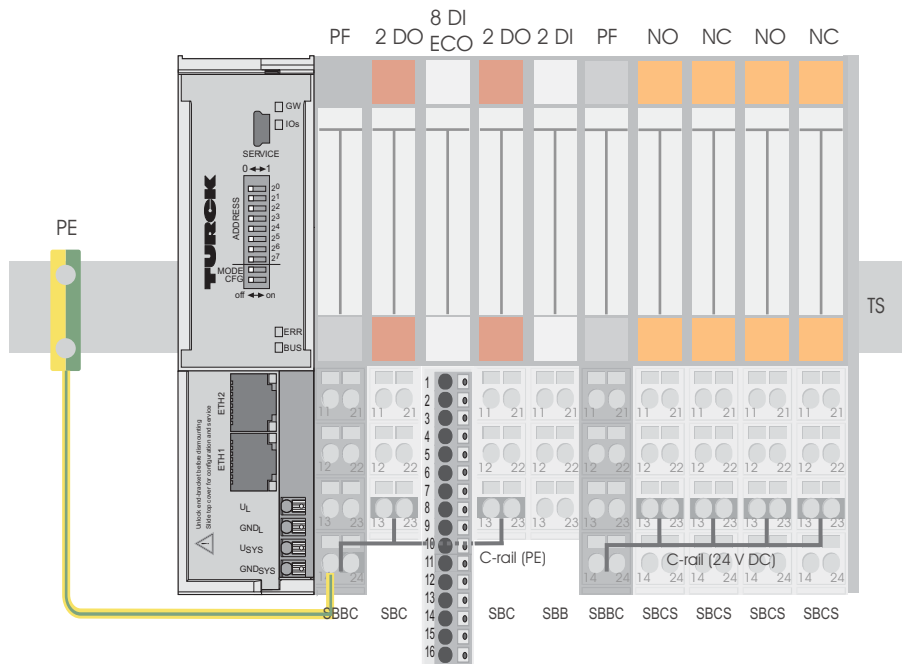

Cross-connecting relay module roots is achieved by the use of jumpers. The corresponding wiring diagram including the jumpers can be found the manuals for BL20 I/O modules (German: D300716, English: D300717).

10.2.5 Direct wiring of relay modules

As well as the options mentioned above, relay modules can be wired directly. In this case, base modules without C-rail connections should be chosen to guarantee the potential isolation to the adjoining modules.

10.3 Protecting the service interface on the gateway

During operation, the label protecting the service interface and the DIP-switches must remain in place due to EMC and ESD requirements.

10.4 Plugging and pulling electronics modules

BL20 enables the pulling and plugging of electronics modules without having to disconnect the field wiring. The BL20 station remains in operation if an electronics module is pulled. The voltage and current supplies as well as the protective earth connections are not interrupted



Attention

If the field and system supplies remain connected when electronics modules are plugged or pulled, short interruptions to the module bus communications can occur in the BL20 station. This can lead to undefined statuses of individual inputs and outputs of different modules.

10.5 Extending an existing station



Attention

Please note that extensions to the station (mounting further modules) should be carried out only when the station is in a voltage-free state.

10.6 Firmware download

The firmware download to BL20-E-GW-EN (< VN 03-00) using the software I/O-ASSISTANT 3 (FDT/DTM) can only be executed via Ethernet.

The download using the USB-interface is not supported.

More information is available in the program's online help.



Attention

- The station should be disconnected from the fieldbus when downloading.
 - Firmware must be downloaded by authorized personnel only.
 - The field level must be isolated.
-

Guidelines for station planning

11 Guidelines for Electrical Installation

11.1	General notes	11-2
11.1.1	General.....	11-2
11.1.2	Cable routing	11-2
	– Cable routing inside and outside of cabinets.....	11-2
	– Cable routing outside buildings	11-3
11.1.3	Lightning protection.....	11-3
11.1.4	Transmission media.....	11-3
11.2	Potential relationships	11-4
11.2.1	General.....	11-4
11.3	Electromagnetic compatibility(EMC.....	11-5
11.3.1	Ensuring electromagnetic compatibility	11-5
11.3.2	Grounding of inactive metal components.....	11-5
11.3.3	PE connection.....	11-5
11.3.4	Earth-free operation.....	11-5
11.3.5	Mounting rails	11-6
11.4	Shielding of cables	11-7
11.5	Potential compensation	11-8
11.5.1	Switching inductive loads.....	11-8
11.5.2	Protection against Electrostatic Discharge (ESD)	11-8

11.1 General notes

11.1.1 General

Cables should be grouped together, for example: signal cables, data cables, heavy current cables, power supply cables.

Heavy current cables and signal or data cables should always be routed in separate cable ducts or bundles. Signal and data cables must always be routed as close as possible to ground potential surfaces (for example support bars, cabinet sides etc.).

11.1.2 Cable routing

Correct cable routing prevents or suppresses the reciprocal influencing of parallel routed cables.

Cable routing inside and outside of cabinets

To ensure EMC-compatible cable routing, the cables should be grouped as follows:

Various types of cables within the groups can be routed together in bundles or in cable ducts.

Group 1:

- shielded bus and data cables
- shielded analog cables
- unshielded cables for DC voltage ≤ 60 V
- unshielded cables for AC voltage ≤ 25 V

Group 2:

- unshielded cables for DC voltage > 60 V and ≤ 400 V
- unshielded cables for AC voltage > 25 V and ≤ 400 V

Group 3:

- unshielded cables for DC and AC voltages > 400 V

The following group combination can be routed only in separate bundles or separate cable ducts (no minimum distance apart):

- Group 1/Group 2

The group combinations:

Group 1/Group 3 and Group 2/Group 3

must be routed in separate cable ducts with a minimum distance of 10 cm apart. This is equally valid for inside buildings as well as for inside and outside of switchgear cabinets.

Cable routing outside buildings

Outside of buildings, cables should be routed in closed (where possible), cage-type cable ducts made of metal. The cable duct joints must be electrically connected and the cable ducts must be earthed.



Danger

Observe all valid guidelines concerning internal and external lightning protection and grounding specifications when routing cables outside of buildings.

11.1.3 Lightning protection

The cables must be routed in double-grounded metal piping or in reinforced concrete cable ducts.

Signal cables must be protected against overvoltage by varistors or inert-gas filled overvoltage arrestors. Varistors and overvoltage arrestors must be installed at the point where the cables enter the building.

11.1.4 Transmission media

For a communication via Ethernet, different transmission media can be used:

- coaxial cable
10Base2 (thin coax),
10Base5 (thick coax, yellow cable)
- optical fiber (10BaseF)
- twisted two-wire cable (10BaseT) with shielding (STP) or without shielding (UTP)



Note

TURCK offers a variety of cable types for fieldbus lines as premoulded or bulk cables with different connectors.

The ordering information on the available cable types can be taken from the BL20-catalog.

11.2 Potential relationships

11.2.1 General

The potential relationship of a Ethernet system realized with BL20 modules is characterized by the following:

- The system supply of gateway and I/O-modules as well as the field supply are realized via one power feed at the gateway.
- All BL20 modules (gateway, Power Feeding and I/O-modules), are connected capacitively via base modules to the mounting rails.

The block diagram shows the arrangement of a typical BL20 station with Ethernet gateway.

Figure 11-1:
Block diagram
of a BL20 station
with
PROFINET®-
gateway

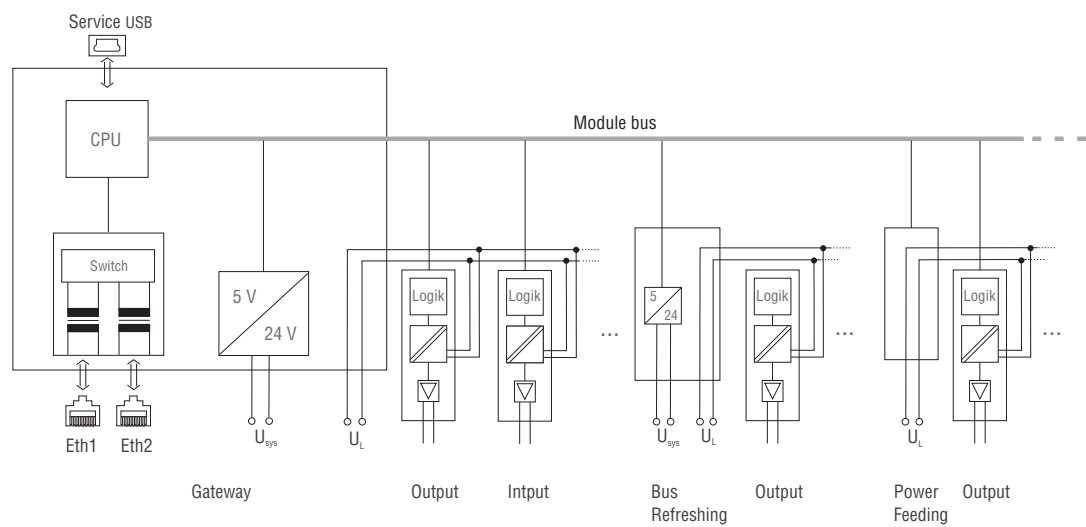

11.3 Electromagnetic compatibility(EMC)

BL20 products comply in full with the requirements pertaining to EMC regulations. Nevertheless, an EMC plan should be made before installation.

Hereby, all potential electromechanical sources of interference should be considered such as galvanic, inductive and capacitive couplings as well as radiation couplings.

11.3.1 Ensuring electromagnetic compatibility

The EMC of BL20 modules is guaranteed when the following basic rules are adhered to:

- Correct and large surface grounding of inactive metal components.
- Correct shielding of cables and devices.
- Proper cable routing – correct wiring.
- Creation of a standard reference potential and grounding of all electrically operated devices.
- Special EMC measures for special applications.

11.3.2 Grounding of inactive metal components

All inactive metal components (for example: switchgear cabinets, switchgear cabinet doors, supporting bars, mounting plates, tophat rails, etc.) must be connected to one another over a large surface area and with a low impedance (grounding). This guarantees a standardized reference potential area for all control elements and reduces the influence of coupled disturbances.

- In the areas of screw connections, the painted, anodized or isolated metal components must be freed of the isolating layer. Protect the points of contact against rust.
- Connect all free moving groundable components (cabinet doors, separate mounting plates, etc.) by using short bonding straps to large surface areas.
- Avoid the use of aluminum components, as its quick oxidizing properties make it unsuitable for grounding.



Warning

The grounding must never – including cases of error – take on a dangerous touch potential. For this reason, always protect the ground potential with a protective cable.

11.3.3 PE connection

A central connection must be established between ground and PE connection (protective earth).

11.3.4 Earth-free operation

Observe all relevant safety regulations when operating an earthfree system. PE connection

11.3.5 Mounting rails

All mounting rails must be mounted onto the mounting plate with a low impedance, over a large surface area, and must be correctly earthed. Use corrosion-resistant mounting rails

Figure 11-2:
Mounting options

- A** TS 35
- B** mounting rail
- C** mounting plate

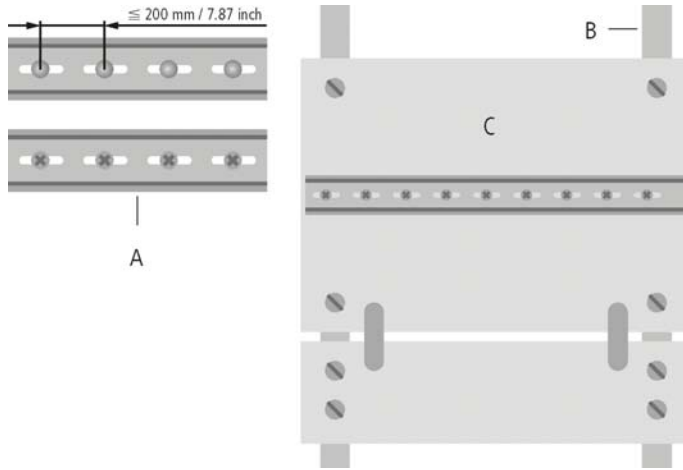

Mount the mounting rails over a large surface area and with a low impedance to the support system using screws or rivets.

Remove the isolating layer from all painted, anodized or isolated metal components at the connection point. Protect the connection point against corrosion (for example with grease; caution: use only suitable grease).

11.4 Shielding of cables

Shielding is used to prevent interference from voltages and the radiation of interference fields by cables. Therefore, use only shielded cables with shielding braids made from good conducting materials (copper or aluminum) with a minimum degree of coverage of 80 %.

The cable shield should always be connected to both sides of the respective reference potential (if no exception is made, for example, such as high-resistant, symmetrical, analog signal cables). Only then can the cable shield attain the best results possible against electrical and magnetic fields.

A one-sided shield connection merely achieves an isolation against electrical fields.



Attention

When installing, please pay attention to the following...

- the shield should be connected immediately when entering the system,
 - the shield connection to the shield rail should be of low impedance,
 - the stripped cable-ends are to be kept as short as possible,
 - the cable shield is not to be used as a bonding conductor.
-

The insulation of the shielded data-cable should be stripped and connected to the shield rail when the system is used in stationary operation. The connection and securing of the shield should be made using metal shield clamps. The shield clamps must enclose the shielding braid and in so doing create a large surface contact area. The shield rail must have a low impedance (for example, fixing points of 10 to 20 cm apart) and be connected to a reference potential area.

The cable shield should not be severed, but routed further within the system (for example, to the switchgear cabinet), right up to the interface connection.



Note

Should it not be possible to ground the shield on both sides due to switching arrangements or device specific reasons, then it is possible to route the second cable shield side to the local reference potential via a capacitor (short connection distances). If necessary, a varistor or resistor can be connected parallel to the capacitor, to prevent disruptive discharges when interference pulses occur.



Note

A further possibility is a double-shielded cable (galvanically separated), whereby the innermost shield is connected on one side and the outermost shield is connected on both sides.

11.5 Potential compensation

Potential differences can occur between installation components that are in separate areas if these

- are fed by different supplies,
- have double-sided conductor shields which are grounded on different installation components.

A potential-compensation cable must be routed to the potential compensation.



Warning

Never use the shield as a potential compensation.

A potential compensation cable must have the following characteristics:

- Low impedance. In the case of compensation cables that are routed on both sides, the compensation line impedance must be considerably smaller than that of the shield connection (max. 10 % of shield connection impedance).
- Should the length of the compensation cable be less than 200 m, then its cross-section must be at least 16 mm² / 0.025 inch². If the cable length is greater than 200 m, then a cross-section of at least 25 mm² / 0.039 inch² is required.
- The compensation cable must be made of copper or zinc coated steel.
- The compensation cable must be connected to the protective conductor over a large surface area and must be protected against corrosion.
- Compensation cables and data cables should be routed as close together as possible, meaning the enclosed area should be kept as small as possible.

11.5.1 Switching inductive loads

In the case of inductive loads, a protective circuit on the load is recommended.

11.5.2 Protection against Electrostatic Discharge (ESD)



Attention

Electronic modules and base modules are at risk from electrostatic discharge when disassembled. Avoid touching the bus connections with bare fingers as this can lead to ESD damage.

12 BL20-Approvals for Zone 2/ Division 2



Note

The Zone 2 - approval certificates for BL20 can be found in a separate manual for approvals D301255 under www.turck.de.

13 Appendix

13.1	Data image of the technology modules	13-2
13.1.1	1RS232/ 1RS485-module	13-2
	– Process input data	13-2
	– Process output data	13-4
13.1.2	SSI module	13-6
	– Process input data	13-6
	– Process output data	13-11
13.1.3	SWIRE-module	13-13
	– SWIRE in Modbus	13-13
	– Process input data	13-13
	– Process output data	13-14
13.1.4	Encoder/PWM-module BL20-E-2CNT-2PWM	13-15
13.1.5	RFID-module BL20-2RFID-S/ -A	13-15
13.2	Changing the IP address of a PC/ network interface card	13-16
13.2.1	Changing the IP address in Windows	13-16
13.2.2	Changing the IP address via I/O-ASSISTANT V3	13-18
13.3	Deactivating/ adapting the firewall in Windows	13-19
13.4	Addressing via DHCP	13-22
13.5	Ident codes the BL20-modules	13-24

13.1 Data image of the technology modules

13.1.1 1RS232/ 1RS485-module

Process input data

Process input data is data from the connected field device that is transmitted via the BLxx-1RSxxx-module to the PLC. The BLxx-1RSxxx-module sends the data, received by the device, into a 128-byte receive-buffer. The module then transmits the data segmented via the module bus and the gateway to the PLC.

The transmission is realized in a 8-byte format which is structured as follows:

- 1 status byte is required to ensure trouble-free transmission of the data.
- 1 byte contains the diagnostics data.
- 6 bytes are used to contain the user data.

Figure 13-1:
Process input
data of
RSxxx modules

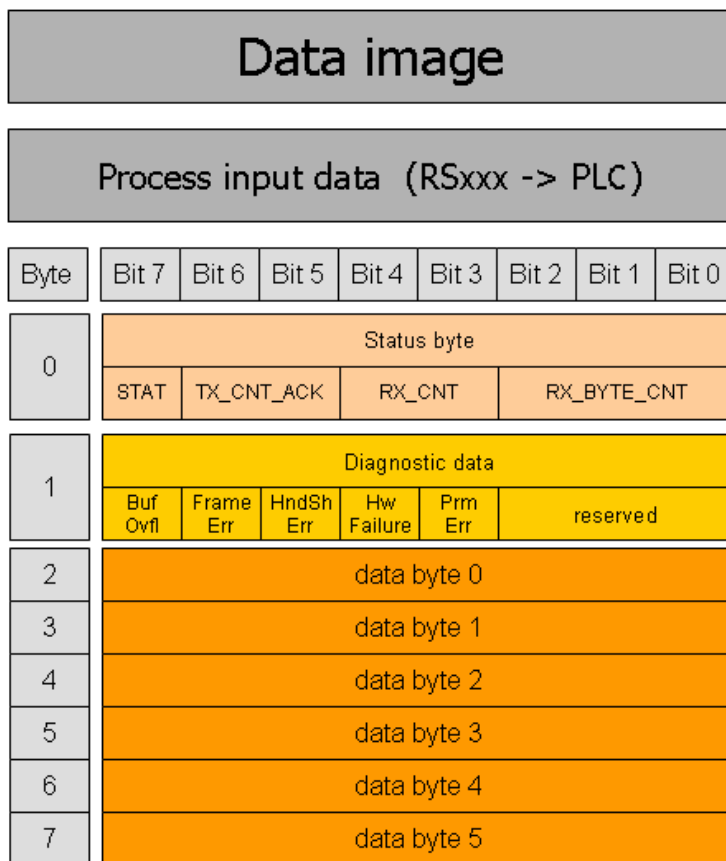

<i>Table 13-1: Meaning of the data bits (process input)</i>	Designation	Value	Description
	BufOvfl; FrameErr; HndShErr; HwFailure; PrmErr	0 - 255	Diagnostic information (correspond to the diagnostic information in the diagnosis telegram). These diagnostics are always displayed and independent to the setting of the parameter „Diagnostics“.
	STAT	0-1	1: The communication with the data terminal equipment (DTE) is not disturbed. 0: The communication with the data terminal equipment (DTE) is disturbed. A diagnosis message is generated if the parameter "Diagnostics" is set to "0" = release. The diagnostic data show the cause of the communication disturbance. The user has to set back this bit in the process output data by using STATRES.
	TX_CNT_ACK	0-3	The value TX_CNT_ACK is a copy of the value TX_CNT. The value TX_CNT was transferred together with the last data segment of the process output data. The value TX_CNT_ACK is a confirmation of successful acceptance of the data segment using TX_CNT.
	RX_CNT	0-3	This value is transferred together with every data segment. The RX_CNT values are sequential: The RX_CNT values are sequential: 00->01->10->11->00... (decimal: 0->1->2->3->0...) Errors in this sequence show the loss of data segments.
	RX_BYTE_CNT	0-7	Number of the valid bytes in this data segment.

Process output data

Process output data are data which are sent from the PLC via the gateway and the BLxx-1RSxxx-module to a connected field device.

The data received from the PLC are loaded into the 64-bit transmit-buffer in the BLxx-1RSxxx-module.

The transmission is realized in a 8-byte format which is structured as follows:

- 1 control byte is required to ensure trouble-free transmission of the data.
- 1 byte contains, signals to start the flushing of transmit- and receive buffer.
- 6 bytes are used to contain the user data.

Figure 13-2:
Process output
data of RSxxx-
modules

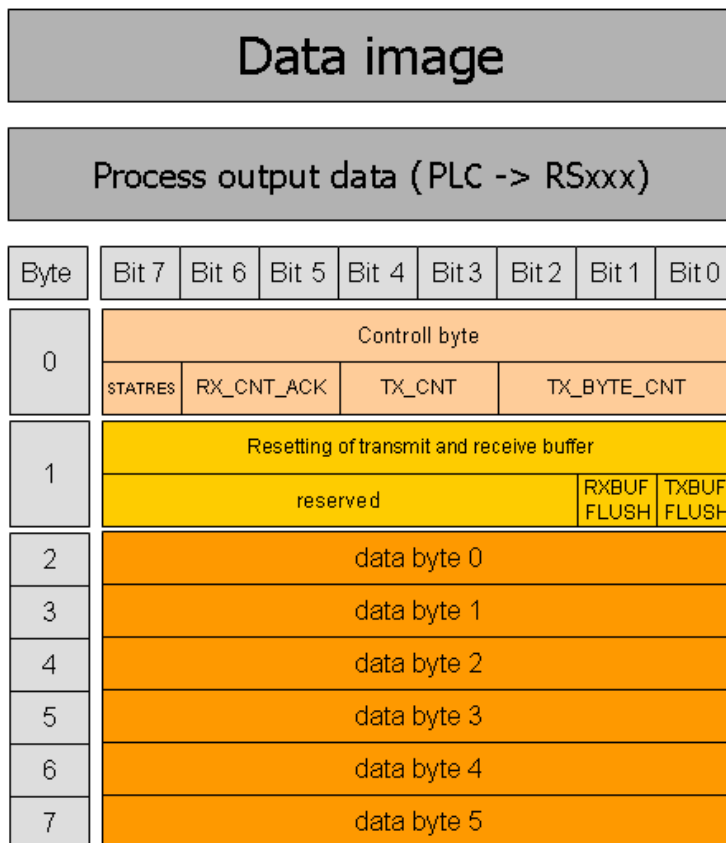

Table 13-2:
Meaning of the
data bits
(process output)

Designation	Value	Description
STATRES	0-1	This bit is set to reset the STAT bit in the process input data. With the change from 1 to 0 the STAT bit is reset (from 0 to 1). If this bit is 0, all changes in TX_BYTE_CNT, TX_CNT and RX_CNT_ACK are ignored. The clearing of the receive and transmit buffer by RXBUF FLUSH/TXBUF FLUSH is possible. The value 1 or the transition from 0 to 1 disables the clearing of the receive and transmit buffer by the RXBUF FLUSH/TXBUF FLUSH.

Table 13-2:
Meaning of the
data bits
(process output)

Designation	Value	Description
RXBUF FLUSH	0 - 1	The RXBUF FLUSH bit is used for clearing the receive buffer. If STATRES = 1: A request with RXBUF FLUSH = 1 will be ignored. If STATRES = 0: RXBUF FLUSH = 1 will clear the receive buffer.
TXBUF FLUSH	0-1	The TXBUF FLUSH bit is used for clearing the transmit buffer. If STATRES = 1: A request with TXBUF FLUSH = 1 will be ignored. If STATRES = 0: TXBUF FLUSH = 1 will clear the receive buffer.
RX_CNT_ACK	0-3	The value RX_CNT_ACK is a copy of the value RX_CNT. The value TX_CNT was transferred together with the last data segment of the process output data. RX_CNT_ACK has to be set analog to RX_CNT (in the status byte). RX_CNT_ACK is an acknowledge for the successful transmission of the data segment with RX_CNT. New data can now be received.
TX_CNT	0-3	This value is transferred together with every data segment. The TX_CNT values are sequential: The TX_CNT values are sequential: 00->01->10->11->00... (decimal: 0->1->2->3->0...) Errors in this sequence show the loss of data segments.
TX_BYTE_CNT	0 - 7	Number of the valid bytes in this data segment.

13.1.2 SSI module

Process input data

The field input data is transferred from the connected field device to BL20-1SSI-module.

The process input data is the data that is transferred by the BL20-1SSI-module via a gateway to the PLC.

The transmission is realized in a 8-byte format which is structured as follows:

- 4 bytes are used for representing the data that was read from the register with the address stated at REG_RD_ADR.
- When necessary, 1 byte represents the register address of the read data and an acknowledgement that the read operation was successful.
- 1 byte can be used to transfer status messages of the SSI encoder. This byte also contains an acknowledgement that the write operation to the register was successful and indication of an active write operation.
- 1 byte contains the results of comparison operations with the SSI encoder value.
- 1 byte contains messages concerning the communication status between the BL20-1SSI module and the SSI encoder, as well as other results of comparison operations.

The following table describes the structure of the 8 x 8 bits of the process input data.

STS (or ERR) contains non-retentive status information, i.e. the bit concerned indicates the actual status.

FLAG describes a retentive flag that is set in the event of a particular event. The bit concerned retains the value until it is reset.

Figure 13-3:
Process input
data of the SSI-
module

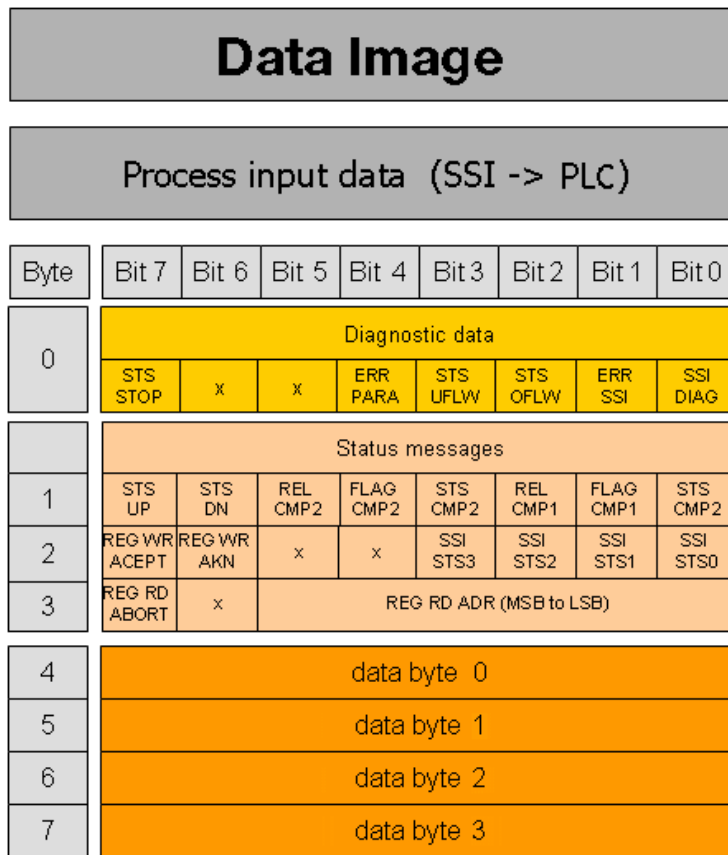

Meaning of the data bits (process input)

Table 13-3:
Meaning of the
data bits
(process input)

Designation	Value	Description
REG_RD_DATA	0... 2 ³² -1	Content of the register to be read if REG_RD_ABORT=0. If REG_RD_ABORT =1, then REG_RD_DATA=0.
REG_RD_ABORT	0	The reading of the register defined in REG_RD_ADR has been accepted and executed. The content of the register can be found in the user data (REG_RD_DATA, byte 0-3).
	1	Reading of the register defined in REG_RD_ADR has not been accepted. The user data range (REG_RD_DATA Bytes 0-3) is zero.
REG_RD_ADR	0...63	Address of the register to be read. If the read operation is successful (REG_RD_ABORT = 0), the user data is located in REG_RD_DATA of the process input data (bytes 0 to 3).
REG_WR_ACCEPT	0	Writing the user data from the process output to the register addressed with REG_WR_ADR in the process output could not be done.
	1	Writing the user data from the process output to the register addressed with REG_WR_ADR in the process output was successful.

Table 13-3:
Meaning of the
data bits
(process input)

Designation	Value	Description
REG_WR_AKN	0	No modification of the data in the register bank by process output, i.e. REG_WR = 0. A write job would be accepted with the next telegram of process output data. (handshake for data transmission to the register.)
	1	A modification of the register contents by a process output was initiated, which means REG_WR = 1. A write job would not be accepted with the next telegram of process output data.
SSI_STS3	0	These four bits transfer the status bits of the SSI encoder with the status messages of the SSI module. With some SSI encoders, the status bits are transferred together with the position value.
	1	
SSI_STS2	0	
	1	
SSI_STS1	0	
	1	
SSI_STS0	0	
	1	
STS_UP (LED UP)	0	The SSI encoder values are decremented or the values are constant.
	1	The SSI encoder values are incremented.
STS_DN (LED DN)	0	The SSI encoder values are incremented or the values are constant.
	1	The SSI encoder values are decremented.
REL_CMP2	0	A comparison of the register contents has produced the following result: (REG_SSI_POS) < (REG_CMP2)
	1	A comparison of the register contents has produced the following result: (REG_SSI_POS) ≥ (REG_CMP2)
FLAG_CMP2	0	Default status, i.e. the register contents have not yet matched (REG_SSI_POS) = (REG_CMP2) since the last reset.
	1	The contents of the registers match (REG_SSI_POS) = (REG_CMP2). This marker must be reset with CLR_CMP1 = 1 in the process output data.

Table 13-3:
Meaning of the
data bits
(process input)

Designation	Value	Description
STS_CMP2	0	A comparison of the register contents has produced the following result: (REG_SSI_POS) \neq (REG_CMP1)
	1	A comparison of the register contents has produced the following result: (REG_SSI_POS) = (REG_CMP2)
REL_CMP1	0	A comparison of the register contents has produced the following result: (REG_SSI_POS) < (REG_CMP1)
	1	A comparison of the register contents has produced the following result: (REG_SSI_POS) \geq (REG_CMP1)
FLAG_CMP1	0	Default status, i.e. the register contents have not yet matched (REG_SSI_POS) = (REG_CMP1) since the last reset.
	1	The contents of the registers match (REG_SSI_POS) = (REG_CMP1). This marker must be reset with CLR_CMP1 = 1 in the process output data.
STS_CMP1	0	A comparison of the register contents has produced the following result: (REG_SSI_POS) \neq (REG_CMP1)
	1	A comparison of the register contents has produced the following result: (REG_SSI_POS) = (REG_CMP1)
STS_STOP	0	The SSI encoder is read cyclically.
	1	Communication with the SSI encoder is stopped as STOP = 1 (process output) or ERR_PARA = 1.
ERR_PARA	0	The parameter set of the module has been accepted.
	1	Operation of the module is not possible with the present parameter set.
STS_UFLW	0	A comparison of the register contents has produced the following result: (REG_SSI_POS) \geq (REG_LOWER_LIMIT)
	1	A comparison of the register contents has produced the following result: (REG_SSI_POS) < (REG_LOWER_LIMIT)
STS_OFLW	0	A comparison of the register contents has produced the following result: (REG_SSI_POS) \leq (REG_UPPER_LIMIT)
	1	A comparison of the register contents has produced the following result: (REG_SSI_POS) > (REG_UPPER_LIMIT)

*Table 13-3:
Meaning of the
data bits
(process input)*

Designation	Value	Description
ERR_SSI	0	SSI encoder signal present.
	1	SSI encoder signal faulty. (e.g. due to a cable break).
SSI_DIAG	0	No enabled status signal is active (SSI_STSx = 0).
	1	At least one enabled status signal is active (SSI_STSx = 1)

Process output data

Field output data is output from an BL20-1SSI-module to a field device.

The process output data is the data that is transferred by the PLC via a gateway to the BL20-1SSI module.

The transmission is realized in a 8-byte format which is structured as follows:

- 1 byte contains a Stop bit for interrupting communication with the encoder.
- 1 byte is used for controlling the comparison operations.
- 1 byte contains the register address of the data to be written to bytes 0 to 3 of this telegram and a write request.
- 1 byte contains the register address for the data that is to be read with the next response telegram.
- 4 bytes are used for representing the data that is to be written to the register with the address specified at REG_WR_DATA.

Figure 13-4:
Process output
data of the SSI-
module

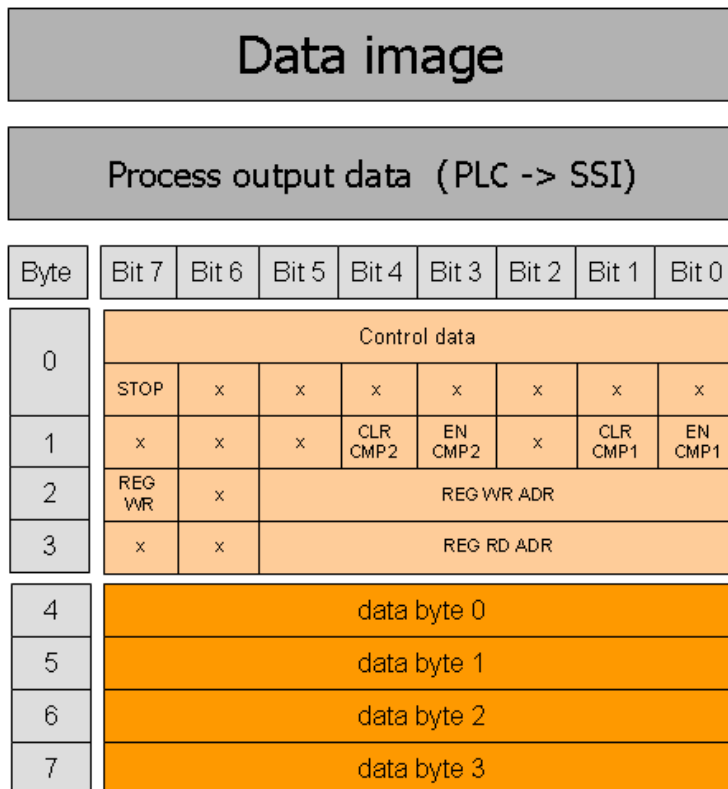

Meaning of the data bits (process output)

Table 13-4:
Meaning of the
data bits
(process output)

Designation	Value	Description
REG_WR_DATA	0... $2^{32}-1$	Value which has to be written to the register with the address REG_WR_ADR.
REG_RD_ADR	0...63	Address of the register which has to be read. If the reading was successful (REG_RD_ABORT = 0), the user data can be found in REG_RD_DATA in the status interface (bytes 4-7).
REG_WR	0	Default status, i.e. there is no request to overwrite the content of the register with the address stated at REG_WR_ADR with REG_WR_DATA. Bit REG_WR_AKN is reset (0) if necessary.
	1	Request to overwrite the content of the register with address REG_WR_ADR with REG_WR_DATA.
REG_WR_ADR	0...63	Address of the register, which has to be written with REG_WR_DATA.
CLR_CMP2	0	Default status, i.e. no reset of FLAG_CMP2 active.
	1	Reset of FLAG_CMP2 active.
EN_CMP2	0	Default status, i.e. the data bits REL_CMP2, STS_CMP2 and FLAG_CMP2 always have the value 0, irrespective of the actual SSI encoder value.
	1	Comparison active, i.e. the data bits REL_CMP2, STS_CMP2 and FLAG_CMP2 always have a value based on the result of the comparison with the SSI encoder value.
CLR_CMP1	0	Default status, i.e. reset of FLAG_CMP1 not active.
	1	Reset of FLAG_CMP1 active.
EN_CMP1	0	Default status, i.e. the data bits REL_CMP1, STS_CMP1 and FLAG_CMP1 always have the value 0, irrespective of the actual SSI encoder value.
	1	Comparison active, i.e. the data bits REL_CMP1, STS_CMP1 and FLAG_CMP1 always have a value based on the result of the comparison with the SSI encoder value.
STOP	0	Request to read the SSI encoder cyclically
	1	Request to interrupt communication with the encoder

13.1.3 SWIRE-module

SWIRE in Modbus

In Modbus, the process data of SWIRE-modules are mapped to the data area for digital In- and output modules **not** to the data area for intelligen modules (see [chapter 6.3, page 6-7 ff.](#))

Process input data

Byte	Bit 7	Bit 6	Bit 5	Bit 4	Bit 3	Bit 2	Bit 1	Bit 0
n -1	(Data from modules to the left)							
n	SWIRE Slave 2				SWIRE Slave 1			
	SD2		PKZ-ST2	SI2	SD1		PKZ-ST1	SI1
n +1	SWIRE Slave 4				SWIRE Slave 3			
	SD4		PKZ-ST4	SI4	SD3		PKZ-ST3	SI3
n +2	SWIRE Slave 6				SWIRE Slave 5			
	SD6		PKZ-ST6	SI6	SD5		PKZ-ST5	SI5
n +3	SWIRE Slave 8				SWIRE Slave 7			
	SD8		PKZ-ST8	SI8	SD7		PKZ-ST7	SI7
n +4	SWIRE Slave 10				SWIRE Slave 9			
	SD10		PKZ-ST10	SI10	SD9		PKZ-ST9	SI9
n +5	SWIRE Slave 12				SWIRE Slave 11			
	SD12		PKZ-ST12	SI12	SD11		PKZ-ST11	SI11
n +6	SWIRE Slave 14				SWIRE Slave 13			
	SD14		PKZ-ST14	SI14	SD13		PKZ-ST13	SI13
n +7	SWIRE Slave 16				SWIRE Slave 15			
	SD16		PKZ-ST16	SI16	SD15		PKZ-ST15	SI15
n+8 ff.	(Data from modules to the right)							

Table 13-5:
Data bits

Design.	Status	Comment
Slx		Switch status, relay x
		Slx supplies the switch status of the contactor coil of the SWIRE bus slave as a feedback signal. Slx makes it possible to check whether the set switch status was executed by a mechanical connection. This must take into account the time delay between the setting of an output, a mechanical execution and the subsequent feedback signal.
0	off Off	Contactor coil is switched off
1	on On	Contactor coil is switched on

Table 13-5:
Data bits

Design.	Status	Comment
PKZSTx		Switch status, PKZ x
0	off Off	The motor-protective circuit breaker is off or has tripped
1	on On	The motor-protective circuit breaker is switched on
SCx		Communication error, slave x
		Setting the parameter $SC_{DIAG}Sx$ sets the SCx-bit in the process input data. The information is provided as status information in the PLC for the user.
0	ON ON LINE LINE	Status of slave x:
1	OFF OFF LINE LINE	Status of slave x: diagnostics available

Process output data

Byte	Bit 7	Bit 6	Bit 5	Bit 4	Bit 3	Bit 2	Bit 1	Bit 0
n - 1	(Data from modules to the left)							
n	SWIRE Slave 2				SWIRE Slave 1			
				SO2				SO1
n + 1	SWIRE Slave 4				SWIRE Slave 3			
				SO4				SO3
n + 2	SWIRE Slave 6				SWIRE Slave 5			
				SO6				SO5
n + 3	SWIRE Slave 8				SWIRE Slave 7			
				SO8				SO7
n + 4	SWIRE Slave 10				SWIRE Slave 9			
				SO10				SO9
n + 5	SWIRE Slave 12				SWIRE Slave 11			
				SO12				SO11
n + 6	SWIRE Slave 14				SWIRE Slave 13			
				SO14				SO13
n + 7	SWIRE Slave 16				SWIRE Slave 15			
				SO16				SO15
n + 8 ff.	(Data from modules to the right)							

Table 13-6:
Data bits

Design.	Status	Comment
SOx		relay x
		SOx is transferred as the switch status of the contactor coil from the SWIRE bus master to the appropriate SWIRE bus slave.
0	off	Off
1	on	On

13.1.4 Encoder/PWM-module BL20-E-2CNT-2PWM

Detailed information about the process image of the module can be found in separate manual, [D301224](#), „BL20 – I/O-MODULES BL20-E-2CNT-2PWM“, chapter 2)

13.1.5 RFID-module BL20-2RFID-S/ -A

BL20-2RFID-S and BL20-2RFID-A (see RFID-documentation under www.turck.de)

13.2 Changing the IP address of a PC/ network interface card

13.2.1 Changing the IP address in Windows

The IP address is changed in the Control Panel:

- in Windows 2000/Windows XP under "Network Connections",
- in Windows 7 under "Network and Sharing Center".

Figure 13-5:
Changing the IP
address in
Windows 2000/
XP

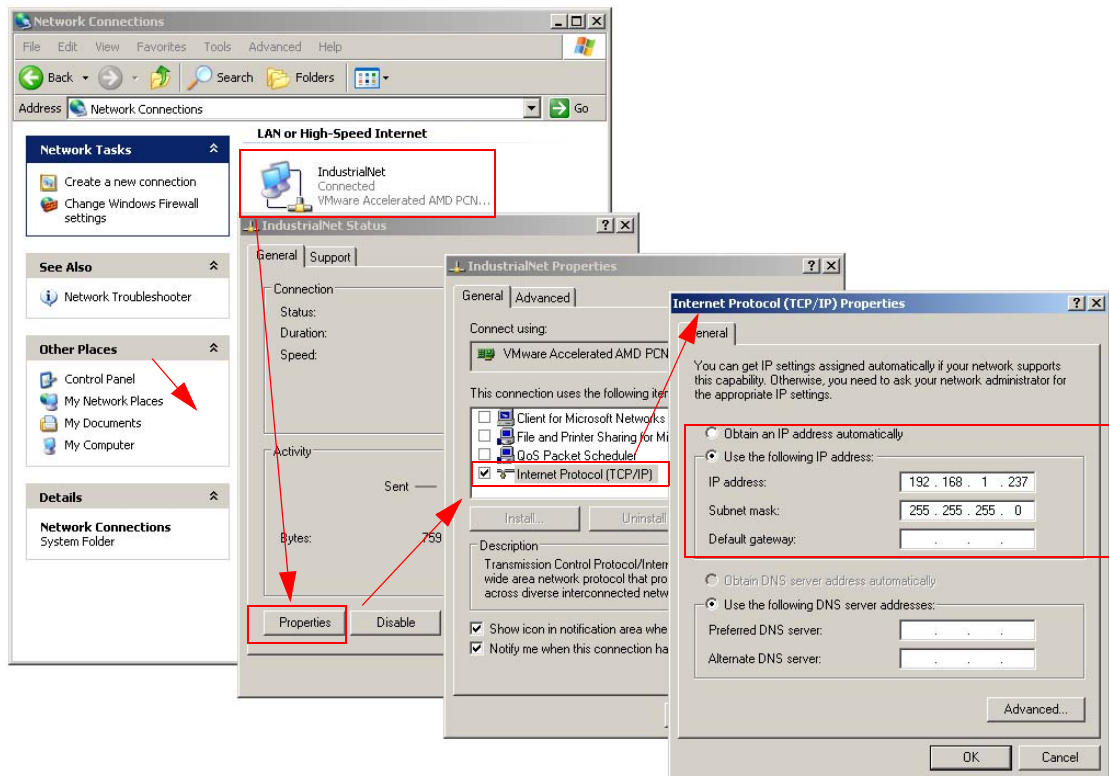
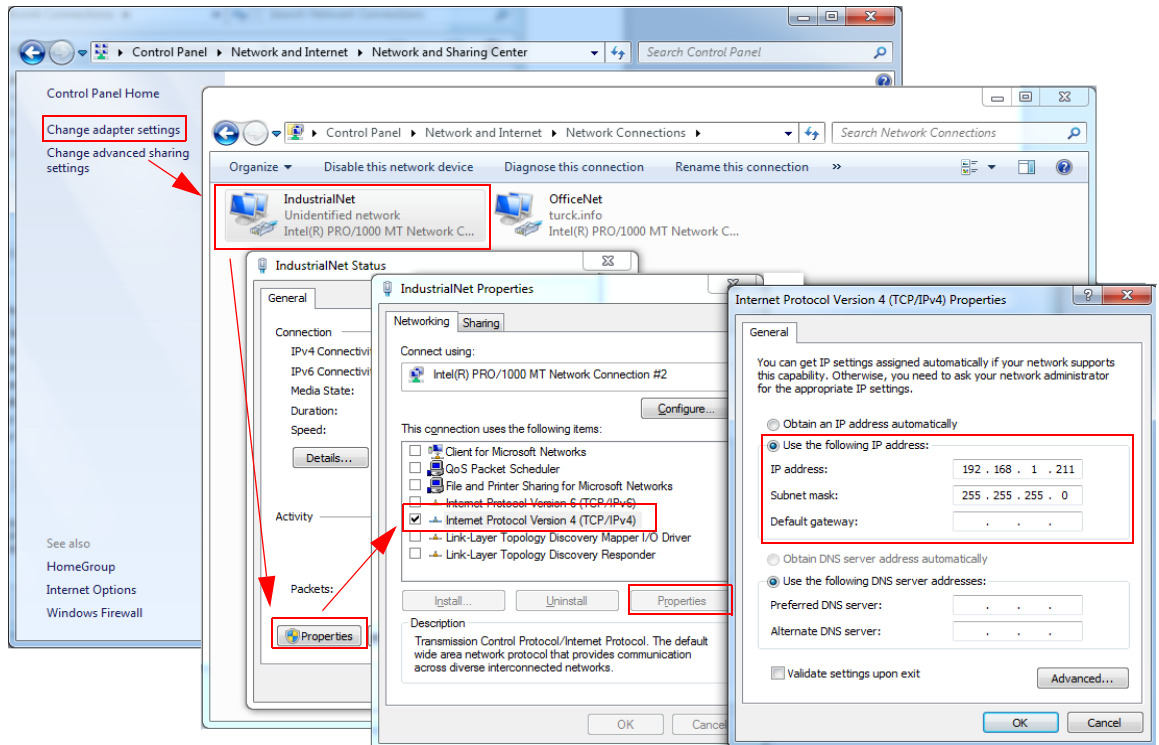

Figure 13-6:
Changing the IP
address in
Windows 7



13.2.2 Changing the IP address via I/O-ASSISTANT V3

The Busaddress Management DTM in the software I/O-ASSISTANT (access via: "Additional functions → Busaddress Management") offers the possibility to browse the whole Ethernet network for connected nodes and to change their IP address as well as the subnet mask according to the application (see also).

Further information about this issue can be found under [Adressierung über I/O-ASSISTANT 3 \(FDT/DTM\) \(page 4-12\)](#).

Figure 13-7:
Busaddress
Management

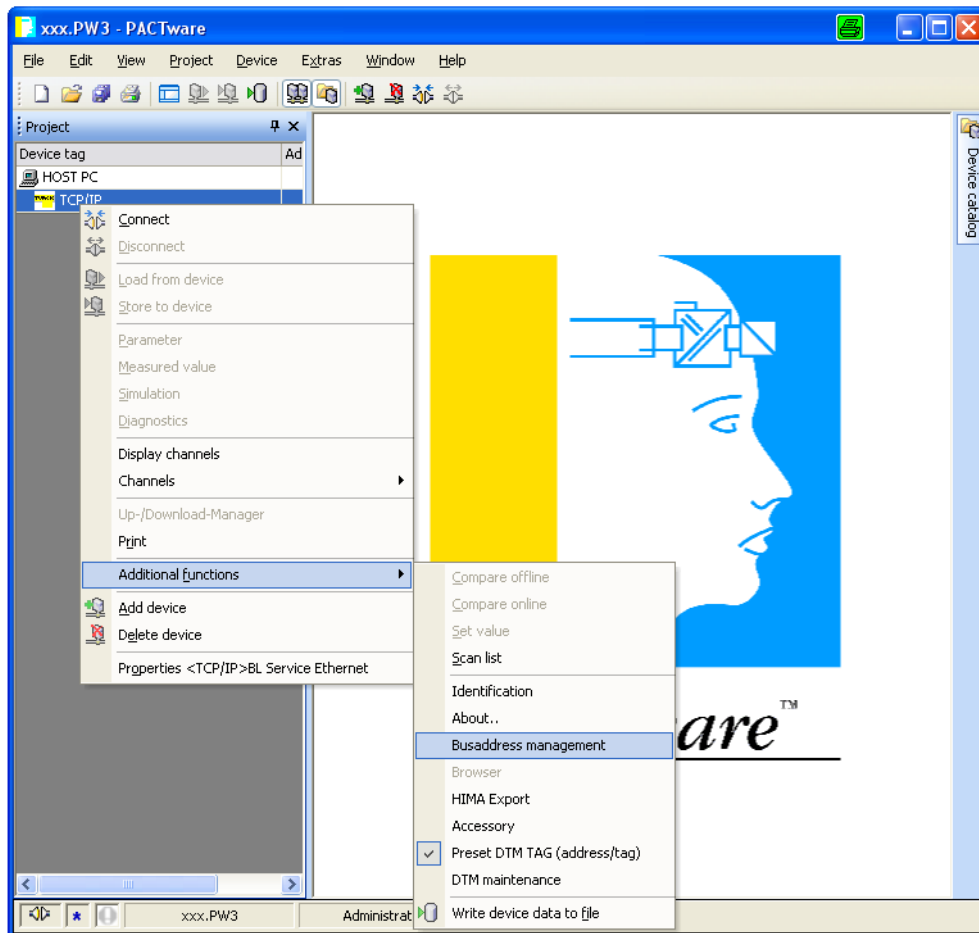

13.3 Deactivating/ adapting the firewall in Windows

When using the Windows Firewall, problems may occur while changing IP addresses via the I/O-ASSISTANT. In this case, you can deactivate the system integrated Windows firewall completely or adapt it to your application.

- **Deactivating the Windows firewall**

Open the "Windows Firewall" dialog in the control panel of your PC and deactivate it as follows:

Figure 13-8:
Deactivating
the Firewall in
Windows 2000/
XP

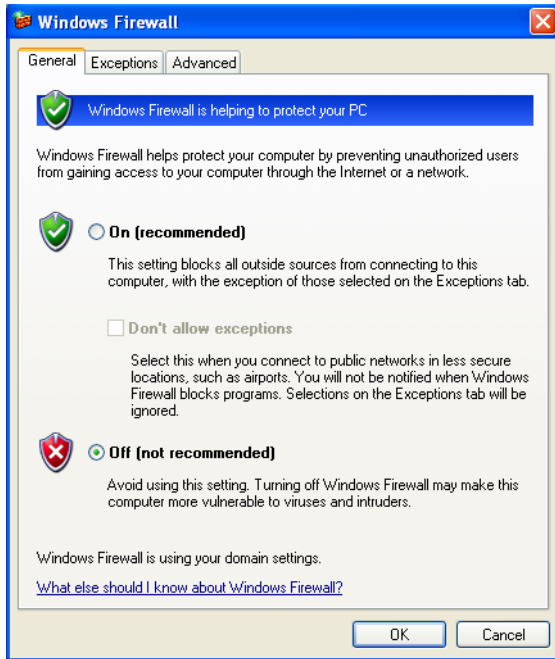
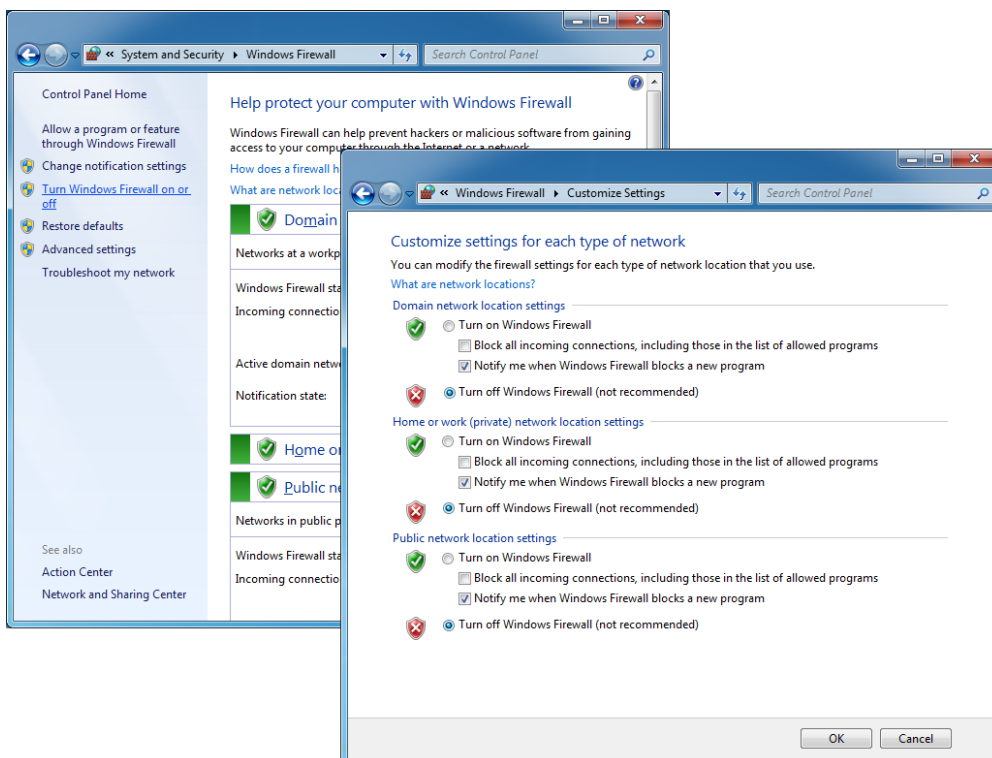

Figure 13-9:
Deactivating
the Firewall in
Windows 7



■ **Adapting the Windows firewall**

The firewall remains active, the option "Don't allow exceptions" it deactivated:

Figure 13-10:
Adapting the
Firewall in Win-
dows 2000/ XP

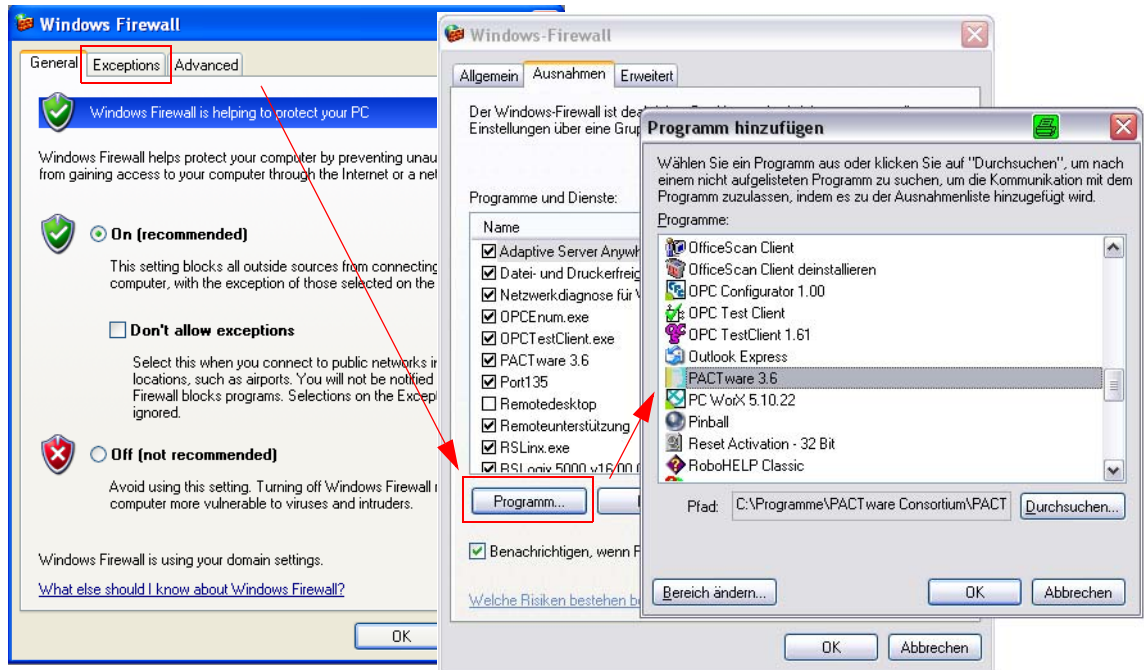
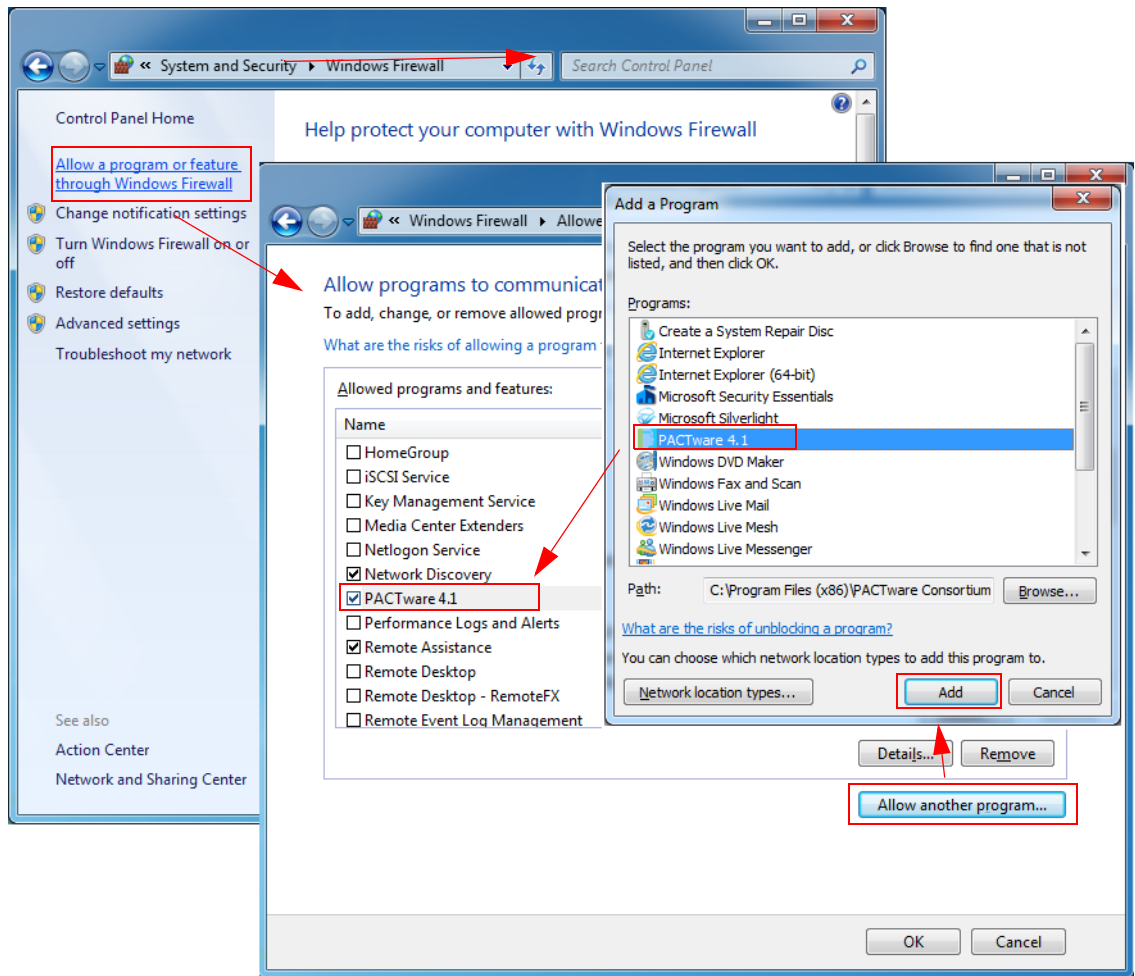

Figure 13-11:
Adapting the
Firewall in Win-
dows 7



13.4 Addressing via DHCP

In this application example, the IP address is set via DHCP using the software tool "BootP/DHCP-Server" version 2.3.2.0 from Rockwell Automation.

Figure 13-12: BootP-Server from Rockwell Automation

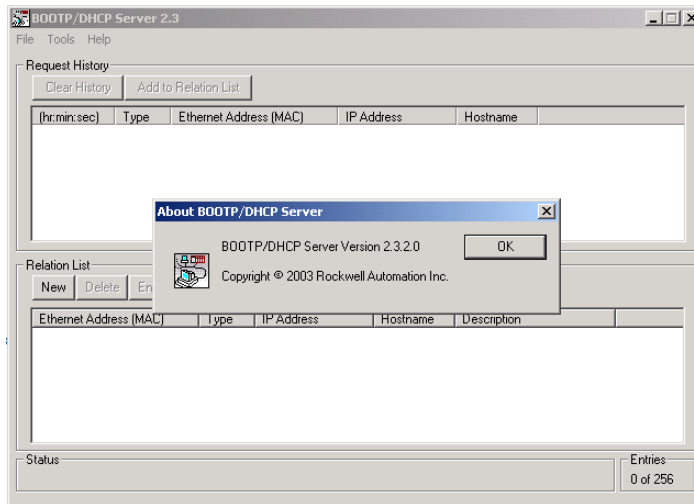

Addresses in the range from 1 to 254 can be allocated. The addresses 0 and 255 are reserved for broadcast messages in the subnet.



Hinweis

The rotary coding switches on the gateway must be set to "300" = BootP, "400" = DHCP or "600" = PGM-DHCP in order to enable the BootP/DHCP-Mode. (see also [chapter 3](#), section [Adressierung \(page 3-9\)](#)).

After having been connected to the network, the BL20 sends DHCP requests to the server using its MAC-ID.

Figure 13-13: DHCP-request of the device

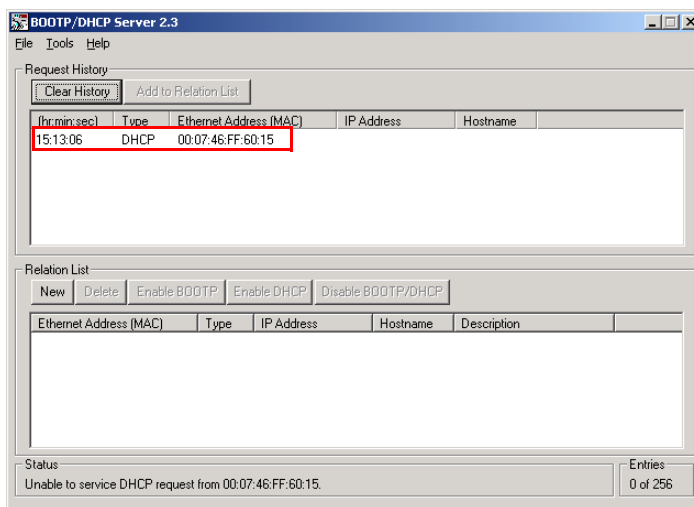

A double click on the request-entry opens the "New Entry" dialog box in which an IP address can be assigned to the s MAC-ID.

Figure 13-14:
Setting the IP
address via
DHCP

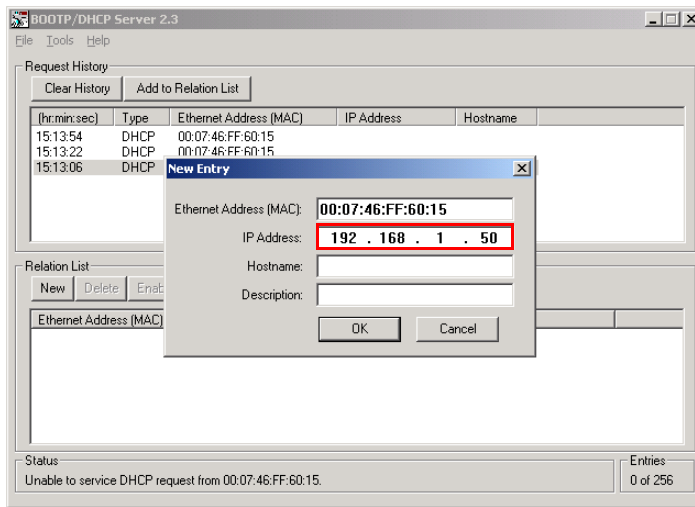

The BootP/DHCP-Server sends the IP Address via BootP/DHCP to the device and, after a few seconds, the stations answers with its new IP address when having stored it.

Figure 13-15:
Set IP address

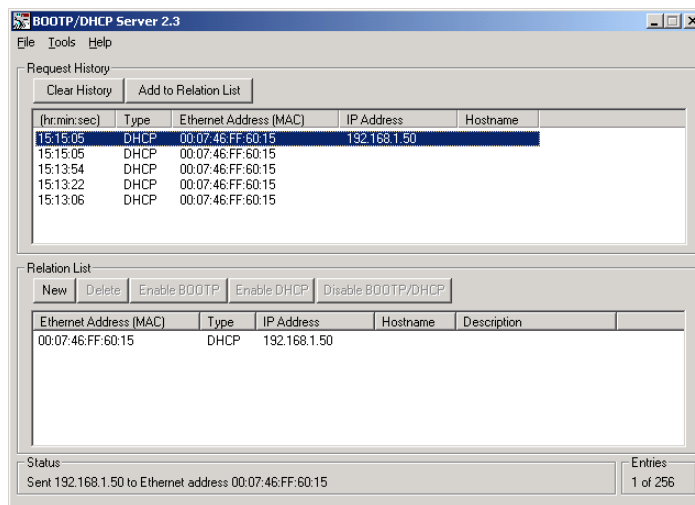

Achtung

The device loses its IP-address in case of a power-reset, if the BootP/DHCP-server is shut down.

13.5 Ident codes the BL20-modules

Each module is identified by the gateway using a unique identifier.

<i>Table 13-7: Module ident codes</i>	Module	ident code
	<i>Digital input modules</i>	
	BL20-2DI-24VDC-P	0x210020xx
	BL20-2DI-24VDC-N	0x220020xx
	BL20-2DI-120/230VAC	0x230020xx
	BL20-4DI-24VDC-P	0x410030xx
	BL20-4DI-24VDC-N	0x420030xx
	BL20-4DI-NAMUR	0x015640xx
	BL20-E-8DI-24VDC-P	0x610040xx
	BL20-16DI-24VDC-P	0x810050xx
	BL20-E-16DI-24VDC-P	0x820050xx
	BL20-32DI-24VDC-P	0xA10070xx
	<i>Analog input modules</i>	
	BL20-1AI-I(0/4...20MA)	0x012350xx
	BL20-2AI-I(0/4...20MA)	0x225570xx
	BL20-1AI-U(-10/0...+10VDC)	0x011350xx
	BL20-2AI-U(-10/0...+10VDC)	0x235570xx
	BL20-2AI-PT/NI-2/3	0x215770xx
	BL20-2AI-THERMO-PI	0x215570xx
	BL20-2AIH-I	0x2179C0xx
	BL20-4AI-U/I	0x417790xx
	BL20-E-4AI-TC	0x427790xx
	BL20-E-8AI-U/I-4AI-PT/NI	0x6199B0xx
	<i>Digital output modules</i>	
	BL20-2DO-24VDC-0,5A-P	0x212002xx
	BL20-2DO-24VDC-0,5A-N	0x222002xx
	BL20-2DO-24VDC-2A-P	0x232002xx
	BL20-2DO-120/230VAC-0.5A	0x250002xx
	BL20-4DO-24VDC-0,5A-P	0x013003xx
	BL20-E-8DO-24VDC-0.5A-P	0x610004xx

Table 13-7:
Module
ident codes

Module	ident code
BL20-16DO-24VDC-0,5A-P	0x413005xx
BL20-E-16DO-24VDC-0.5A-P	0x820005xx
BL20-32DO-24VDC-0,5A-P	0x614007xx
<i>Analog output modules</i>	
BL20-1AO-I(0/4...20MA)	0x010605xx
BL20-2AO-I(0/4...20MA)	0x220807xx
BL20-2AO-U(-10/0...+10VDC)	0x210807xx
BL20-2AO-H	0x217AB7xx
BL20-E-4AO-U/I	0x417A09xx
<i>Relay modules</i>	
BL20-2DO-R-NC	0x230002xx
BL20-2DO-R-NO	0x220002xx
BL20-2DO-R-CO	0x210002xx
<i>technology modules</i>	
BL20-1RS232	0x014799xx
BL20-1RS485/422	0x024799xx
BL20-1SSI	0x044799xx
BL20-E-1SWIRE	0x169C99xx
BL20-E-2CNT-2PWM	0x017BCCxx
BL20-2RFID-A	0x017977xx
BL20-2RFID-S	0x2179CCxx
<i>Power distribution modules</i>	
BL20-BR-24VDC-D	0x013000xx
BL20-BR-24VDC-RED	0x440030xx
BL20-PF-24VDC-D	0x023000xx
BL20-PF-120/230VAC-D	0x053000xx

14 Glossary

A

Acknowledge

Acknowledgment of a signal received.

Active metal component

Conductor or conducting component that is electrically live during operation.

Address

Identification number of, e.g. a memory position, a system or a module within a network.

Addressing

Allocation or setting of an address, e. g. for a module in a network.

ARP

Used to definitely allocate the hardware addresses (MAC-IDs) assigned worldwide to the IP addresses of the network clients via internal tables.

Analog

Infinitely variable value, e. g. voltage. The value of an analog signal can take on any value, within certain limits.

Automation device

A device connected to a technical process with inputs and outputs for control. Programmable logic controllers (PLC) are a special group of automation devices.

B

Baud

Baud is a measure for the transmission speed of data. 1 Baud corresponds to the transmission of one bit per second (bit/s).

Baud rate

Unit of measurement for measuring data transmission speeds in bit/s.

Bidirectional

Working in both directions.

Bonding strap

Flexible conductor, normally braided, that joins inactive components, e. g. the door of a switchgear cabinet to the cabinet main body.

Bus

Bus system for data exchange, e. g. between CPU, memory and I/O levels. A bus can consist of several parallel cables for data transmission, addressing, control and power supply.

Bus cycle time

Time required for a master to serve all slaves or stations in a bus system, i.e. reading inputs and writing outputs.

Bus line

Smallest unit connected to a bus, consisting of a PLC, a coupling element for modules on the bus and a module.

Bus system

All units which communicate with one another via a bus.

C

Capacitive coupling

Electrical capacitive couplings occur between cables with different potentials. Typical sources of interference are, for example, parallel-routed signal cables, contactors and electrostatic discharges.

Check-back interface

The check-back interface is the interface from the counter module to the internal module bus. The bits and bytes are converted by the gateway from the respective type of communication applicable to the fieldbus in to the module-specific bits and bytes.

Coding elements

Two-piece element for the unambiguous assignment of electronic and base modules.

Configuration

Systematic arrangement of the I/O-modules of a station.

Control interface

The control interface is the interface from the internal module bus to the counter module. The commands and signals directed to the counter module are converted by the gateway from the respective type of communication applicable to the fieldbus in to the module-specific bits and bytes.

CPU

Central Processing Unit. Central unit for electronic data processing, the processing core of the PC.

D

DHCP

Client-Server-protocol which reduces the effort of assigning IP addresses or other parameters. Serves for dynamic and automatic configuration of devices.

Digital

A value (e. g. a voltage) which can adopt only certain statuses within a finite set, mostly defined as 0 and 1.

DIN

German acronym for German Industrial Standard.

E

EIA

Electronic Industries Association – association of electrical companies in the United States.

Electrical components

All objects that produce, convert, transmit, distribute or utilize electrical power (e. g. conductors, cable, machines, control devices).

EMC

Electromagnetic compatibility – the ability of an electrical part to operate in a specific environment without fault and without exerting a negative influence on its environment.

EN

German acronym for European Standard.

ESD

Electrostatic Discharge.

F**Field power supply**

Voltage supply for devices in the field as well as the signal voltage.

Fieldbus

Data network on sensor/actuator level. A fieldbus connects the equipment on the field level. Characteristics of a fieldbus are a high transmission security and real-time behavior.

Force Mode

Software mode which enables the user to set his plant to a required state by forcing certain variables on the input and output modules.

G**GND**

Abbreviation of ground (potential "0").

Ground

Expression used in electrical engineering to describe an area whose electrical potential is equal to zero at any given point. In neutral grounding devices, the potential is not necessarily zero, and one speaks of the ground reference.

Ground connection

One or more components that have a good and direct contact to earth.

Ground reference

Potential of ground in a neutral grounding device. Unlike earth whose potential is always zero, it may have a potential other than zero.

H**Hexadecimal**

System of representing numbers in base 16 with the digits 0... 9, and further with the letters A, B, C, D, E and F.

Hysteresis

A sensor can get caught up at a certain point, and then "waver" at this position. This condition results in the counter content fluctuating around a given value. Should a reference value be within this fluctuating range, then the relevant output would be turned on and off in rhythm with the fluctuating signal.

I**I/O**

Input/output.

Impedance

Total effective resistance that a component or circuit has for an alternating current at a specific frequency.

Inactive metal components

Conductive components that cannot be touched and are electrically isolated from active metal components by insulation, but can adopt voltage in the event of a fault.

Inductive coupling

Magnetic inductive couplings occur between two cables through which an electrical current is flowing. The magnetic effect caused by the electrical currents induces an interference voltage. Typical sources of interference are for example, transformers, motors, parallel-routed network and HF signal cables.

Intelligent modules

Intelligent modules are modules with an internal memory, able to transmit certain commands (e. g. substitute values and others).

IP

Abbreviation for Internet-Protocol, protocol for the packet-oriented and connectionless transport of data packets from a transmitter to a receiver crossing different networks.

L

Lightning protection

All measures taken to protect a system from damage due to overvoltages caused by lightning strike.

Low impedance connection

Connection with a low AC impedance.

LSB

Least Significant bit

M

Mass

All interconnected inactive components that do not take on a dangerous touch potential in the case of a fault.

Master

Station in a bus system that controls the communication between the other stations.

Modbus TCP

The Modbus protocol is part of the TCP/IP protocol.

The communication is realized via function codes, which are implemented into the data telegram. Modbus TCP uses the Transmission Control Protocol (TCP) for the transmission of the Modbus user protocol in Ethernet-TCP-IP networks.

Module bus

The module bus is the internal bus in a station. The modules communicate with the gateway via the module bus which is independent of the fieldbus.

MSB

Most Significant bit

P

Ping

Implementation of an echo-protocol, used for testing whether a particular host is operating properly and is reachable on the network from the testing host.

PLC

Programmable Logic Controller.

Potential compensation

The alignment of electrical levels of electrical components and external conductive components by means of an electrical connection.

Potential free

Galvanic isolation of the reference potentials in I/O-modules of the control and load circuits.

Potential linked

Electrical connection of the reference potentials in I/O-modules of the control and load circuits.

Protective earth

Electrical conductor for protection against dangerous shock currents. Generally represented by PE (protective earth).

R**Radiation coupling**

A radiation coupling appears when an electromagnetic wave hits a conductive structure. Voltages and currents are induced by the collision. Typical sources of interference are for example, sparking gaps (spark plugs, commutators from electric motors) and transmitters (e. g. radio), that are operated near to conducting structures.

Reaction time

The time required in a bus system between a reading operation being sent and the receipt of an answer. It is the time required by an input module to change a signal at its input until the signal is sent to the bus system.

Reference potential

Potential from which all voltages of connected circuits are viewed and/or measured.

Repeater

Amplifier for signals transmitted via a bus.

Root-connecting

Creating a new potential group using a power distribution module. This allows sensors and loads to be supplied individually.

RS 485

Serial interface in accordance with EIA standards, for fast data transmission via multiple transmitters.

S**Serial**

Type of information transmission, by which data is transmitted bit by bit via a cable.

Setting parameters

Setting parameters of individual stations on the bus and their modules in the configuration software of the master.

Shield

Conductive screen of cables, enclosures and cabinets.

Shielding

Description of all measures and devices used to join installation components to the shield.

Short-circuit proof

Characteristic of electrical components. A short-circuit proof part withstands thermal and dynamic loads which can occur at its place of installation due to a short circuit.

Station

A functional unit or I/O components consisting of a number of elements.

T

TCP

Abbreviation for Transmission Control Protocol, connection-oriented transport protocol within the Internet protocol suite. Certain error detection mechanisms (i.e. acknowledgements, time-out monitoring) can guarantee a safe and error free data transport.

Terminating resistance

Resistor on both ends of a bus cable used to prevent interfering signal reflections and which provides bus cable matching. Terminating resistors must always be the last component at the end of a bus segment.

To ground

Connection of a conductive component with the grounding connection via a grounding installation.

Topology

Geometrical structure of a network or the circuitry arrangement.

U

UDP

Abbreviation for User Datagram Protocol. UDP is an transport protocol for the connectionless data between Ethernet hosts.

Unidirectional

Working in one direction.

15 Index

- A**
- acyclic services 8-14
 - Address assignment 3-15
 - address assignment 8-2
 - auxiliary power supply 3-9
- B**
- Base modules 2-7
 - basic concept 2-2
 - BL20 components 2-3
 - block diagram, station 11-4
- C**
- Cable routing 11-2
 - cable shield 11-7
 - classes
 - Assembly Object 4-6
 - Connection Manager Object 4-9
 - Ethernet Link Object 4-14
 - Ethernet/IP standard 4-3
 - Identity Object 4-4
 - process data 4-20
 - TCP/IP Interface Object 4-10
 - VSC-Vendor Specific Classes 4-16
 - CoDeSys 7-2
 - communication path 7-8
 - communication settings 7-7
 - Ethernet-master 7-9
 - feature sets 7-4
 - Global variable list 7-14
 - localhost 7-7
 - Modbus TCP-master 7-10
 - Net work configuration 7-3
 - PLC_PRG 7-13
 - C-rail (cross connection) 10-7
- D**
- DHCP mode 13-22
 - Diagnosis 9-18, 9-19
 - diagnosis 8-4
 - Diagnostic messages, modules 3-56
 - Division 2 12-1
- E**
- earth-free operation 11-5
 - electrical installation 11-2
 - electrostatic discharge 11-8
 - EMC 11-5
 - End bracket 2-8
 - End plate 2-8
 - error code 9-19
 - error codes
 - gateway 8-4
 - I/O-modules 8-5
- F**
- firmware download 10-11
 - Flexibility 2-2
- G**
- Gateway
 - block diagram 3-7
 - parameters 8-10
 - gateway
 - address assignment 3-15, 8-2
 - function 3-3
 - LEDs 3-12
 - PGM-mode 3-21
 - service-interface 3-14
 - technical data 3-6
 - Gateway, parameters 8-10
- H**
- handling 2-2
 - Hardware 5-2, 7-2
- I**
- inductive loads, protective circuit 11-8
 - IP address, PC 13-16
- L**
- lightning protection 11-3
- M**
- maintenance 1-4
 - Modbus TCP
 - register 6-4
 - Module Application Instance 8-15
 - module arrangement 10-2
 - module diagnostics , channel specific 9-18, 9-19
 - module order 10-2
 - mounting rail 11-6
- N**
- Network configuration 5-1
- O**
- operation, safe 1-4
 - operation, trouble-free 1-4
 - outputs, error behavior 6-23
- P**
- PE connection 11-5
 - potential compensation 11-8
 - potential compensation cable 11-8
 - potential groups 10-7
 - potential relationships 11-4
 - prescribed use 1-4
 - process data 4-8
 - Process input
 - RSxxx 13-2

Index

–SWIRE	13-13
process input	
–SSI	13-6
Process out	
–SWIRE	13-14
Process output	
–RSxxx	13-4
process output	
–SSI	13-11
product overview	2-1

S

shield	11-7
Software	5-2, 7-2
storage	1-4
supply voltage	3-9, 3-14
Symbols	1-3
symbols	1-3

T

Terminal Slot Class	4-18
transmission media	11-3
transport	1-4
transport, appropriate	1-4

U

use, prescribed	1-4
user data	8-14

W

WIN 2000	13-16
WIN NT	13-16
WIN XP	13-16

Z

Zone 2	12-1
--------------	------

TURCK

Industrial
Automation



www.turck.com

Hans Turck GmbH & Co. KG
45472 Mülheim an der Ruhr
Germany
Witzlebenstraße 7
Tel. +49 (0) 208 4952-0
Fax +49 (0) 208 4952-264
E-Mail more@turck.com
Internet www.turck.com

D301173 0713