

RMS and peak acceleration loop powered sensors

PC420A series



Wilcoxon’s 4-20 mA vibration sensors integrate easily with an existing PLC, DCS or SCADA system. The PC420A series provides 24/7 output of overall machine vibration for trending in PLC systems, alerting users to changing machine conditions and helping to guide maintenance in prioritizing the need for service. The choice of RMS or peak output allows you to choose the sensor that best fits your industrial requirements.

The 4-20 mA output of the PC420A series is proportional to acceleration vibration. An output of 4 mA indicates a level of 0 g or no vibration present. A full-scale reading of 20 mA indicates that the maximum range (RMS or peak) of vibration is present.

Key features

- Choice of true RMS or calculated peak output
- Corrosion resistant
- Hermetically sealed
- ESD protection
- Overload protection
- Reverse wiring protection

Certifications

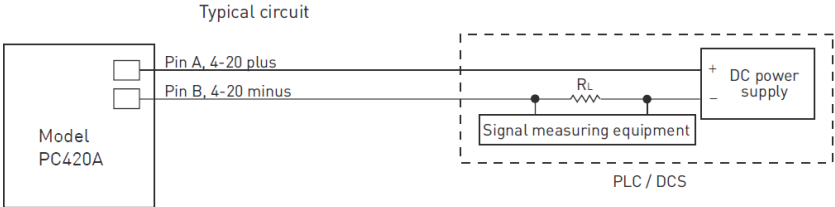

Connections	
Function	Connector pin
ground	shell
loop positive (+)	A
loop negative (-)	B

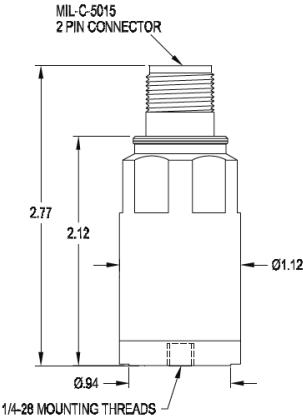

Note: Due to continuous process improvement, specifications are subject to change without notice. This document is cleared for public release.

RMS and peak acceleration loop powered sensors

PC420A series

SPECIFICATIONS

OUTPUT, 4-20 mA	
Full scale 20 mA, $\pm 5\%$	see table 1
Frequency response:	
$\pm 10\%$	10 Hz - 1 kHz
± 3 dB	1 Hz - 2 kHz
Repeatability	$\pm 2\%$
Transverse sensitivity, max	5%
Power requirements (two-wire loop power):	
Voltage at sensor terminals	12 - 30 VDC
Loop resistance at 24 VDC, max	700 Ω
Turn on time, 4-20 mA loop	< 30 seconds
Grounding	case isolated, internally shielded
Operating temperature range ¹	-40 to +105° C
Vibration limit	250 g peak
Shock limit	2,500 g peak
Sealing	hermetic
Sensing element design	PZT, shear
Weight	160 grams
Case material	stainless steel
Mounting	1/4-28 tapped hole
Output connector	2-pin, MIL-C-5015 style
Mating connector	R6 type
Recommended cabling	J9T2A

Table 1: PC420Ax-yy model selection

x (4-20 mA output type)	yy (4-20 mA full scale)
R = RMS output, acceleration	05 = 5 g
P = Calculated peak output, acceleration	10 = 10 g
	20 = 20 g
	50 = 50 g

DC supply voltage	R _L (max resistance) ²	R _L (minimum wattage capability) ³
12 VDC	100 Ω	1/8 watt
20 VDC	500 Ω	1/4 watt
24 VDC	700 Ω	1/2 watt
26 VDC	800 Ω	1/2 watt
30 VDC	1,000 Ω	1/2 watt

Note: Due to continuous process improvement, specifications are subject to change without notice. This document is cleared for public release.

Wilcoxon Sensing Technologies
20511 Seneca Meadows Parkway
Germantown, MD 20876
info@wilcoxon.com

Tel: (301) 330 8811
Fax: (301) 330 8873
www.wilcoxon.com

Contact

Wilcoxon Sensing Technologies

20511 Seneca Meadows Parkway
Germantown MD 20876, USA

Tel: +1 301 330 8811
Fax: +1 301 330 8873

info@wilcoxon.com

www.wilcoxon.com

Accessories supplied:

- SF6 mounting stud (metric mounting available)
- Calibration data (level 2)

Notes: ¹ Maximum loop resistance (R_L) can be calculated by:

$$R_L = \frac{VDC - 10 V}{20 \text{ mA}}$$

² Lower resistance is allowed, greater than 10 Ω recommended.

³ Minimum R_L wattage determined by: (0.0004 x R_L).