

MODEL 510RM 5 VALVE MANIFOLD, REMOTELY MOUNTED

- Pressures up to 6000psi
- Standard 2.13" center to center inlet/outlet
- 3/16" bore
- Wide choice of materials and options

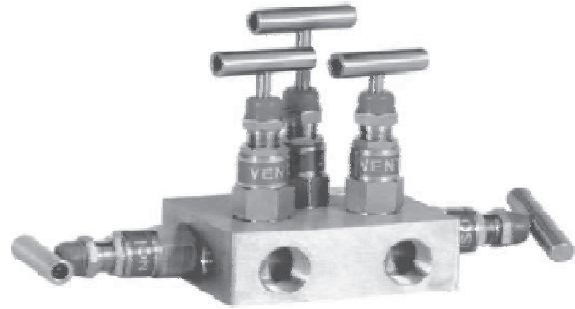

Introduction

Model 510 Remotely Mounted 5 valve manifold allows manifold to be remote from the differential gauge, switch or transmitter. Two isolating and one equalising valve are provided in a single compact space saving unit.

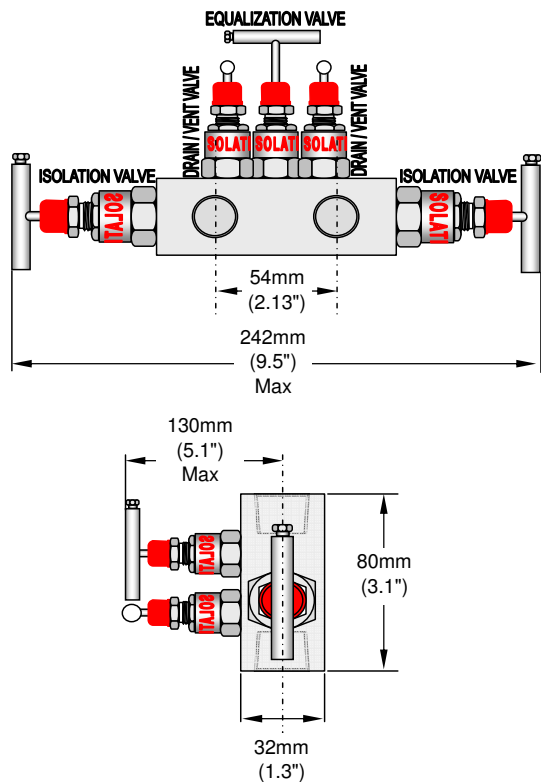
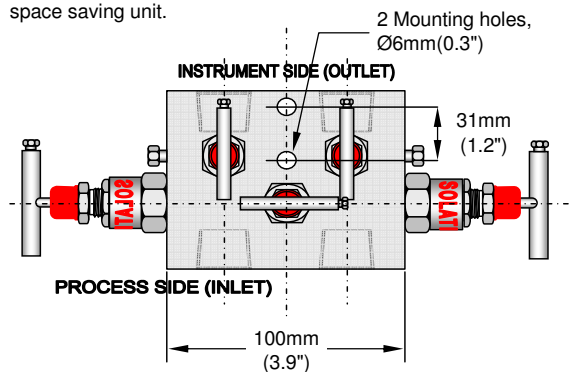

Specifications

Material of Construction:

SS316, Monel, Hastelloy

Test Pressure (at 25°C Room Temperature)

Hydrostatic:	Body	-	620Bar
	Seat	-	415Bar
Pneumatic:	Seat	-	40Bar

Gland Packing

PTFE	:	Standard
Graphoil	:	Temperatures Above 180°C

Finish

Natural

Connection:

Inlet	Outlet	Drain/Vent
See Below	See Below	1/4" NPT(F)

Mounting Kit

Mounting Bracket with "U" Bolts and Necessary kits for fitting on 2" NB Stanchion pipe stand or wall mount. (Order Separately)

Weight

6.83LBS (3.1Kg)

Accessories

Mounting Bolts, Teflon Rings

Order Information

Model	Description		
510RM	5 Valve Manifold, Remote Mounted		
	Code	Inlet	Outlet
	01	1/4" NPT (F)	1/4" NPT (F)
	02	3/8" NPT (F)	3/8" NPT (F)
	03	1/2" NPT (F)	1/2" NPT (F)
	Code	Materials of Construction	
	S2	SS 316	
	CS	Carbon Steel	
	MN	Monel 400	
	HA	Hastelloy C	
	XX	Other (Specify)	
		Code	Packing Material
		TF	Teflon
		GR	Graphoil
		XX	Other (Specify)
510RM	03	S2	TF