

## 3115F-12390

## STRAIN GAUGE CYLINDER (TESTING HARDENED CONCRETE)

Standard reference force transducer specially designed for checking concrete testing machines according to the norms EN 12390-4 and DIN 51302-2

Model 3115F-12390



### Features

- Allows checking the homogeneity of the repartition of the forces generated by verifying:
  - o self-alignment and restraint on movement of the upper platen
  - o alignment of the component parts of the machine
- Normalized dimensions
- 4 independent full bridges @ 90
- Protection: IP65
- Material: Nickel plated alloy steel
- Cable length : 4x6m
- Options :
  - o digital output USB, RS-485 or RS-232C
  - o class 1 and 05 following ISO376
  - o ASTM E74 compliant

### Applications

The SENSY's load cell 3115F-12390 is perfectly designed to the following applications :

Testing Machines for measure of compressive strength of hardened concrete according to EN 12390

### Capacities

3115F-12390 : 2 MN

### Specifications

	1	
Accuracy class	"1"	-
Relative reversibility error	<± 0.3	% R.O.
Relative repeatability error with rotation	<± 0.2	% R.O.
Relative repeatability error without rotation	<± 0.1	% R.O.
Time of stabilization after power excitation suppl	200... 600	s
Creep error over 30 min.	<± 0.1	% F.S.
Zero shift after loading	<± 0.05	% F.S.
Reference temperature	20	C
Nominal temperature range	-10...+45	C
Service temperature range	-30...+70	C
Storage temperature range	-50...+85	C
Temperature coefficient of the sensitivity	< ± 0.035	% F.S./10 C
Temperature coefficient of zero signal	< ± 0.03	% F.S./10 C
Zero balance	± 0.02	mVV
Insulation resistance (50V)	> 5000	Megaohm
Reference excitation voltage	10	VDC
Nominal range of excitation voltage	3..12	VDC
Nominal sensitivity	1.5	mVV
Safe load limit	110	% F.S.
Breaking load	>300	% F.S.
Input resistance	350..702 ± 2	Ohm
Output resistance	350..702 ± 2	Ohm

- RO is the rated output (i.e.: measured value). The mentioned values are only valid if RO >= 20% of full scale).

- FS is the full scale of the force transducer.

- Specifications subject to change without notice.

# LOAD CELLS

modele 3115F stainless steel

## COMPRESSION

Spécial sensor following EN 12390-4 & DIN 51302-2  
( 4 independents full bridges )

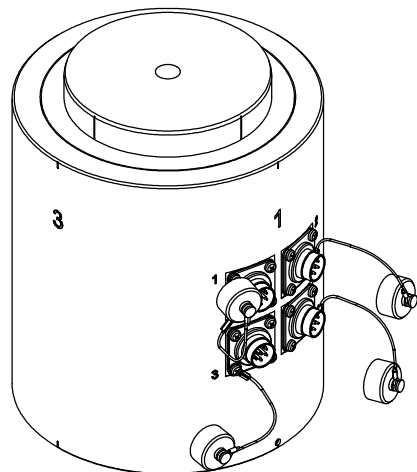
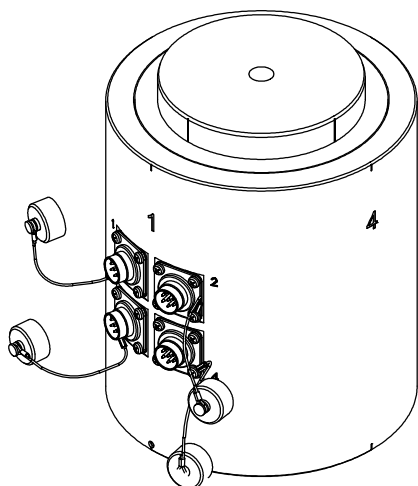
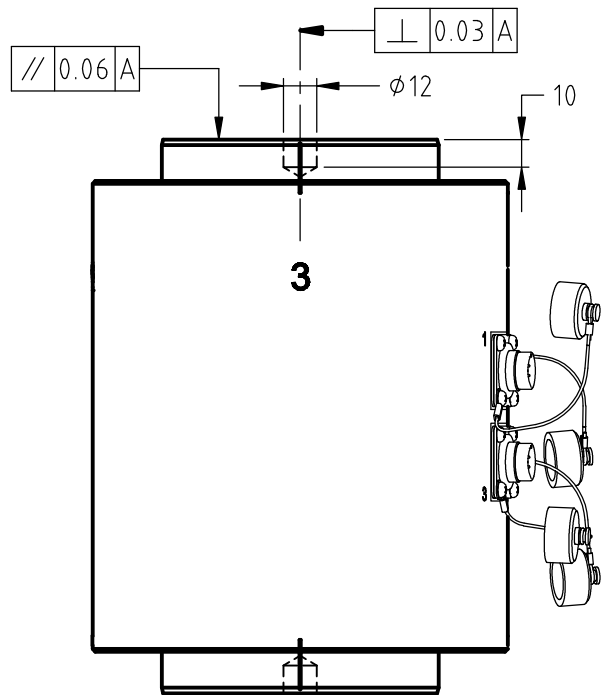
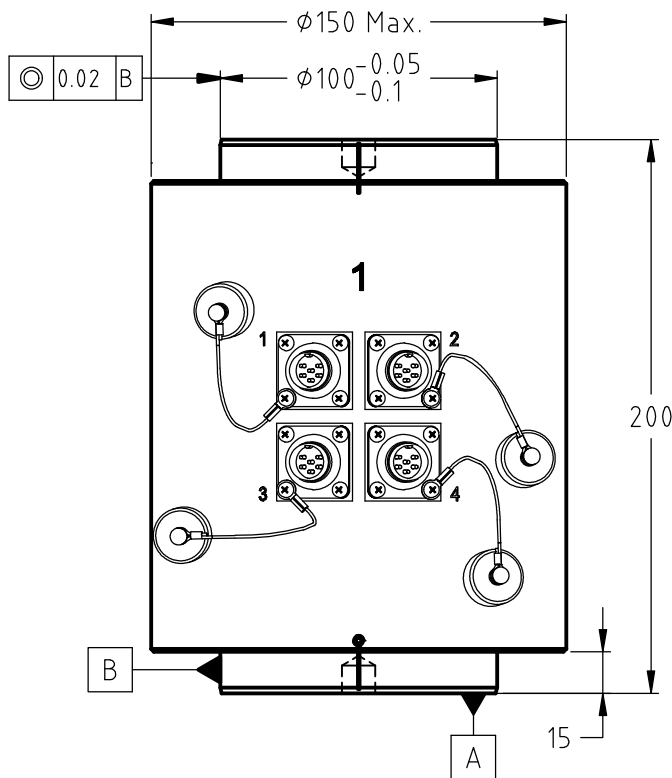

FEMALE-MALE CONNECTOR DIN 45322

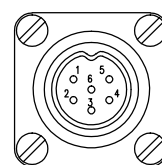

CONTACT N°		
1	Excitation	- Yellow
2	Signal	+ Green
3	Signal	- White
4	Excitation	+ Brown
5	Sense	- Grey
6	Sense	+ Pink

Cable screen not connected to transducer  
Option f : Cable screen connected to transducer