

2712-ISO

STANDARD REFERENCE FORCE TRANSDUCER TENSION AND COMPRESSION

Standard reference force transducer specially designed according to the norm ISO 376(1) (Class "1", "05" and "00").

Model 2712 - 50 daN



Features

- Broad range of capacities
- Tension and compression
- Compact design
- Overload protection : See drawing's table)
- Complete range of load accessories
- Protection : See drawing's table (IP)
- Material : Aluminium
- Cable length : 3m
- Options :
 - o digital output signal (RS-232C, RS-485, USB)
 - o ASTM E74 compliant

Applications

The SENSY's load cell 2712-ISO is perfectly designed to the following applications :

- Control of testing machines according to ISO7500

Note : This standard covers the calibration of standard force measurement instruments used for the static verification of uniaxial testing machines. it describes classifying procedures for the instruments.

Capacities

2712 : 0,2 - 0,5 - 1 - 2 - 5 and 10 kN

Specifications	1	05	00	
Accuracy class	"1"	"05"	"00"	-
Relative reversibility error	<± 0.3	<± 0.15	<± 0.07	% R.O.
Relative repeatability error with rotation	<± 0.2	<± 0.1	<± 0.05	% R.O.
Relative repeatability error without rotation	<± 0.1	<± 0.05	<± 0.025	% R.O.
Time of stabilization after power excitation suppl	200... 600	200... 600	200... 600	s
Creep error over 30 min.	<± 0.1	<± 0.05	<± 0.025	% F.S.
Zero shift after loading	<± 0.05	<± 0.025	<± 0.012	% F.S.
Reference temperature	20	20	20	C
Nominal temperature range	-10...+45	-10...+45	-10...+45	C
Service temperature range	-30...+70	-30...+70	-30...+70	C
Storage temperature range	-50...+85	-50...+85	-50...+85	C
Temperature coefficient of the sensitivity	< ± 0.035	< ± 0.035	< ± 0.015	% F.S./10 C
Temperature coefficient of zero signal	< ± 0.03	< ± 0.03	< ± 0.023	% F.S./10 C
Zero balance	± 0.02	± 0.02	± 0.02	mV/V
Input resistance	352 ± 2	352 ± 2	352 ± 2	Ohm
Output resistance	352 ± 2	352 ± 2	352 ± 2	Ohm
Insulation resistance (50V)	> 5000	> 5000	> 5000	Megaohm
Reference excitation voltage	10	10	10	VDC
Nominal range of excitation voltage	3..12	3..12	3..12	VDC
Nominal sensitivity	2	2	2	mV/V
Safe load limit	110	110	110	% F.S.
Breaking load	>300	>300	>300	% F.S.

- RO is the rated output (i.e.: measured value). The mentioned values are only valid if RO >= 20% of full scale).

- FS is the full scale of the force transducer.

- Specifications subject to change without notice.

LOAD CELL

model 2712 aluminium

TENSION-COMPRESSION



Range 200 N - 10 kN

Protection see table (IP)
Cable length : 3 m

Integrated overload protection 200 N - 3 kN

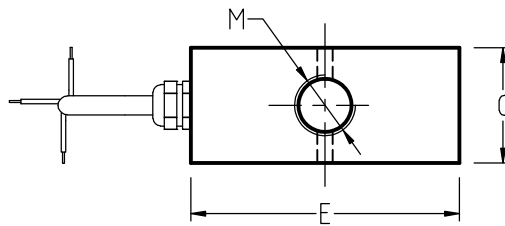
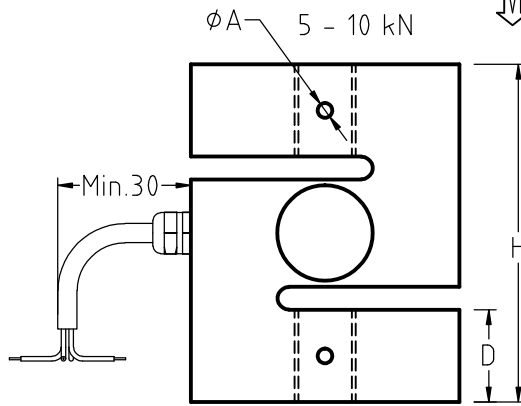
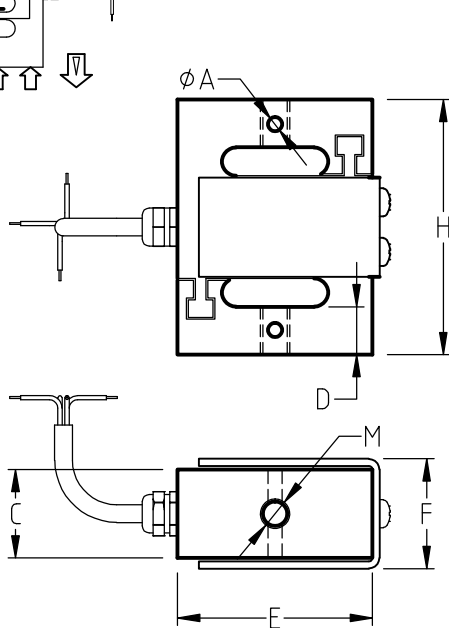
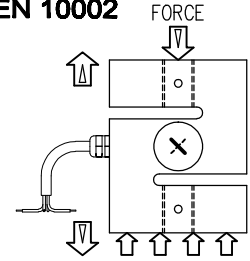
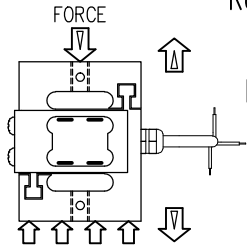

CAPACITIES	φA	H	C	D	E	F	M	H1	H2	Breaking	Max.deflexion	IP	Weight
200 - 1000 N	4	72	25	13.5	55	±32	M8	132	167	1000 %	0.40 mm	IP 54	0.42 kg
1.5 - 3 kN							M12			600 % Max.20 kN	0.35 mm	IP 65	
5 - 10 kN		88	30	24	70	/	M16	188	233	-----	0.30 mm	IP 65	0.6 kg

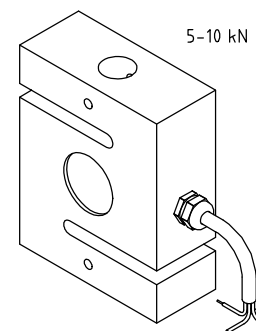
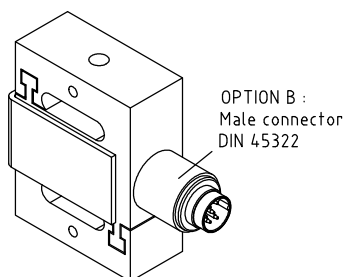
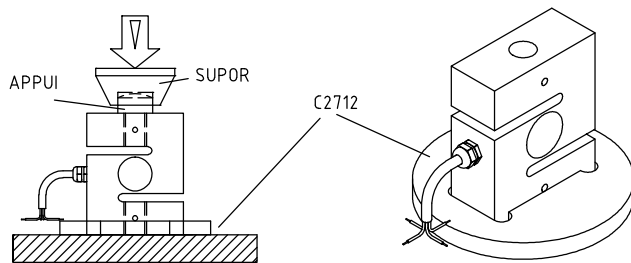
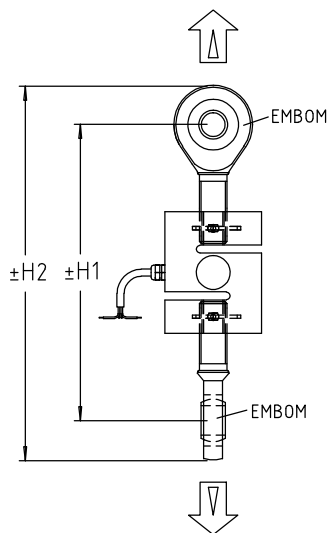

Note: Standard wiring for compression



ACCESSORIES

model C2712 aluminium

CENTERING PIECE FOR LOAD CELLS 2712 and 2715

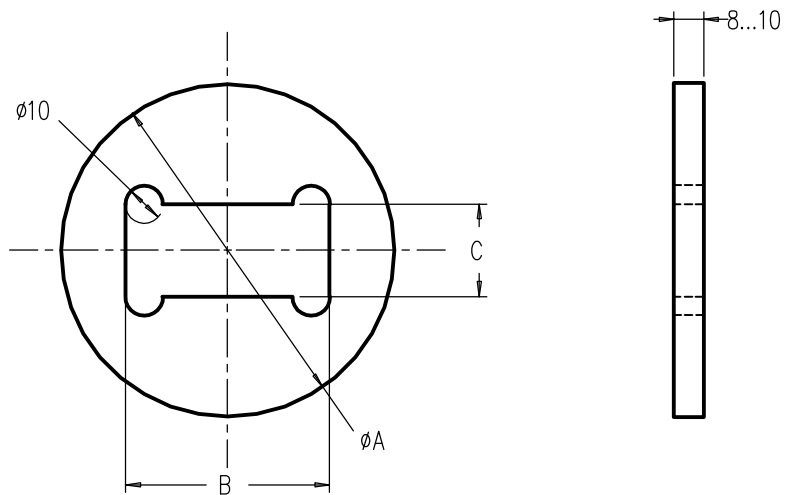

CAPACITIES	ϕA	B	C	For load cell
10	89	55	25	2712 10 - 500 daN
750	109	70	30	2712 750 - 1000 daN
20 kN	139	98	38	2715 20 - 50 kN
75 kN	179	118	56	2715 75 -100 kN
150 kN	199	146	67	2715 150 - 200 kN

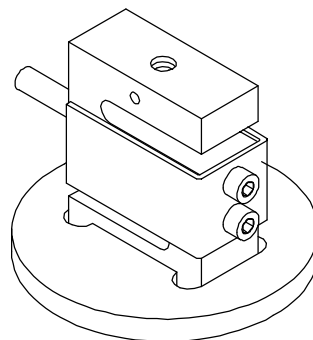
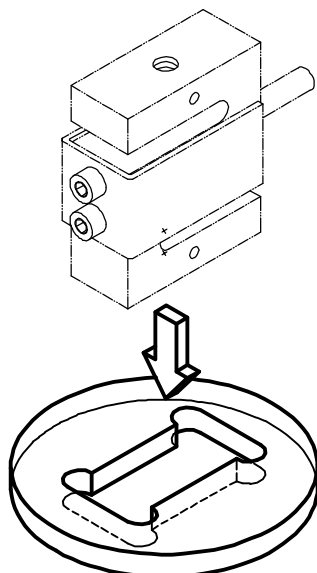

CHOICE OF THE LOADING PADS FOR MODEL 2712(5)



(EN 10002-3 & DIN 51301)

Principles: according to ISO 376.
The pressure on the compression plates of the testing machine should not be higher than 100 N/mm².

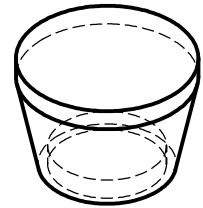
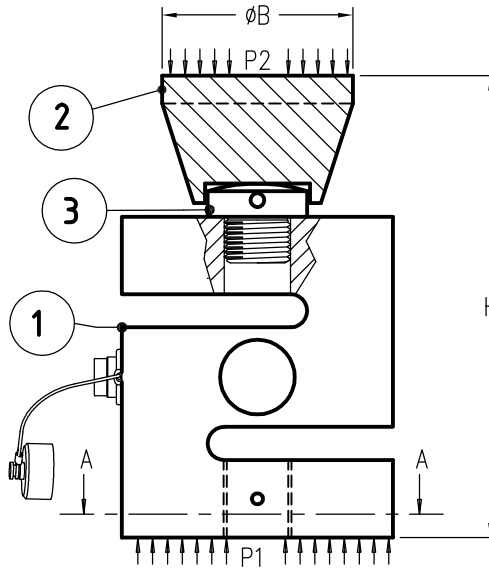
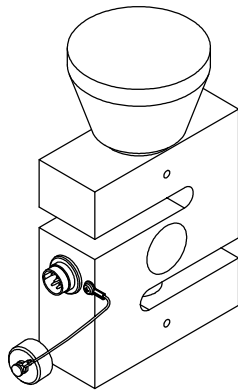

SUPOR



APPUI

SECTION A-A

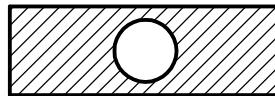

MODEL	CAPACITY ①	Section A-A mm ²	Pressure P1 N/mm ²	TYPE ②	φB	Section φB mm ²	Pressure P2 N/mm ²	TYPE ③	H
2712	10 daN	1325	0.1	SUPOR 20	49	1886	0.1	APPUI 8	105
	15 daN		0.1				0.1		
	20 daN		0.2				0.1		
	30 daN		0.2				0.2		
	50 daN		0.4				0.3		
	75 daN		0.6				0.4		
	100 daN		0.8				0.5		
	150 daN		1.1				0.8		
2712	200 daN	1262	1.6	SUPOR 20	49	1886	1.1	APPUI 12	108
	300 daN		2.4				1.6		
	500 daN		4				2.7		
2712	750 daN	1703	4.4	SUPOR 30	64	3217	2.3	APPUI 16	135
	1000 daN		5.9				3.1		
2715	20 kN	3272	6.1	SUPOR 36	69	3739	5.3	APPUI 24	167
	30 kN		9.2				8		
	50 kN		15.3				13.4		
2715	75 kN	5590	13.4	SUPOR 56	79	4902	15.3	APPUI 36	190
	100 kN		19.9				20.4		
2715	150 kN	8192	18.3	SUPOR 64	99	7698	19.5	APPUI 45	222
	200 kN		24.4				26		